

**DYNAMIC ANTISYMMETRY AND THE SYNTAX
OF NOUN INCORPORATION**

by

Michael Jonathan Mathew Barrie

A thesis submitted in conformity with the requirements

for the degree of Doctor of Philosophy

Graduate Department of Linguistics

University of Toronto

© Copyright by Michael Jonathan Mathew Barrie (2006)

Abstract

Dynamic Antisymmetry and the Syntax of Noun Incorporation

Doctor of Philosophy, 2006

Michael Jonathan Mathew Barrie

Department of Linguistics, University of Toronto

This thesis is concerned with how syntactic structures are mapped into a linear order. As a starting point, I consider the initial merger of two heads, a and b , which forms the unordered set $\{\gamma, \{a, b\}\}$, where γ is the label of the set. The two heads, a and b c-command each other, in violation of Kayne's Linear Correspondence Axiom. Adopting Moro's Dynamic Antisymmetry, I propose that the non-projecting head moves to the specifier of the projecting head to eliminate symmetric c-command and establish linear order. This process triggers successive compl-to-spec movement until a phonologically empty head is merged into the derivation. Since phonologically empty elements do not need to be linearized, compl-to-spec movement is not required to break symmetric c-command. This process is the theoretical kernel of this thesis – that phrase structure is sensitive to the needs of PF, namely, the need to attain linear order, and that phrase structure is manipulated early in the derivation to achieve linear order.

Empirically, this thesis is concerned with noun incorporation principally in Oneida (Iroquoian), but other languages are considered. It recognizes the robust cross-linguistic generalization for noun incorporation constructions to form N+V sequences, while non-incorporated constructions exhibit V+DP sequences (SOV languages aside, whose word order properties reduce to factors extraneous to those considered here). This thesis puts forth the proposal that noun incorporation arises by the need for grammar to

be able to linearize the derivation. Thus, when a verb merges with a bare noun the {V, N} set is symmetric, thus non-linearizable. This symmetry forces compl-to-spec raising, giving rise to the observed N + V order. When the verb merges with a full DP, the verb asymmetrically c-commands material inside the DP, thus no compl-to-spec movement is required here. The empirical kernel of this thesis then is a Dynamic Antisymmetric treatment of the syntax of noun incorporation in which the cross-linguistically robust N + V sequence falls out as a consequence of the attempt on the part of phrase structure to achieve linearity.

Acknowledgements

First and foremost, I wish to thank my consultants, without whom this endeavour would of course be impossible. These are Daisy Elijah (Oneida), Nora Carrier and Gloria Williams (Onondaga), Jila Ghomeshi (Persian), Gabriela Alboiu and Monica Irimia (Romanian) and Bettina Spreng (German). I would also like to thank Ulyana Savchenko and Tanya Slavin for their help with the Russian data. Without the tireless efforts of our valuable consultants, our world would be a much different place than it is today.

I first arrived at the Department of Linguistics at the University of Toronto daunted, a little unsure, and extremely excited – Daunted at the caliber of the faculty and students, a little unsure of how I would not only fare, but fit in, and extremely excited to be in such an inviting and vibrant community of linguists. Four other graduate students in particular, probably completely without knowing it, shaped my expectations of myself as a Ph.D. student of linguistics when I arrived: Milan Rezac, Susana Béjar, Arsalan Kahnemuyipour and Bettina Spreng. The level of productivity and caliber of work that Milan, Susana, Arsalan and Bettina produced allowed me to set high expectations for myself, which I hope I have lived up to.

Thanks to Kenji Oda, Richard Compton, Christine Pittman, Sara Mackenzie, Bettina Spreng, Arsalan Kahnemuyipour and everyone else who accompanied me on my coffee breaks at times when I simply needed to take a break, but didn't want to go by myself. Special thanks go to Magdalena Goledzinowska for accompanying me all the way into Kensington market for coffee, just because I wanted to get out of the department (and eat pastry). Those of you who know me, know how important coffee (and pastry) is to me, and thus many thanks are deserved!

A tremendous thank-you is owed to the entire faculty in the Department of Linguistics for their kindness and support during my studies here. Elizabeth Cowper's extremely keen eye never missed the tiniest flaw in reasoning in my work. Her abilities in linguistics are matched only by her editorial and leadership skills. If it were not for her constant revisions on this dissertation, it would most likely be still unreadable. Thanks to Diane Massam, Alana Johns, Yves Roberge and Gabriela Alboiu for agreeing to serve on my thesis committee and for their valuable input. Additional thanks to Gabriela for all of our collaborative work, which has been most rewarding for me. Thanks also go to Elan Drescher and Keren Rice for continuing to nurture the latent phonologist in me. I would also like to thank Andrea Moro for agreeing to read my thesis and for his helpful comments and suggestions.

Finally, I would like to thank my family for their unwavering support throughout this phase in my life. William Seto has been more than patient and understanding on many a night when he was finished work, and I'd still be at my computer finishing off some revisions, or preparing for yet another conference. Without his tireless support, this endeavour would surely have been impossible. Another round of thanks goes to Will for introducing me to Cantonese and Chinese culture. Thanks, of course, go to my parents for not holding me back when I switched from an undergrad in Molecular Biology and Genetics to graduate program in some discipline they had never heard of...and for not holding me back in life when I needed to discover the world for myself.

Table of Contents:

ABSTRACT	II
ACKNOWLEDGEMENTS.....	IV
LIST OF ABBREVIATIONS.....	VIII
1. INTRODUCTION	1
1.1. Background.....	1
1.1.1. Phrase Structure Rules	7
1.1.2. X-Bar Theory.....	10
1.1.3. The Headedness Parameter.....	10
1.2. Theoretical Assumptions	15
1.2.1. Bare Phrase Structure.....	15
1.2.2. Adjunction.....	17
1.2.3. Move.....	21
1.2.4. Antisymmetry	24
1.2.5. Head Movement.....	29
1.2.6. Invasive Interfaces	38
1.3. Alternative Accounts of Linearization.....	38
1.3.1. Fukui and Takano (1998).....	39
1.3.2. Oishi (2003).....	40
1.3.3. Nakajima (1999).....	43
1.3.4. Conclusion	44
1.4. Conclusion	45
2. UNIFYING ANTISYMMETRY AND BARE PHRASE STRUCTURE	46
2.1. Previous Accounts	47
2.1.1. Guimarães (2000).....	48
2.1.2. Nunes and Uriagereka (2000).....	53
2.1.3. Richards (2001).....	53
2.1.4. Conclusion	54
2.2. The LCA and Bare Phrase Structure.....	55
2.2.1. Object Shift and Extraction.....	67
2.2.2. Super C-Command.....	72
2.3. The Problem of Mutual C-command	86
2.4. Proposal.....	87
2.5. Alternatives to Compl-to-spec Roll-up.....	94
2.5.1. Spec-to-Spec Movement and Romance Clitics.....	95
2.5.2. Avoidance of the Initial Merger Problem.....	99
2.6. Linearization and Late Insertion	104
2.7. Summary	106
3. ONEIDA NOUN INCORPORATION	108
3.1. Oneida Clause Structure	108
3.2. Patterns of Noun Incorporation in Oneida.....	114
3.2.1. Verbal Roots	115
3.2.1.1. Obligatory Incorporation	115
3.2.1.2. Optional Incorporation.....	120
3.2.1.3. Non-incorporating Verbal Roots.....	121

3.2.2.	Nominal Roots	123
3.3.	Analysis.....	126
3.3.1.	Previous Analyses.....	126
3.3.2.	Noun Incorporation as Phrasal Movement	131
3.3.2.1.	The Incorporation of Deverbal Nouns	131
3.3.2.2.	The Incorporation of Nominal Roots.....	135
3.4.	Iroquoian DPs	140
3.5.	Properties of Iroquoian Noun Incorporation.....	142
3.5.1.	Noun Incorporation in Ditransitives	143
3.5.2.	Noun Incorporation and Overt DPs	145
3.6.	Conclusion	148
4.	NOUN INCORPORATION AND ITS KIND IN OTHER LANGUAGES.....	150
4.1.	Patterns of English Gerunds.....	150
4.2.	Analysis.....	153
4.3.	Incorporation into Gerunds and Progressives in Other Languages	156
4.3.1.	German Progressives	156
4.3.2.	Persian “Long Infinitive” Constructions.....	162
4.4.	Tamil Noun Incorporation and Coordination	166
4.5.	Conclusion	170
5.	PSEUDO NOUN INCORPORATION	172
5.1.	Polynesian Pseudo Noun Incorporation.....	173
5.1.1.	The Structure of Niuean Nominals	174
5.1.2.	Pseudo Noun Incorporation	178
6.	CONCLUSION.....	181
6.1.	Summary	181
6.2.	Conclusions and Implications	182
	REFERENCES	188

List of Abbreviations

ABS	absolute
ACC	accusative
BEA	Beyond Explanatory Adequacy
C	common noun
CL	clitic
CONT	continuous
DEM	demonstrative
DU	dual
DUAL	dualic
EPEN	epenthetic
ERG	ergative
EXCL	exclusive
EZ	ezafe vowel
FACT	factual
F	feminine
FUT	future
GB	Government and Binding
GEN	genitive
HAB	habitual
INCL	inclusive
INF	infinitive
INSTR	instrumental
JOIN	joiner vowel – see footnote 112 and accompanying text
LCA	Linear Correspondence Axiom
M	masculine
N/F	neuter/feminine – see footnote 102.
NOM	nominative
NFS	noun forming suffix
NT	neuter
NZLR	nominalizer
OBL.CL	object clitic pronoun
P	proper noun
PL	plural
PRF	perfect
PRFV	perfective
PUNC	punctual
REFL	reflexive
SG	singular
SRFL	semi-reflexive
STAT	stative
T	set of terminal nodes (used in definitions related to Antisymmetry)
TNS	tense

1. Introduction

1.1. Background

Phrase structure has occupied a central role in grammar since Chomsky (1957), where it is first proposed that such a level is required in any adequate theory of generative grammar in order to capture the hierarchical properties of language. That language is organized hierarchically rather than linearly is demonstrated by the following examples.

- (1) a. Is_i the girl who was petting the cat *t_i* named Rosie?
b. *Was_i the girl who *t_i* petting the cat is named Rosie?
- (2) *Placement of Possessive morphology in English*
 - a. John's hat
 - b. The man I saw yesterday's hat
 - c. * The man's I saw yesterday hat

In example (1), the auxiliary *is* moves to the front of the sentence as shown, even though the auxiliary *was* is closer to the beginning of the sentence in a linear sense. In other words, the auxiliary that does move is closer hierarchically, but not linearly. Thus, a purely linear approach to explaining which auxiliary moves in yes/no questions is inadequate, and a phrase-structural account must be pursued. In example (2), we see that the genitive marker 's is not simply placed after the first word, but after some hierarchically determined unit – namely, the DP possessor.

Since 1957, many advances have been made in how we can best understand syntactic hierarchy and phrase structure, some of which I review here. This thesis examines two recent, well-received proposals about phrase structure and melds them into

a single cohesive framework. Specifically, I examine Bare Phrase Structure (BPS) (Chomsky, 1994) and Antisymmetry (Kayne, 1994) and propose that the insights of both proposals can be maintained. In doing so, I also consider other recent proposals on this topic. The core of the proposal is that Antisymmetry and Bare Phrase Structure can both be retained if we adopt a Dynamic Antisymmetric view as proposed by Moro (2000; 2004). Moro proposes that movement is driven by the need for the computational component to satisfy the LCA. Thus, if two terms cannot be linearized because they do not satisfy the Linear Correspondence Axiom (LCA) of Kayne (1994), something must move so that the LCA is satisfied. In particular, I examine the case of two symmetrically c-commanding heads; a situation that arises upon the initial merger of two heads (the Initial Merger Problem). What I propose here is the following: not only does an LCA violation (in particular, symmetric c-command) trigger movement, it triggers a cascade of movements, which I call Compl-to-spec roll-up. (This type of movement has, of course, been seen elsewhere in the literature, sometimes under a different name, and with a different motivation.¹) Furthermore, only an empty category can halt Compl-to-spec roll-up. In this dissertation, I will be concerned mostly with heads and whether they are phonologically specified or empty.

The empirical foundation for this study consists of noun incorporation and related phenomena. As far as I know, noun incorporation has not been given a thorough Antisymmetry treatment. I believe, however, that the data provide crucial evidence for the core proposal put forth here: that symmetric c-command between two phonologically specified heads triggers movement and that a phonologically null head stops movement.

¹ These will come up later in the discussion where appropriate. Representative examples include *snowballing* (Aboh, 2004a) and *intraposition movement* (Rackowski and Travis, 2000).

In particular, this proposal captures the fact that a full DP complement to a verb and a bare noun complement to a verb often exhibit different linearization properties.² This asymmetry is exhibited by the noun incorporation data, which will be presented in fuller detail in Chapters 3, 4 and 5. In the following examples, the verbs are shown in **boldface** and the complement nouns are *italicized* to show their relative positions. The (a) examples contain full DP complements and the (b) examples contain noun complements that have undergone noun incorporation.

(3) *Noun Incorporation in Oneida* [Daisy Elijah, speaker]

a. waʔ**khni:nú:** *ká:sleht*

waʔ-	k-	hniu-	´:	ka-	ʔsleht-	Ø
FACT-	1.SG.NOM-	buy-	PUNC	3.SG.NT-	car-	NFS

‘I bought a car.’

b. waʔkeʔ*sleht***hni:nú:**

waʔ-	k-	e-	ʔsleht-	a-	hniu-	´:
FACT-	1.SG.NOM-	EPEN-	car-	JOIN-	buy-	PUNC

‘I bought a car.’

(4) *noun incorporation in English Gerunds*

a. Alice enjoys **collecting** *stamps*.

b. Alice enjoys *stamp*-**collecting**.

(5) *German Progressives*^{3,4}

a. Ich	esse	<i>die</i>	<i>Äpfel</i> .
I	eat.1.SG	the	apple.PL

‘I’m eating the apples.’

² Throughout this thesis, I use the term *bare noun* to mean functionally bare, rather than morphologically bare in the sense of Giorgi and Longobardi (1991).

³ Of course OV word order is possible with full DP objects, as German is an SOV language. The point here is that full DP objects can appear in either VO or OV word order, depending on whether the verb appears in 2nd position or sentence-finally. With bare nominal objects as in the progressive *beim* construction, only OV word order is found.

⁴ Unless otherwise stated, all German data are from Bettina Spreng.

- a. Ich bin beim *Äpfel-* **essen.**
 I am at.the apple.PL- eat.INF
 ‘I’m eating apples.’ / ‘I’m busy apple-eating.’

(6) *Persian Long Infinitives*⁵

- a. sima æz **xundæn-e** *in ketab* xoš-eš mi-yad
 Sima from reading-EZ this book good-3SG.CL CONT-come.3SG
 ‘Sima likes reading this book.’
- b. sima æz *ketab* **xundæn** xoš-eš mi-yad
 Sima from book reading good-3SG.CL CONT-come.3SG
 ‘Sima likes reading books.’

In English, for example, full DP complements appear to the right of the verb, and what is arguably a bare noun appears to the left of the verb. Gerunds are taken up in more detail in chapter 4. These data show an important asymmetry between full DP objects and bare noun objects. Specifically, whether the object appears before or after the verb depends on whether the object is a full DP or bare noun. Of course, other factors may affect VO versus OV word order (see footnote 3), but the generalization still holds. The theory of phrase structure that I propose here accounts for this asymmetry in a straightforward way.

The proposal in a nutshell goes as follows. When two heads are merged in a head-complement relation at the beginning of a derivation, they are in a symmetric c-command configuration and cannot be linearized by the LCA. To resolve the symmetry, the complement moves to become the specifier of the head. The syntax of noun incorporation bears on this point in an important way. When a verb is merged with a bare noun, the two heads are in a symmetric c-command configuration, which is resolved by the noun raising to SpecVP. If the verb is merged with a full DP complement, however, no symmetric c-

⁵ Unless otherwise stated, all Persian data are provided by Mohammed Hahi-Abdolhosseini, Jila Ghomeshi and Arsalan Kahnemuyipour.

command results and no movement takes place.⁶ This gives us the cross-linguistic generalization that nouns precede verbs in noun-incorporation structures.

The major scientific contribution of this thesis is twofold. First, I account for a robust cross-linguistic generalization which, I believe, has not been previously discussed in the literature. Namely, when a verb takes a bare noun as a complement, we get the order N+V and when the verb takes a full DP complement, we get the order V+DP in VO languages. Second, noun incorporation and a wide range of related phenomena fall out naturally from the theory of linearization proposed here. We do not need to posit any new syntactic mechanisms, so noun incorporation comes for free, in effect. As a consequence, we do not need a variety of different mechanisms to account for the phenomena in (3)–(6). Thus, rather than having to posit different mechanisms to account for noun incorporation and related phenomena, I propose that existing mechanisms can accomplish this task for us.

The thesis is structured as follows. The rest of this chapter gives a brief history of phrase structure starting with Phrase Structure Rules in Chomsky (1957), and outlines the theoretical frameworks within which this study is set – namely Minimalism and Bare Phrase Structure, on the one hand, and Antisymmetry and Dynamic Antisymmetry on the other. The chapter concludes with a discussion of alternative accounts of linearization, in particular, proposals that do not adopt Antisymmetry.

Chapter 2 starts off by outlining some of the theoretical problems inherent in merging Bare Phrase Structure and Antisymmetry and discusses some earlier efforts in this direction. Section 2.2 discusses in more detail the problems raised at the beginning of

⁶ That is, no asymmetric c-command results between the verb and any of the heads inside DP. This will be made clear in chapter 2.

the chapter, and explores the two logically possible ways of redefining the LCA in Bare Phrase Structure terms, both of which have been previously discussed. This section also explores in detail the consequences that each of these approaches would have for the rest of the grammar. Section 2.3 discusses the core problem mentioned above, which is the initial merger of two heads. This configuration is shown to violate the LCA. This section discusses the ramifications of adopting a dynamic view of Antisymmetry, in which Compl-to-spec roll-up is admitted as a solution to this problem. Section 2.4 discusses some other possibilities that are compatible with the theories adopted here and shows how they might be implemented in particular circumstances. Finally, section 2.5 discusses late vocabulary insertion and the Distributed Morphology framework, and how it bears on the current proposal.

Chapter 3 offers the main empirical illustration of the proposal put forth in the previous chapter: an analysis of noun incorporation in Oneida (Iroquoian). It begins with a brief defence of a syntactic approach to noun incorporation and illustrates the various patterns of noun incorporation found in Oneida. The next section presents an analysis of noun incorporation for Oneida and discusses some previous analyses of noun incorporation in Iroquoian. Section 3.4 discusses some other core properties of noun incorporation in Iroquoian, including noun incorporation in ditransitives and doubling. Finally, section 3.5 discusses some properties of Iroquoian DPs.

Chapter 4 discusses putative noun incorporation in gerunds in English, German and Persian. Although the process looks similar in all the constructions in these three languages, minor cross-linguistic differences manifest themselves in interesting ways. The chapter also discusses incorporation of conjoined nominals in Tamil.

Chapter 5 discusses Pseudo Noun Incorporation in the sense of Massam (2001). Data from Niuean and Chamorro are discussed, along with the structure of nominals in these languages. The proposal made here will be shown not to contradict Massam's approach, and to be, in fact, quite compatible with it.

Chapter 6 is a conclusion.

1.1.1. Phrase Structure Rules

Chomsky (1957; 1965) proposes that the grammar must distinguish between principles that determine the structure of sentences in a given language and those deriving the different word orders found for sentences in that language. The former are known as phrase structure (phrase structure) rules and the latter are known as transformations. Consider, for example, the English sentences in (7). Chomsky claims that these three sentences have the same underlying structure and that the surface order for (7)b and (7)c is derived from the underlying structure for (7)a. Phrase Structure rules determine the underlying structure of these three sentences, and the transformations of *wh*-movement and passivization derive the sentences in (7)b and (7)c, respectively.

- (7) *English sentences*
- a. Will bought the book in Toronto.
 - b. Which book did Will buy in Toronto?
 - c. The book was bought in Toronto.

Phrase structure rules take the form shown in (8)a. This rule is read as "X rewrites as Y Z W," where the order of Y, Z and W is simply stipulated. Furthermore, since X must be a single syntactic category, phrase structure rules indicate structural constituency. That is, the string Y Z W forms a constituent dominated by the node X as in (8)b.

(8) a. $X \rightarrow Y Z W$

b.

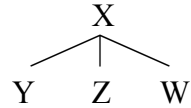

Cross-linguistic differences in word order are captured by stipulation in the phrase structure rules. Thus, an SVO language such as Cantonese or English has the phrase structure rules in (9), while an SOV language such as German or Japanese has those in (10), and a VOS language such as Malagasy those in (11).

(9) *phrase structure Rules for SVO languages*

a. $S \rightarrow NP VP$

b. $VP \rightarrow V NP$

(10) *phrase structure Rules for SOV languages*

a. $S \rightarrow NP VP$

b. $VP \rightarrow NP V$

(11) *phrase structure Rules for VOS languages*

a. $S \rightarrow VP NP$

b. $VP \rightarrow V NP$

Note that the VP rewrite rule in (9)b handles transitive verbs well, but cannot capture intransitives (see examples (12) and (13)). The VP rewrite rule must be amended as in (14), to accommodate the optionality of the direct object.

(12) Milicent coughed

(13) *Milicent coughed the dog.

(14) $VP \rightarrow V (NP)$

Phrase structure rules are problematic from the point of view of more recent generative theory (Chomsky, 1981; Stowell, 1981). They overgenerate in some respects and are redundant in others. I consider first their tendency to overgenerate. Consider the following possible phrase structure rules.

(15) *Hypothetical phrase structure Rules*

- a. $VP \rightarrow (AdvP) V (NP) (PP)$
- b. $VP \rightarrow (VP) V S NP$

The rule in (15)a is fairly standard, but the rule in (15)b is extremely implausible. However, nothing in the theory proposed by Chomsky (1957, 1965) rules it out. Additional mechanisms would have to be postulated to account for the lack of rules such as (15)b.⁷ Also, If the NP in (14) is truly optional, then both (12) and (13) should be grammatical, contrary to fact. Thus, even if the NP is optional, the system still overgenerates.

This brings us to the second problem with phrase structure rules: their redundancy. Chomsky (1981) and Stowell (1981) discuss various types of selectional and subcategorization restrictions on lexical items and propose that lexical entries must encode these restrictions. Thus, a transitive verb such as *smother* selects a direct object NP, whereas an intransitive verb such as *cough* does not. Since each verb must encode whether or not it appears with a direct object NP⁸, it became unclear exactly what the explanatory role of the phrase structure rules is. Such arguments eventually led to the abandonment of phrase structure rules. Furthermore, the introduction of X-bar Theory provided a more constrained mechanism to account for structural properties of language

⁷ Such restrictions have, of course, been postulated. One such restriction, known as endocentricity (Jackendoff, 1977), can be stated as follows, where A and B are variables.

- i. $XP \rightarrow \dots A \dots X \dots B \dots$

Both rules in (15) obey this constraint. See Stowell (1981: 85) for an extended discussion of the inadequacies of phrase structure rules.

⁸ Clearly this is an oversimplification as verbs can also select for clausal complements. Verbs can also specify that their complements be of a certain type, as well, such as declarative, interrogative, etc. See, however, Bošković (1996; 1997) for a proposal on the elimination of c-selection.

thus supporting elimination of phrase structure rules from generative grammar. We now turn to a discussion of X-Bar Theory.

1.1.2. *X-Bar Theory*

Chomsky (1970) and Jackendoff (1977) develop a representational theory of phrase structure, which holds that all phrases exhibit the following structure, linear order aside:⁹

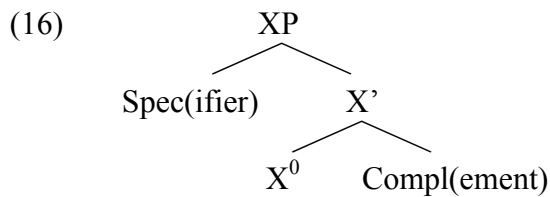

Heads (X^0) necessarily project a maximal projection (XP). The complement is the sister of the head and the specifier is the sister of the highest X' -projection. Adjuncts are either attached to intermediate X' projections or adjoined to the XP, forming a two segment category.¹⁰ X-Bar Theory accounts for endocentricity and the adjacency requirement of heads and their complements without further stipulation.

X-Bar Theory was proposed to account for the structural properties of language, such as constituency, but not for linear order. Linear order is established by a separate module of grammar that deals with directionality. This is the topic of the next section.

1.1.3. *The Headedness Parameter*

In order to account for cross-linguistic differences in word order, the headedness parameter (also known as the ‘directionality parameter’) was proposed (Chomsky, 1981;

⁹ Jackendoff (1977) actually proposes a three-tiered structure, where the higher “specifier” is reserved for non-restrictive modifiers and the lower “specifier” is reserved for restrictive modifiers. The sister to the head is the complement, as in (16).

¹⁰ See Speas (1990) for a discussion of this distinction. Specifically, she proposed that theta-related adjuncts are attached to an intermediate X-bar projection and that non-theta-related adjuncts are adjoined to the XP. Some aspects of this distinction will be taken up later in the discussion of adjunction, so I delay a more detailed discussion until then.

Stowell, 1981; Travis, 1989 inter alia). This parameter gives rise to four structural types of phrases, shown in (17) (S=specifier, H=head, C=complement).¹¹

(17) Four Structural Types of XPs

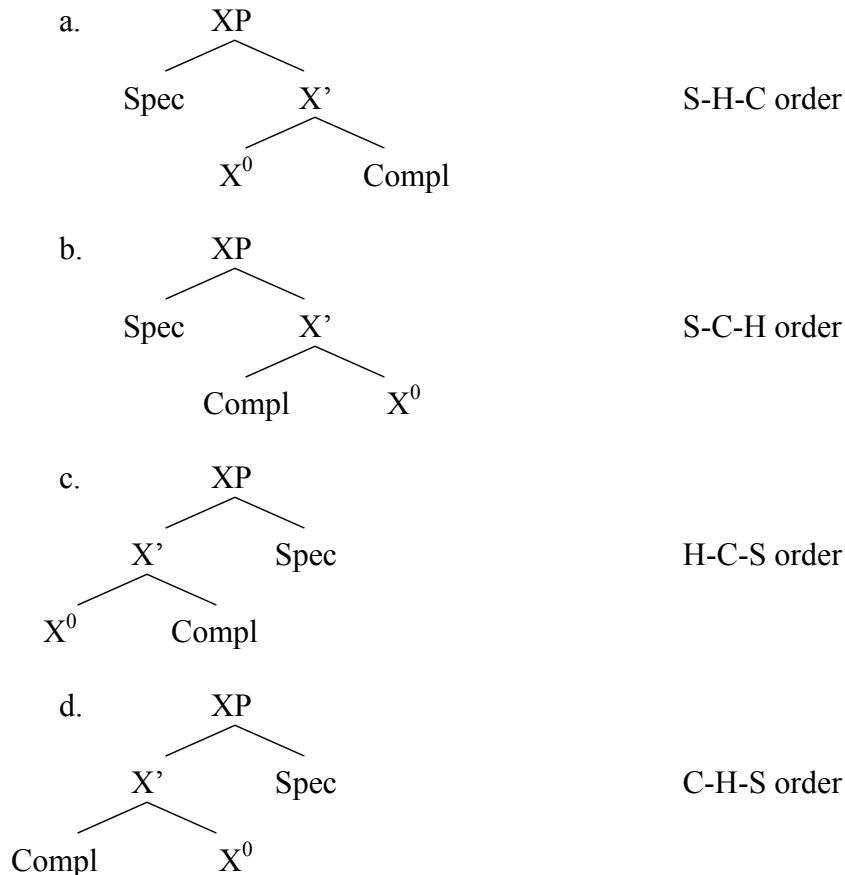

The prevailing view, introduced nearly simultaneously by Stowell (1981) and Chomsky (1981), was that the headedness parameter was a category-neutral specification of the linear order of the specifier, head and complementizer in a given language. The effect of this approach was that clusters of word order properties (postpositions, post-nominal determiners, and OV order versus prepositions, pre-nominal determiners, and VO order; see Greenberg, 1963) could be easily accounted for with one parametrically determined setting for headedness of all XPs. In contrast to this is the view that different syntactic

¹¹ See Giorgi and Longobardi (1991) for a proposal on the headedness parameter for noun phrases.

categories can be assigned different parameter settings. As we shall see directly, this possibility leads to over-generation.

There are several problems with the headedness parameter, however. First, it offers no account for the uneven distribution of the four possible settings among the world's languages. Given the apparatus outlined above, we would expect a fairly even distribution of the four possibilities since, presumably, all four possibilities are freely available. Table 1 gives the relative frequency of the six logically possible neutral word orders and their corresponding setting of the headedness parameter. Note that VSO and OSV word order cannot be derived strictly by the headedness parameter since the verb and its complement are not adjacent.

Table 1 Frequency of Word Order Types among the World's Languages (Ruhlen, 1975)

Order	Frequency	Headedness
SOV	51.5%	S-C-H
SVO	35.6%	S-H-C
VSO	10.5%	--
VOS	2.1%	H-C-S
OSV	0.2%	--
OVS	0%	C-H-S

Table 1 shows an extremely uneven distribution, which is unexpected in the absence of further qualifications. Indeed, this fact was one of the original reasons that a universal order was proposed for the specifier, head and complement.¹²

Another problem with the headedness parameter is the phenomenon of mixed headedness. Ideally, once a parameter is set, it should hold for all categories in the language. Although some languages, such as English and Japanese, appear to be quite

¹² We shall see that the exact formulation of the Universal Base Hypothesis is still a matter of debate. On the basis of the data in Table 1, it comes as no surprise that the two contenders for this hypothesis are the S-H-C order (Kayne 1994, *inter alia*) and S-C-H order (Fukui and Takano 1998, *inter alia*). Still, others have proposed that the directionality parameter specifies only the order between the head and the complement, with the specifier universally on the left (Ernst, 2003; Oishi, 2003).

consistent in their respective settings for the headedness parameter, there are others, such as Germanic languages other than English, for which the parameter settings would have to be different for different categories. Once the possibility of mixed parameter settings is allowed, the number of possible language types increases dramatically, and the grammar severely overgenerates the number of language types.^{13, 14}

The headedness parameter has nothing to say about the placement of adjuncts. In other words, left-adjunction and right-adjunction are both freely available in UG, with no explanation for the restriction on observed orders. Cinque (1999) proposes that most, if not all, adverbial adjuncts are actually specifiers of functional projections that form part of the clausal architecture. This approach reduces the overgeneration to some extent, since many “adjuncts” are now “specifiers”. As a specifier, the adverbial must appear in the position dictated by the headedness parameter or by whatever theory of word order is adopted. There are, however, observable differences between adjuncts and specifiers (Chomsky, 2001a; Rubin, 2003), discussed in section 1.2.1 below. Thus the notion of adjunct must be maintained at some level, leaving open the possibility of both left- and right-adjunction. Note that an analogous problem arises with head-movement; namely, that head movement can occur as left- or right-adjunction. We address this issue separately in section 1.2.5, however.

Finally, Nakajima (1999) also points out that one of the goals of Bare Phrase Structure is to pursue a derivational rather than a representational approach to phrase structure. He suggests that the representational nature of the headedness parameter is

¹³ See Travis (1989) who refines the headedness parameter into two directionality parameters (one for Case assignment and one for θ -role assignment), which deals with some of the problems of mixed headedness.

¹⁴ Mixed headed languages are currently being used as empirical fodder for refining Antisymmetry. See, for example, Zwart (1997), Kandybowicz and Baker (2003) and Aboh (2004a).

inconsistent with the derivational approach of Bare Phrase Structure. Specifically, Nakajima argues that the headedness parameter is a condition on the representation of a syntactic structure and that what is needed is a derivational approach to linearization.¹⁵, ¹⁶

We have seen various problems with the headedness parameter in this section. First, there was no explanation for the relative rarity of those settings of the parameter in which the specifier appears to the right of the head and complement. Second, there was the problem of mixed headedness. The possibility that categories in a given language can have different headedness settings leads to over-generation of possible language types. The issue of left- versus right-adjunction was mentioned, and it was noted that free use of either direction of adjunction offered no explanatorily adequate account of the observed word order differences in language with respect to adjuncts. This is an important point since it bears on a common objection to Antisymmetry. Opponents of Antisymmetry often complain that movement is too unconstrained and thus lacks any explanatory adequacy. This is a by-product, of course, of a highly constrained system of phrase structure. Proponents of the head-parameter approach can appeal to the constraints on movement within a Minimalist approach. However, as I have pointed out above, the head parameter approach is unconstrained leading to over-generation and thus lacks explanatory adequacy. Thus, one cannot argue against Antisymmetry on the basis of unconstrained movement, since the head parameter approach simply replaces unconstrained movement with unconstrained phrase structure. Finally, Nakajima (1999) points out that the representational nature of the headedness parameter is inconsistent

¹⁵ Nakajima offers such an approach, which I argue against later. My proposal is also a strongly derivational approach to linearization.

¹⁶ Wojdak (2005), in fact, does propose a derivational approach to word order assuming an updated version of the head parameter. Again, however, such an approach suffers from many of the same problems as the traditional head parameter as described in this section, including over-generation.

with the derivational nature of Bare Phrase Structure, and that a derivational approach to linearization is to be preferred.

The next section outlines the theoretical approach in which the proposal in Chapter 2 is framed: Bare Phrase Structure (Bare Phrase Structure) and Antisymmetry. The end of this section has a short discussion of head movement and its elimination from UG.

1.2. Theoretical Assumptions

1.2.1. Bare Phrase Structure

Since early Minimalist efforts (Chomsky, 1993, 1994, 1995) it has been assumed that X-bar theory is an extraneous mechanism that complicates the grammar. Instead, syntactic structures are built by a simple pair-wise merge algorithm under the rubric of Bare Phrase Structure.

Thus, rather than assuming a theory of phrase structure that constitutes a module of UG (X-bar Theory), Bare Phrase Structure takes a minimalist approach, using no theoretical machinery that is not absolutely necessary. To this end, we assume that Bare Phrase Structure consists minimally of the operation Merge, which takes as its input two elements, α and β , and gives as its output the unordered set $\{\alpha, \beta\}$. Furthermore, we assume that the unordered pair must have a label of some sort in order to be accessed by subsequent instantiations of Merge. We call this label γ , and express the result as follows:

$$(18) \quad \{\gamma, \{\alpha, \beta\}\}$$

There are various possibilities as to the nature of γ , all of which are considered in turn in Chomsky (1994). He concludes that the label is an identical copy of the head of the element that projects. So, if α projects, then the label is α .

Furthermore, we assume that the derivation makes a one-time selection of lexical and functional elements from the Lexicon and holds these in the Numeration (N).¹⁷ Each item in N is assigned an index expressing the number of times it is selected. For instance, in the sentence, *John's hamster bit Mary's hamster*, both *hamster* and *'s* will be assigned an index of 2, since they appear in the sentence twice.

The operation Merge operates over lexical items and syntactic entities (an independent set formed by Merge); thus only the top-most nodes in a tree are eligible to participate in Merge.¹⁸ Suppose we have the two phrase markers shown in (19)a and b. They can participate in Merge to give the structure in (19)c (assuming *a* projects) but there is no way to merge one of the phrase markers with a subcomponent of the other. In other words, Merge must operate cyclically.

(19) *Merger of Phrase Markers*

a. $K = \{a, \{a, b\}\}$ ¹⁹

b. $L = \{c, \{c, d\}\}$

c. $\text{Merge}(K, L) = \{a, \{\{a, \{a, b\}\}, \{c, \{c, d\}\}\}\}$ (if *K/a* projects)

Before proceeding to the next section, a comment is in order about how phrase markers are represented here. For a phrase such as [_{DP} the dog], I assume that the three representations in (20) (where other functional projections such as NumP and *n*P have

¹⁷ I do not address here the question of sub-Numerations and phases.

¹⁸ Citko (2005) argues for *parallel merge*, which is counter-cyclic, however. See also Richards (1998) on tucking in.

¹⁹ For consistency throughout, when lexical items are represented by Roman letters, I use standard font for labels and *italic* font for the actual lexical items.

been omitted for the sake of discussion) are notational variants. I use phrase markers as in (20)c throughout the rest of this thesis, since most readers are familiar with this type of notation. Thus, I ask the reader to ignore the X-Bar baggage that comes with the structure in (20)c and assume a Bare Phrase Structure representation.

(20) *Representation of Phrase Structure*

a. {the, {the, dog}}

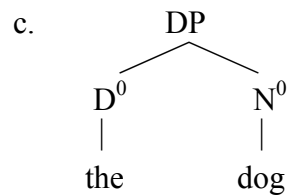
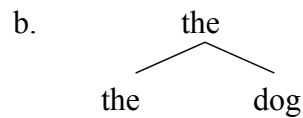

1.2.2. *Adjunction*

Prior to *Beyond Explanatory Adequacy*, (Chomsky, 2001a), Chomsky proposed two types of Merge: set Merge (substitution) and pair Merge (adjunction). Formally, the difference between the two is the nature of the label of the set formed by Merge. Set Merge works as illustrated in (19), while pair Merge is identical except that the label is an ordered pair, $\langle a, a \rangle$, giving rise to the set $\{\langle a, a \rangle, \{a, b\}\}$. Chomsky (2001a), simplifies the adjunction operation so that adjunction of a to b forms the ordered pair $\langle a, b \rangle$ rather than an unordered set with a two-headed label, $\{\langle a, a \rangle, \{a, b\}\}$. Set Merge is unchanged, giving rise to $\{a, \{a, b\}\}$. Regardless of the set-theoretic composition of adjunction structures, Chomsky assumes that the adjoined XP (here a) does not participate in any new relations formed by the growing tree structure (c-command, etc.), and that b

participates in the same relations that would have existed if adjunction had not taken place. In other words, adjunction does not change the relation of the phrase it adjoins to with the rest of the sentence. Evidence for this view of adjunction comes from anti-reconstruction effects.

(21) [Which picture of herself_j that John_i likes] did he_i ask Mary_j to buy *t_{wh}*?

In (21), the *wh*-phrase must reconstruct to the trace position indicated in order for the anaphor to be licensed. In reconstructing, however, we would expect a Condition C violation since *John* is c-commanded by a coreferential pronoun. The sentence, however, is grammatical, supporting the claim that the adjoined XP (underlined) does not participate in any new relations with the rest of the structure. The following sentence, now, is problematic for the picture drawn so far.

(22) *He_i knows which picture of herself_j that John_i likes Mary_j bought.

In (22), regardless of whether the *wh*-phrase reconstructs, a condition C violation is created by the pronoun, *he*, in the matrix clause. To account for data such as this, Chomsky proposes an operation *Simpl* (=simplify) that converts an adjoined structure $\langle a, b \rangle$ to a set Merged structure $\{a, b\}$, which participates in structural relations as any set merged phrase does.

Another major proposal for adjunction holds that adjuncts are merged “late” or post-cyclically (Lebeaux, 1988, 1991; Speas, 1990; Stepanov, 2001a).²⁰ The idea behind these proposals is that the adjunct merges to its host phrase after all overt transformations have taken place. This is shown in (23).

²⁰ Not discussed here are two other proposals for adjunction structures. The first is Rubin (2003), who proposes a Mod(ifier)P shell to host adjunction. He proposes that it is a property of ModP that properties of the pre-existing structure (c-command, etc.) do not change. The other proposal is that of Safir (1999), who proposes that antireconstruction effects in adjunction structure are due to vehicle change, thus eliminating the need for any special structural apparatus for adjuncts.

(23) *Postcyclic Merge of Adjuncts*

- a. He did purchase [DP what photo] *base structure*
- b. [DP what photo] did he purchase [DP what photo] *transformations*
- c. [DP what photo [that John¹ likes]] did he¹ purchase
[DP what photo] *add adjunct*
- d. [DP what photo [that John¹ likes]] did he¹ purchase
~~[DP what photo]~~ *delete lower copies*

The formal distinction between set Merge and pair Merge is distinguish selected from non-selected entities merged in the derivation. Selected elements are introduced by set Merge (substitution), while non-selected elements (adjuncts, adverbs, etc.) are introduced by pair Merge (adjunction).²¹

Another well-known property that distinguishes adjuncts from arguments is extractability. XPs cannot be extracted from adjuncts; whereas there is no restriction on extracting from an argument (assuming other principles and constraints are satisfied). The pair in (24) illustrates this property, where α is a complement and β is an adjunct.

(24) *Adjunct/Argument Extraction Asymmetry*

- a. Which book_{*t*} do you think [α that John likes *t*]
b. *What_{*t*} did you sleep [β while John read about *t*]

²¹ Another property that the substitution/adjunction distinction was originally intended to capture was the distinction between A- and A'-positions. Alexiadou (1997) points out, however, that some specifier positions (such as SpecCP) are A'-positions, and that the A- versus A'-distinction must be captured by other means.

It is not the case, however, that all adjuncts behave uniformly with respect to extraction. The following examples illustrate that extraction is possible from PP adjuncts to the VP (but not from adjuncts to the NP).²²

(25) *Extraction from PP Adjuncts*

- a. John read a book in the kitchen. (ambiguous)
- b. Which room did John read a book in? (VP-level reading only)

Furthermore, the adjuncts that permit extraction pattern with arguments with respect to Condition C upon reconstruction. Consider the following examples.

(26) *Condition C Violations upon Reconstruction*

- a. Which picture on John_i's living room wall does he_i like the most?
- b. Get undressed while anyone was looking at John_i, he_i never would!
- c. *Eat tuna in John_i's bathtub, he_i never would!
- d. Read the books on John_i's bookshelf, he_i never would! (NP-level reading only; * on VP-level reading)
- e. *Which report that Peter_i is intelligent did he_i publish?

(26) shows that PP modifiers of a DP (a) and clausal modifiers of a VP (b) exhibit anti-reconstruction effects. That is, there is no Condition C violation upon the putative reconstruction of the raised element to its base position.²³ These are the same types of modifiers that block extraction. On the other hand, PP modifiers of VPs (c, d) and DP complements (e), which allow extraction, are sensitive to Condition C upon reconstruction.

²² As pointed out by Bouchard (2002), an NP-adjunct can be extracted from if the adjunct is considered an integral part of the head noun.

- i. Which car do you like the steering wheel on?
- ii. *Which car do you like the girl in? (ok as a small clause, but not as an adjunct)

²³ Recall that reconstruction is necessary for sentences such as *Which picture of herself_j does Mary_i like?*

It has been argued that many PP modifiers of the VP appear directly in the argument structure of the VP (Larson, 1988, 1990). Thus, a sentence such as *John read a book on Tuesday* would treat the XPs *a book* and *on Tuesday* as arguments of the VP. These “adjuncts” do not exhibit anti-reconstruction effects and can be extracted from.

(27) *Extraction from VP-level PP adjuncts*

- a. Which day did John read a book on *t*?
- b. Which room did Mary eat the grapefruit in *t*?

The distinction between *true* adjuncts (which exhibit anti-reconstruction effects) and *argumental* adjuncts inside a Larsonian shell (which do not exhibit anti-reconstruction effects) will be important in the discussion in Chapter 2.

1.2.3. *Move*

In order to account for the displacement property of language in a constrained and consistent way, constituents that fulfil the same semantic role (i.e., bear the same thematic role) are assumed to be merged into the same base position, regardless of where they appear on the surface. Thus, in the sentences, *John stole the book*, *the book was stolen*, and *Which book do you think John stole* the DP containing the word “book” has the same base position in all three sentences. Furthermore, the DPs containing *book* move only in certain syntactic environments (*cf. the book was stolen* versus **the book John was stolen*). In other words, constituents move, but in a constrained manner.²⁴ In the theory of Government and Binding, movement was previously accomplished by an operation,

²⁴ Of course other frameworks do not posit movement to account for “displacement” properties of language. See HPSG (Sag and Wasow, 1999) or LFG (Bresnan, 2001).

Move α . More recently, Chomsky (1995) derives Move from Merge as follows: Given the phrase structure in (28), suppose that AP must raise to SpecBP.

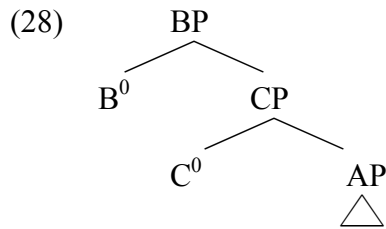

Movement is accomplished by a composite of primitive operations: Copy + Merge (Chomsky, 1995; Nunes, 2004).²⁵ First, AP is copied, and then the copy, an independent phrase marker, is merged with BP.

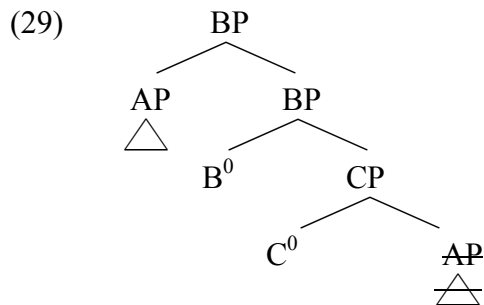

The lower copy is then marked for deletion as indicated by the strikethrough notation in (29). This treatment permits the elimination of Move as a primitive operation. Note that in (29), the category AP looks like an adjunct and the category BP is composed of two segments. The structure could equally have been rendered with B' as the intermediate BP projection with no effective difference, as the specifier/adjunct distinction is no longer maintained.

I now briefly consider the nature of movement in the Minimalist Program and in Antisymmetry, since the two theories have made different proposals about what triggers movement. I do not intend to answer here the question of how movement is to be

²⁵ Nunes' (2004) conception of Move actually consists of a composite of four operations: Copy + Merge + Form Chain + Chain Reduction. The precise formulation of Move does not matter for the discussion here.

understood under an approach that adopts some synthesis of the two theories. Rather, I describe the general approaches and contrast the predictions they make. In Minimalism, movement has had two major motivations. For Chomsky (1993; 1995), movement was seen as a means of removing uninterpretable features from the derivation. These features were typically morphological, and movement was thus essentially driven by morphology. Later on (Chomsky, 2000, 2001b), the operation Agree was assumed to check uninterpretable features *in situ*. As a result, overt movement was required only for the checking of an EPP feature. This second understanding of movement, then, is chiefly phonological. Movement in Dynamic Antisymmetry, as pointed out above, is also motivated phonologically by the need to eliminate instances of symmetry (that is, to eliminate symmetrically c-commanding phonologically overt elements) for the purposes of linearization. Several questions now come to mind. Are both motivations for movement available to UG? If so, at what levels of grammar do they operate? This thesis deals only with the resolution of symmetry as a trigger for movement. Whether both Antisymmetric and Minimalist triggers of movement, namely the resolution of symmetry on the one hand, and EPP and feature checking on the other, are available to natural language and in what capacities will have to wait for future research.²⁶

²⁶ For an overview of current ideas on the source of how movement is triggered, see Breitbarth and Van Riemsdijk (2004).

1.2.4. Antisymmetry²⁷

Kayne (1994) develops a theory of linearization in which c-command relations determine surface word order through the Linear Correspondence Axiom (LCA), given below:

(30) *Linear Correspondence Axiom*

$d(A)$ is a linear ordering of T . [Kayne, 1994: 6]

A is the complete set of ordered pairs $\{ \langle X_1, Y_1 \rangle, \langle X_2, Y_2 \rangle, \langle X_3, Y_3 \rangle \dots \langle X_n, Y_n \rangle \}$ where X_i and Y_i are any two non-terminal syntactic nodes such that X_i asymmetrically c-commands Y_i . $d(A)$ is the mapping from A to the set of ordered pairs of terminals $\{ \langle a_1, b_1 \rangle, \langle a_2, b_2 \rangle, \langle a_3, b_3 \rangle \dots \langle a_n, b_n \rangle \}$ such that a_i is dominated by X_i and b_i is dominated by Y_i . T is the set of terminal nodes. What this means is that when a syntactic node X asymmetrically c-commands a node Y , all the terminal nodes dominated by X precede all the terminal nodes dominated by Y . (30) gives Kayne's (1994) definition of c-command, which is assumed under most versions of Antisymmetry.

(31) X c-commands Y iff X and Y are categories and X excludes Y and every category that dominates X dominates Y . (Kayne, 1994: 18).

This definition is carefully framed so that a head does not c-command its specifier. This will become clear in the discussion of multiple specifiers below.

The following example illustrates how the LCA is implemented. In these examples, a , b , and c are terminals; A , B , and C are minimal projections dominating only terminals, and AP , BP , CP are maximal projections. Consider first example (32).

²⁷ A note is in order here on the difference between the terms *asymmetric* and *antisymmetric*. In mathematical terms, a relation, R , is *antisymmetric* in X , iff $\forall a, b \in X : aRb \wedge bRa \Rightarrow a=b$. What this means is that if two elements are related to each other in the same way, they are the same element. A relation, R , is *asymmetric* in X , iff $\forall a, b \in X : aRb \Rightarrow \neg(bRa)$. What this means is that if a element, a , is related to another element, b , then b does not hold that relation with a . The reader is referred to Partee *et al.* (1993) for further technical discussion on this matter. In this thesis, I use the term *Antisymmetry* to refer to the theory of linearization in which ordering relations are dependent on c-command. Note that the approach taken in this thesis is distinct from but in line with Asymmetry Theory (Di Sciullo, 2005), where only asymmetric relations can licence any kind of dependency.

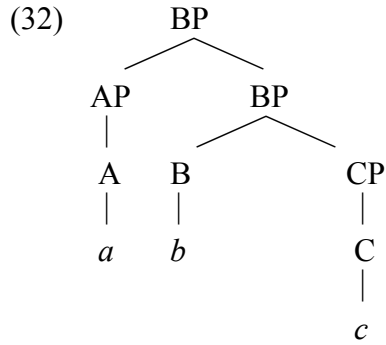

The set A , upon which the LCA will be evaluated, consists of the set of ordered pairs in (33), which gives rise to $d(A)$ in (34), the mapping from A to the set of pairs of ordered terminals, as explained above.

$$(33) \quad \{ \langle AP, B \rangle, \langle AP, CP \rangle, \langle AP, C \rangle, \langle B, C \rangle \}$$

$$(34) \quad \{ \langle a, b \rangle, \langle a, c \rangle, \langle b, c \rangle \}$$

In order for a derivation to be linearized, every terminal node must be ordered with respect to every other terminal node, either directly, or by transitivity. In other words, linear ordering must be total. Furthermore, linear ordering cannot be contradictory. That is, if a node A c-commands B , then no element inside B , including B itself, can c-command A or anything inside A . Such a configuration would result in contradictory linearizations and the derivation would crash at the level where the LCA is evaluated.

As a result of the LCA, tight restrictions are placed on phrase structure. Each maximal projection can contain only one specifier or one adjunct. Multiple adjunction or adjunction to a maximal projection that already has a specifier is prohibited. This is because the two adjuncts, or an adjunct and a specifier to the same maximal projection cannot be linearized with respect to each other. This is shown in the following example:

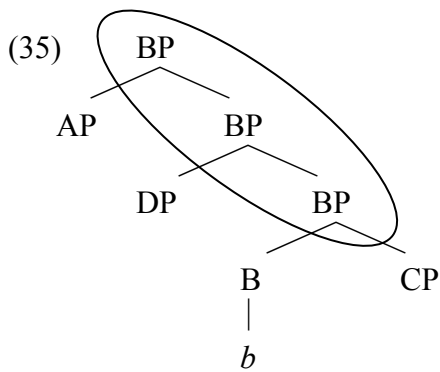

Here BP has either two specifiers, or two adjuncts, or an adjunct and a specifier. There is no asymmetric c-command relation between AP and DP in this structure under Kayne's definition of c-command. The reason for this is that the three instances of BP in example (35) constitute a single category. Thus, B is dominated by BP, but AP and DP are not. They are thus not dominated by any category in this structure. In order for a category β to dominate an element α every segment of β must dominate α . Since the lowest segment of BP does not dominate either AP or DP, the category BP does not dominate either of these elements. Even if another head, E, merges with BP, the lack of asymmetric c-command between AP and DP remains, and their linear order remains unresolved:

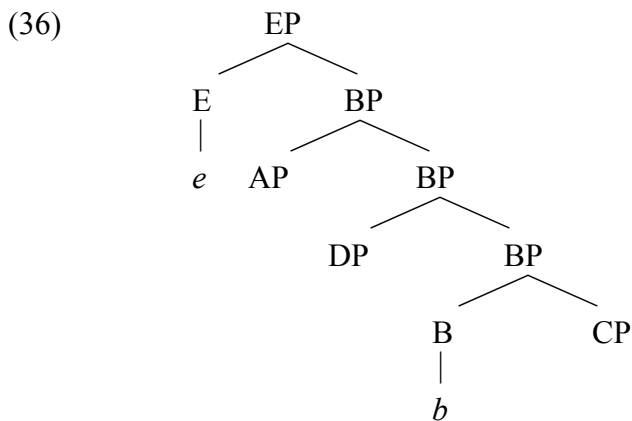

In (36), E c-commands into both AP and DP.²⁸ Also, AP and DP both c-command B; however, there is still no asymmetric c-command relation between AP and DP. As a result, no linear order is established between these two elements and the derivation crashes upon evaluation of the LCA.

Consider now a contradictory ordering.²⁹ In (37), BP asymmetrically c-commands C, and CP asymmetrically c-commands B. This gives rise to the set A in (38), and its image under the function d in (39). We see that $d(A)$ contains the contradictory ordering $\langle b, c \rangle$ and $\langle c, b \rangle$, and the derivation crashes.

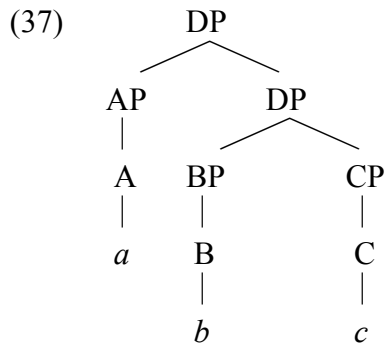

(38) $\{\langle AP, B \rangle, \langle AP, CP \rangle, \langle AP, C \rangle, \langle BP, C \rangle, \langle CP, B \rangle\}$

(39) $\{\langle a, b \rangle, \langle a, c \rangle, \langle b, c \rangle, \langle c, b \rangle\}$

Under Dynamic Antisymmetry (Moro, 2000, 2004), the LCA is a PF constraint deriving from bare output conditions required for the articulo-perceptual interface.³⁰ Thus, the LCA holds only at the PF level of grammar. The bare output condition is simply that a linear order must be derived from the output PF receives from the syntax.

²⁸ Note that E is in a symmetric c-command relation with both AP and DP since E, AP and DP are all dominated by the same set of maximal projections (only EP), but that E asymmetrically c-commands both A and D (not shown). Thus, e can be ordered with respect to a and d . The crucial point here is that there is no way that a and d can be ordered with respect to each other.

²⁹ Note that the DP in (37) does not have a head. The inadmissibility of this kind of structure can be used to derive endocentricity. Thus, just as Kayne removes X'-Theory as a primitive from UG, deriving it instead from the LCA, endocentricity can also be removed as a primitive from UG. See Moro (2000), however, who uses the point of symmetry in the structure in (37) for small clauses.

³⁰ Chomsky (1995: 337) actually suggested this in a brief discussion of Romance clitics.

Following Moro (2000), we call this the weak antisymmetric view. This contrasts with Kayne (1994), who assumes that the LCA must hold throughout the derivation. Kayne’s original motivation for assuming that the LCA holds at every level of grammar and throughout the derivation (the strong antisymmetric view) has to do with the role of X-bar theory. Kayne’s original proposal sought to derive the properties of X-bar theory from Antisymmetry, thus eliminating X-bar theory as a primitive from UG. Since it was assumed that the principles of X-bar theory held at every stage of the derivation, Kayne assumed that the LCA should also hold throughout the derivation. Since X-bar theory has been shown not to be necessary in the Minimalist Program, there is no compelling reason to assume that the LCA must hold throughout the derivation. As Moro points out, since the LCA is concerned with linear order – a phonological aspect of language – there is no reason to assume that it holds anywhere but at PF.

Under Moro’s Dynamic Antisymmetry approach, symmetric c-command serves as a trigger for movement. Movement, in this case, is the search for asymmetric c-command so that the LCA is satisfied. Moro discusses three specific contexts in which symmetric c-command holds, shown below.

(40) *Symmetric C-Command*

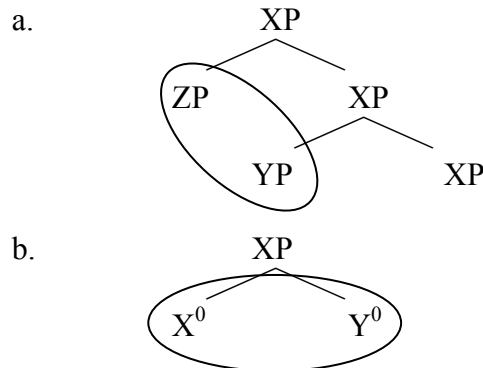

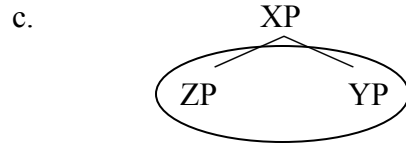

In these three examples, the elements in the ovals c-command each other. Moro proposes that this symmetry acts as a trigger for movement. In fact, Moro pursues a research program in which symmetry, not morphology, serves as the sole trigger for movement.³¹ In this dissertation, I will be concerned only with the type of symmetry illustrated in (40)b.

To summarize, the LCA requires that all terminal heads enter into a non-contradictory linear ordering. The LCA is evaluated at the PF interface (following Moro, 2000 but *contra* Kayne, 1994). Movement can eliminate instances of symmetry, and Moro takes this to be its major motivation. He does ask whether there are other motivations for movement, but leaves the question unanswered.³² If there is a choice as to what to move to eliminate symmetry, other properties of the grammar, in principle, may come into play.

The preceding paragraphs have discussed the principles of Antisymmetry that are required for the proposal for phrase structure in chapter 2. We now turn to head movement and its status in UG.

1.2.5. *Head Movement*

According to Kayne (1994), head-adjunction is possible, but only to the left side of the host. More recently, however, it has been assumed that head-movement is not

³¹ See, for example, (Baauw, 1998; Guasti and Moro, 2001; Koncar, 2005) for developments in this direction.

³² Moro acknowledges that it may be difficult or even impossible to treat all cases of movement as the resolution of symmetrical constructions. He admits that other possible triggers for movement such as checking Case in passives or EPP may have to be admitted in UG.

permitted, or is restricted in some way (Chomsky, 2000; Fanselow, 2003; Harley, 2004; Kayne, 2003b; Koopman and Szabolcsi, 2000; Mahajan, 2003). I discuss here some of the properties of head movement and the problems involved in restricting or eliminating it entirely. First, however, I begin with a brief discussion of head-movement within an early minimalist framework.

In his discussion of head movement, Chomsky (1995) invokes uninterpretable [V-] features and [N-] features to account for verb-movement and NP-movement in languages such as English, French and Icelandic. In French, for instance, T^0 hosts a strong [V-] feature that must be checked by overt verb raising. In both English and French, T^0 also hosts a strong [N-] feature (the EPP), which attracts the subject NP to SpecTP. The question that arises here is why the [V-] feature is satisfied by head-movement while the [N-] feature is satisfied by XP-movement. As it stood, this difference had to be stipulated.³³

The elimination of head-movement from UG solves this problem by leaving XP-movement as the only type of movement. This also results in a simplification of the grammar, since it reduces the number of options available to the learner to account for displacement. Consider the following scenario, in which we see the underlying and derived order of a sentence.

- (41) *Underlying versus derived order in a hypothetical language*
- a. A...B...C (underlying)
 - b. B...A...C (derived)

³³ Massam (2000b) proposes that VOS word order in Niuean arises when the VP moves to satisfy EPP in SpecTP. Thus we see here an example of a strong [V-] feature being satisfied by XP-movement. Oda (2003; 2005) also proposes a VP-raising analysis to account for certain word order facts in Irish. Aboh (2004b) also discusses cases of VP movement and N^0 movement.

It is clear that B has raised from its base position to the left periphery of the structure. This movement could in principle be accomplished either by head-movement or by XP-movement as shown in the following phrase markers. In the following examples, X and Y are phonologically null.

(42) *Phrase markers for hypothetical language*

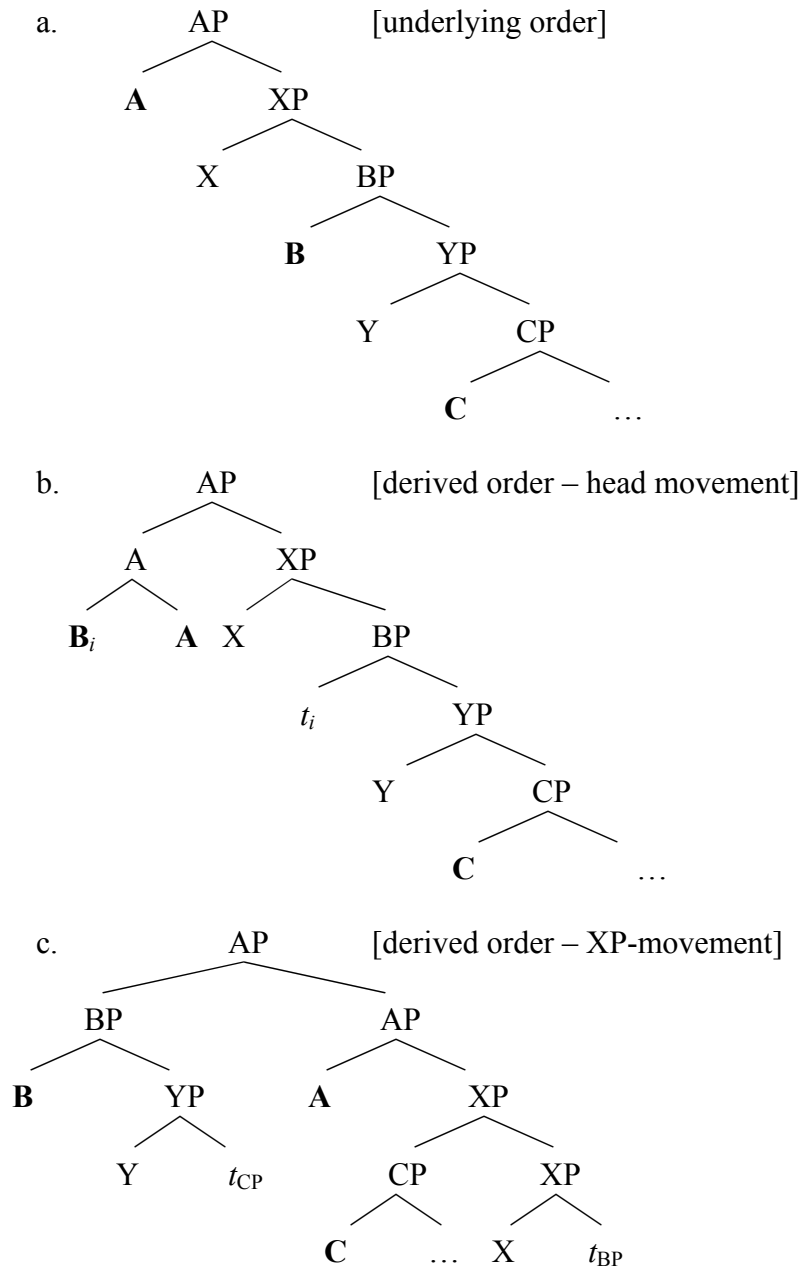

In (42)c, CP moves to SpecXP, then the remnant BP moves to SpecAP. The result is that the same word order is derived in (42)b and (42)c. If the heads X and Y are phonetically null, there is no *a priori* way to distinguish between these two analyses. From the child's perspective, then, having two possible transformations available to account for the same overt displacement severely complicates language acquisition in a way that a model of grammar that holds that head movement does not exist does not.

Another problem with head-movement is the lack of a clear understanding of how it works in Bare Phrase Structure. In X-Bar Theory, phrasal movement can be either adjunction or substitution, but it was never clear which of these two types head movement should be.³⁴ It is not clear how to maintain this distinction for head movement within Bare Phrase Structure. In X-Bar Theory, nodes were assigned bar levels derivationally as in (43)a, but this option is not available in Bare Phrase Structure. In Bare Phrase Structure, only a terminal is a head. Thus, when a head, X^0 , adjoins to another head, Y^0 , Y^0 cannot project to Y^0 , since Y^0 by definition is a terminal. This is shown in (43)b. Whatever type of projection $Y^?$ is in (43)b, it is not a Y^0 since it is not a terminal. In fact, it is not clear how $Y^?$ would differ from YP , unless extra stipulations are added to Bare Phrase Structure.

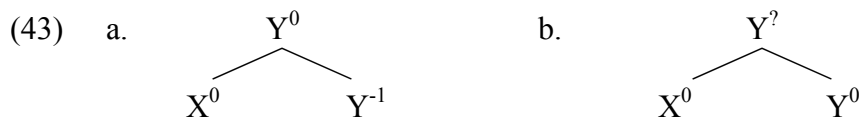

The fact that when X^0 adjoins to Y^0 , the resulting category cannot be a head, leads into the next problem with head-movement. As Mahajan (2003) points out, the moved head, X^0 , does not c-command its trace whether c-command is defined as by Kayne (1994), as in the core proposal to be made here (see Chapter 2), or with respect to the first

³⁴ See Harley (2004) for discussion of this point.

branching node. Thus, under no definition of c-command does a raised head c-command its trace.

The elimination of head-movement from UG also solves the problem of counter-cyclicity, which is inherent to head-movement. Strict cyclicity requires that moved or external elements merge with the root projection only. Since head-movement requires the head to merge into a position lower than the root, cyclicity is violated.³⁵ As the arrow indicates in (44), head-movement does not target the root of the phrase structure (XP), but rather something below it (X^0).

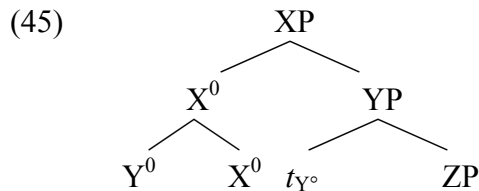
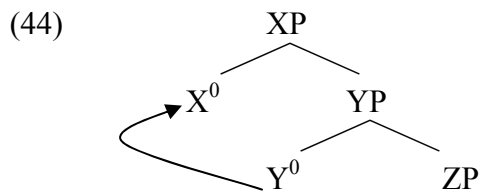

Holding to cyclicity, the possibility remains that the head Y^0 in (36) could raise and merge with the root XP. Under X-bar Theory, it was stipulated that such a movement would be ruled out, since only phrases, and not heads, could occupy the specifier position.³⁶ It has also been noted (Chomsky, 1995: 321; Harley, 2004; Toyoshima, 2000: 44) that head-movement violates Uniformity of Chains (Chomsky, 1994) since, prior to movement, the head is a minimal projection and after movement, the moved element is both a minimal and a maximal projection. Although Kayne (1994) also states that this is

³⁵ See Fanselow (2001) and Mahajan (2003) for an extended discussion of this and other problems with head-movement.

³⁶ Jackendoff (1977) actually notes that specifiers, but not complements can be heads, but for different reasons than we are assuming here. Jackendoff's statement was made under much older assumptions where what are now treated as functional heads were thought to occupy specifier positions.

an illegal move, nothing within Antisymmetry rules it out.³⁷ This leads us back to our original problem. How does the derivation know whether to move a head or an XP? Under the previous assumption that overt displacement is triggered by the need to satisfy an uninterpretable feature, [*u*F], this feature must probe a target with a matching feature [F]. Thus, the computation searches downward until it finds the first instance of a matching feature. If this feature is contained within a head that has not projected, then the head is copied and internally merged. If the feature is found on the label of a projection, then the computation targets the node containing that label, which is then copied and internally merged. Under this approach, a head will never be available for movement, unless it is also a maximal projection. This is illustrated in the following structures. In these examples, the feature [F] is being probed and targeted for movement. Recall, following Bare Phrase Structure, that any features that appear on a head, X^0 , also appear on XP, since XP has X^0 as its label.

(46) *Probing a feature* [F]

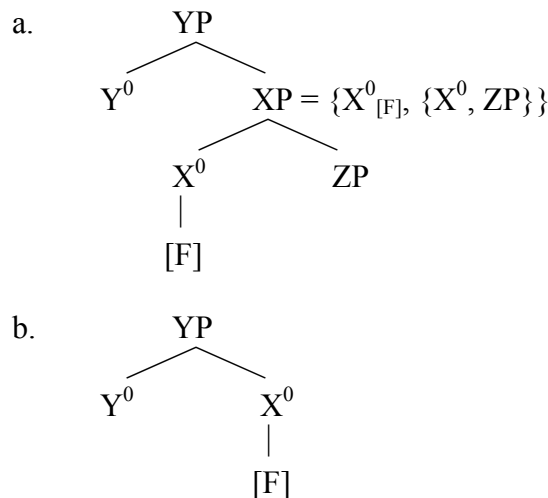

³⁷ Dobrovie-Sorin (1994), for instance, argues that pronominal clitics in Romanian raise to SpecIP, rather than to I^0 , a move made possible due to the fact that clitics, following Chomsky (1995), are both maximal and minimal projections. Bošković (2002) also argues that clitics are heads that occupy the specifier of a functional projection. Since we take up the topic of clitics later, I will hold off on the details.

In (46)a, if the feature [F] is probed by a higher element, only the XP is visible since it is closer to the probe than its head X^0 . Thus, X^0 will never be targeted for movement. In (46)b, of course, the head X^0 is the only element bearing the feature [F].

Bobaljik and Brown (1997) propose a solution to the problem that head movement creates for cyclicity. They suggest that interarboreal movement is possible (sideward movement in Nunes' (2004) terms). Their approach assumes that the derivation proceeds in parallel. Thus, in (47), there are two phrase markers being built up "simultaneously".

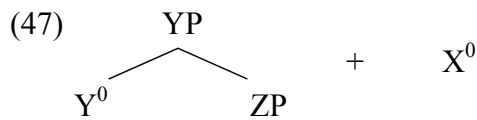

Copy Y^0 and merge with X^0 .

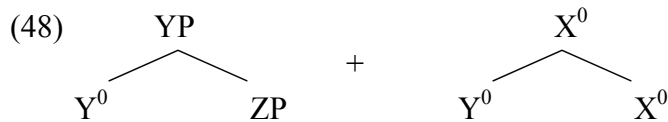

Merge X^0 and YP. Delete lower copy of Y^0 (presumably at PF). If we assume that the raised head Y^0 must c-command the lower copy, we must assume that X^0 does not dominate Y^0 since not every segment of X^0 dominates Y^0 .

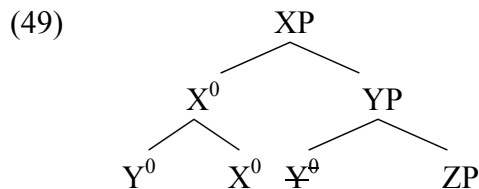

Note that the resulting structure in (49) is isomorphic to that of (45).

This approach solves the cyclicity problem since in all cases only the root of a phrase marker participates in Merge, but it still does not answer the question of how the system knows whether to raise a head or a phrase. In the first stage in this derivation

shown in (47), the computation could just as easily have chosen to copy Y^0 and merge it with X^0 , giving a structure without any head movement. It is also not clear how the computational system knows not to project a maximal projection (XP instead of X^0) in the second stage, given in (48). Under normal circumstances, merging two heads creates an XP , not a complex head. Thus, if we merge a verb and a bare noun, we get a VP , not a complex verbal head.

(50) *Initial Merger of Two Heads*

a. Merge (V^0, N^0) \rightarrow [$_{VP} V^0 N^0$]

b. Merge (V^0, N^0) \nrightarrow [$_{V^0} N^0 V^0$]

Why then, do we get a complex head [$_{X^0} Y^0 X^0$] in example (48), rather than an XP [$_{XP} X^0 Y^0$]? Bobaljik and Brown argue that when the two heads are merged, they undergo Pair Merge rather than Set Merge; in other words, the moved head is adjoined to the host head. Since adjunction does not project a new category, but rather just extends the category being adjoined to, then X^0 simply projects another segment of X^0 when Y^0 adjoins to it.

This approach is problematic on two grounds. First, recall that I argued above that head adjunction conceived as just described is problematic in a Bare Phrase Structure framework. As soon as X^0 projects, it is no longer a minimal projection, and is thus indistinguishable from a maximal projection, regardless of one's view of adjunction. Second, head movement of this type does not seem to fit the usual notion of adjunction.³⁸ Adjuncts do not satisfy any selectional restrictions of the host, nor do they check any

³⁸ Recall that I have adopted the stance that there is no distinction between specifiers and adjuncts, indicating that a special type of Merge for adjuncts does not exist. This, of course, is immediately problematic for an analysis which treats head movement as adjunction. Under the view that adjunction does exist as a distinct operation, head movement is still problematic for the reasons described above.

features of the host. Indeed, when we explain the concept of an adjunct to novice students, it is usually described as “extra information not required by the sentence.” However, head movement is usually assumed to check a feature, such as a [μ V] feature on T^0 (Chomsky, 1995), or a focus feature (Aboh, 2004a). Thus, head movement, if it exists in the sense understood here, should be Set Merge rather than as Pair Merge, and the account proposed by Baker and Bobaljik would become untenable. Because of these problems with the sideward approach to head movement, I do not adopt it and assume instead that head movement is not available in UG.³⁹

The problem now becomes how to deal with cases previously thought of as head-movement. An XP-movement analysis must be provided for these cases.⁴⁰ Generally, when it appears that a head has raised without its complement, a remnant XP-movement analysis is pursued (see example (42)c above). There is, of course, a vast literature exploring this approach, which cannot be summarized here (Aldridge, 2003; Ambar and Pollock, 2002; Baltin, 2001; Cummings, 2002; Haegeman, 2000, 2001; Kandybowicz and Baker, 2003; Lee, 2000; Massam, 2000b; Muller, 1996; Müller, 1997, 2004; Takano, 2000 *inter alia*). The current study extends the remnant XP-movement approach to the domain of noun incorporation – a process which has been previously treated as involving head movement (Baker, 1988).⁴¹

³⁹ I leave aside here the question of whether head movement is available strictly as a PF process. See, for example Boeckx and Stjepanovic (2001).

⁴⁰ Or, as Elizabeth Cowper has pointed out to me, an analysis in which no movement takes place can be pursued; that is “moved” heads are initially merged in the higher position rather than raised there from a lower position.

⁴¹ At least as far as syntactic analyses are concerned. There are, of course, many analyses of noun incorporation which treat this phenomenon as lexical rather than syntactic. I address this issue more at the beginning of Chapter 3.

1.2.6. *Invasive Interfaces*

Boeckx (1999a; 1999b) proposes the concept of *invasive interfaces* as a means of eliminating interface levels in a theory using Multiple Spell-Out. The idea is that the external interface levels, LF and PF, act on the derivation cyclically when the derivation converges at one or both of the interface levels. In other words, the syntactic component does not hand pieces of the derivation over to PF and LF; PF and LF access them once they are convergent at their respective interfaces. I would like to extend this to mean that the interfaces can effect changes in the derivation in order to achieve convergence. For our purposes, if a derivation is not linearizable because it violates the LCA, PF acts *invasively* and triggers movement so that the derivation satisfies the LCA and is, thus, linearizable.⁴² Note that *invasive interfaces* does not simply equate PF movement to syntactic movement. Crucially, the syntactic component should have access only to formal features – not to the phonology. I adopt the notion of a p-signature (Hale and Keyser, 2003) and assume it to be visible to the syntax, much the same way formal features are. (See section 2.6 in Chapter 2 for more discussion.)

1.3. **Alternative Accounts of Linearization**

Before concluding this chapter, a word must be said about alternative theories of linearization. As we saw above, the overwhelming majority of the world's languages are either SVO or SOV. It comes as no surprise, then, that S-C-H order has also been proposed as the universal underlying order, from which SVO languages must be derived.

⁴² Boeckx conceives of Multiple Spell-Out as a copying operation. That is, phases are not handed over to PF and LF; they are copied and assigned an index. Boeckx discusses several intriguing implications of this view of Spell-Out for binding. Since the proposal here is compatible with either approach of Spell-Out (handing over or copying), I do not comment further here on the issue.

Such approaches do not rely on asymmetric c-command as the basis of linear order, but rather rely on other properties. I will review three such proposals. The first proposal takes S-C-H to be the universal underlying order, while the other two propose that the order of specifiers, heads and complements is set parametrically.

1.3.1. Fukui and Takano (1998)

Fukui and Takano (1998) propose a theory of linearization based on Bare Phrase Structure that postulates two operations in addition to Merge. Starting with the notion of Merge as a symmetric pair-wise operation that operates bottom-up, they propose a second operation, Demerge, that operates top-down. Demerge acts only on maximal projections. Finally, a third operation, Concatenate, linearizes elements as they are demerged.

Thus, starting with the root node, XP in example (51), Demerge acts on the specifier, YP, and demerges it from XP. X' is not available to Demerge, since it is not a maximal projection. Since only YP was demerged, Concatenate acts on it first and places it before the material of its sister, X', which has yet to be concatenated. In other words, Concatenate places YP at the left edge of the phonological output (represented by the open < bracket).

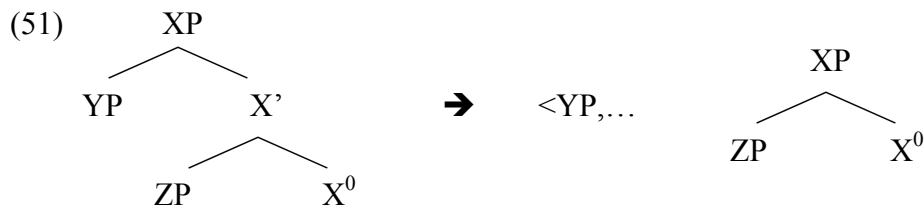

At the next level, Demerge acts on X' (now a maximal projection) and submits ZP to Concatenate. X⁰ is not available to Demerge, since it is not maximal projection. This is shown in the next example.

(52)

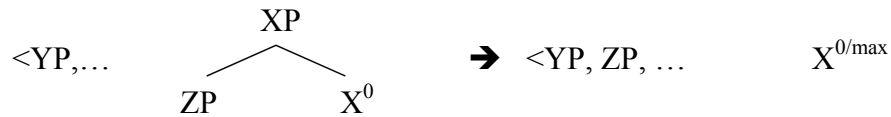

As the only element left, $X^{0/max}$, is concatenated after the rest of the derivation, resulting in the ordered sequence, $\langle YP, ZP, X^0 \rangle$. If YP and ZP are internally complex, Demerge and Concatenate will act on them in the same manner, until the derivation is completely linearized.

Under this approach, the X^0/XP complement asymmetry is not captured. Compare the derivation in (51) above with the one below.

(53)

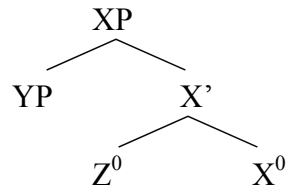

Under Fukui and Takano's approach, YP is demerged and concatenated first as above. Then, Z^0 is demerged and concatenated just as ZP is above. This is because Z^0 is a maximal category, in addition to being a minimal category. Thus, under Fukui and Takano's approach, there is no difference in how X^0 complements and XP complements are treated, and the asymmetry described above, that is the asymmetry with respect to bare noun complements versus phrasal nominal complements, is not captured.

1.3.2. Oishi (2003)

Oishi (2003) attempts to eliminate c-command from narrow syntax. He notes that only anaphora requires reference to c-command. Since anaphora resolution is not part of the computational component, there is no reason to assume that narrow syntax can refer to c-command. Assuming that it cannot, the only relations available are sisterhood and

dominance. Linear order is determined sequentially and counter-cyclically for each pair of sisters. Consider the hypothetical tree in (54). This phrase marker can also be represented as the set in (55), with the labels removed as shown. The aligning procedure operates in a top-down fashion. First, β and its sister are ordered, followed by the heads α and γ . This process is shown in example (56). Oishi suggests that the order $\langle \text{Spec, sister of Spec} \rangle$, or leftness of the specifier might be universal and reducible to EPP, although he does not elaborate on this point. This order must be kept separate from that of the head and the complement, which is determined parametrically.

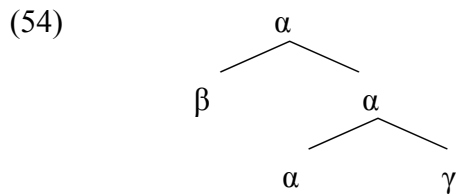

(55) $K = \{\{\alpha\}, \{\beta, \{\{\alpha\}, \{\alpha, \gamma\}\}\} = (\{\beta, \{\alpha, \gamma\}\}, \text{with labels removed})$

(56) *Aligning procedure*

- a. $\{\beta, \{\alpha, \gamma\}\}$
- b. $\langle \beta, \{\alpha, \gamma\} \rangle$
- c. $\langle \beta, \langle \alpha, \gamma \rangle \rangle$

Under this view, the mutually c-commanding heads do not present a problem, since c-command is irrelevant to the narrow syntax. Two heads which are merged together are linearized by the head parameter as stated above.

Aside from the stipulative quality of the ‘Spec Left’ condition, this approach suffers from many of the problems with the head parameter, described in section 1.1.2, that Antisymmetry sought to solve. Under the system proposed by Oishi, there are two possible orderings available for any XP in a given language, namely Spec-Head-

Complement and Spec-Complement-Head. Thus, each language must specify the head-complement order for each syntactic category.

Furthermore, Frank and Vijay-Shanker (2001) have argued that c-command is actually a primitive relation, and that the notion of dominance is derived from c-command.⁴³ Their argumentation rests partly on the following observations. Consider the two phrase markers in (57), which do not differ in any linguistically significant sense.

(57) *Hypothetical Phrase Markers*

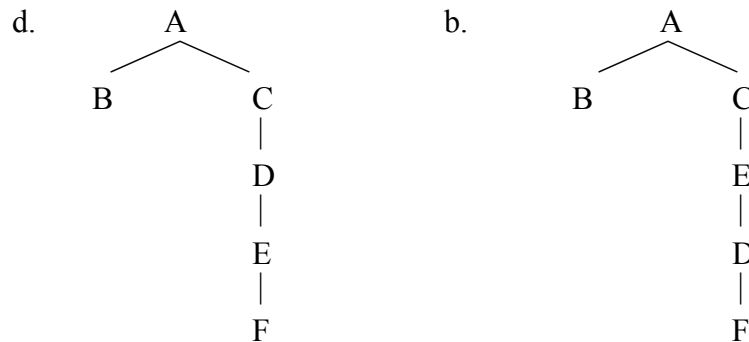

Frank and Vijay-Shanker (2001) observe that dominance relations distinguish between the two trees in (57), but that c-command does not. They offer this observation as support for their claim that c-command is a primitive relation. The validity of this argument rests on the assumption that a theory of grammar should be no more powerful than necessary: it should not be able to make distinctions that are not linguistically relevant. In this respect, c-command is more appropriate than simple dominance since dominance would treat the two trees above as distinct, even though there is no linguistic correlate for these trees.

⁴³ Frank and Vijay-Shanker do not actually provide a formal definition of c-command that does not appeal to dominance – an unfortunate shortcoming in their discussion. They do, however, derive dominance from c-command.

Given the problems associated with the head parameter and the need to retain the concept of c-command, perhaps as a primitive as suggested by Frank and Vijay-Shanker (2001), I do not adopt the proposal of Oishi (2003).

1.3.3. *Nakajima (1999)*

Nakajima (1999) develops a derivational approach to word order, in which linear order is determined as the derivation proceeds. He adopts Spec-Head-Compl as the base order, but uses a theoretical apparatus substantially different from the LCA. Instead, he appeals to the concepts of “label” and “adjunct” rather than to c-command to formulate his theory of linearization, shown in (57) (Nakajima, 1999: 64).

(58) **Derivational Linear Precedence Principle (DLPP)**

When Merge combines items α and β and creates a new term K, either α or β is the *leaf* of K, and the leaf precedes the other item in temporal order in K.

(59) **Leaf**

When Merge combines items α and β and creates a new term K, α is the leaf of K iff

- a. α is the label of K, OR
- b. α adjoins to K.

(60) **Adjunction**

When Merge combines items α and β and creates a new term K, α is the adjunct of K iff

- a. α does not become the label of K, AND
- b. β is an already projected term.

Like Kayne's LCA, these principles establish S-H-C as the base word order. The difference here is that two heads can exist in a configuration of mutual c-command and multiple left-adjunctions to the same functional projection are permitted. One of Nakajima's motivations for this approach is directly related to the initial merger problem. He notes that under any implementation of the LCA under Bare Phrase Structure, a head and its complement symmetrically c-command each other and cannot be linearized.⁴⁴ He argues that the LCA forces raising of one of two symmetrically c-commanding heads, and gives English verb phrases such as *see it* and *kick him* as evidence that raising is, in fact, not required and therefore that the LCA is not tenable. He adopts Chomsky's (1995) assumption that pronouns are bare D⁰ heads. There is strong evidence, however, that English pronouns are not simple heads, but rather XPs with internal structure (Déchaine and Wiltschko, 2002). Thus, the English examples that Nakajima offers do not provide clear evidence against the LCA.

1.3.4. Conclusion

This section has outlined various alternative approaches to linearization that do not rely on the LCA or on Kayne's notion of Antisymmetry. What these proposals all have in common is that they fail to predict the word order effects that arise when a head, as opposed to a phrase, appears in complement position. Here are the crucial structures again.

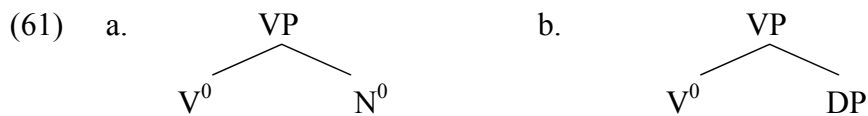

⁴⁴ This is not quite accurate. Under Uriagereka's (1999) approach, no point of symmetry arises between a head and a full XP complement. This approach is discussed in full detail in Chapter 2.

Although the verb and its complement c-command each other in both of these structures, only (61)a is in violation of the LCA, since in (61)b the verb asymmetrically c-commands the material inside the DP. The fact that these two structures are linearized differently calls for different treatments for them – a conclusion corroborated by the cross-linguistic data on noun incorporation. In the next chapter, I propose a theory of phrase structure that maintains the spirit of both Kayne’s Antisymmetry program and Bare Phrase Structure, and which is sensitive to the asymmetry in (61).

1.4. Conclusion

This chapter has very briefly discussed the approaches to phrase structure since 1957, focussing on X-bar Theory, Bare Phrase Structure and Antisymmetry. In the present work, I make the following assumptions. I adopt the theory of Bare Phrase Structure virtually unaltered Chomsky (1994). I also assume the basic ideas of Antisymmetry as proposed by Kayne (1994) and of Dynamic Antisymmetry as proposed by Moro (2000). However, as I have indicated, the implementation of these ideas must be modified in order to bring it into line with Bare Phrase Structure. This will be the business of Chapter 2. I have also discussed other proposals for linearization that depart from the basic assumptions of Antisymmetry. I have shown that these proposals fail to capture the different behaviour of heads and phrases when they appear in complement position. At the beginning of this chapter I showed that this difference consistently gives rise to word order differences. The theory of phrase structure proposed in the next chapter captures this fact about natural language.

2. Unifying Antisymmetry and Bare Phrase Structure

In this chapter, I discuss the challenges involved in unifying Antisymmetry and Bare Phrase Structure and develop a proposal that captures the advantages of both theories. There are two sets of problems in formulating a theory of phrase structure which retains the core properties of both Antisymmetry and Bare Phrase Structure. The first has to do with the theoretical framework in which Antisymmetry was developed. Kayne's original formulation does not translate into Bare Phrase Structure in a straightforward way. As will become clear, choices have to be made about how to reformulate the Linear Correspondence Axiom (LCA) under Bare Phrase Structure. We will consider various proposals for this as we proceed. The second problem deals with a particular aspect of Bare Phrase Structure that seems irreconcilable with Antisymmetry, namely the initial merger of two heads. When two heads are merged at the beginning of a derivation, they form a configuration of mutual c-command, in violation of the LCA. I refer to this as the Initial Merger Problem.

This chapter is organized as follows. In the first section, I review some previous attempts to bring Antisymmetry and Bare Phrase Structure to line with each other. In the second section, I discuss how the LCA can be restated within Bare Phrase Structure. In the third section, I discuss some of the immediate problems of combining the two approaches, specifically, the Initial Merger Problem. In the fourth section, I develop the core proposal of this discussion. The last section offers a summary and conclusion.

2.1. Previous Accounts

Chomsky (1995: 337) noticed the problem of mutually c-commanding heads (the Initial Merger Problem) early on, in his discussion of Romance clitics. As discussed in section 1.2.4, Chomsky suggested that the LCA is a PF constraint, and that violations of it can be tolerated in the syntactic component, as long as they are repaired before PF. The particular situation Chomsky was discussing involved Romance clitics, which are generally believed to raise to the IP domain (Kayne, 1989, 1991).⁴⁵ A typical scenario is shown in the Spanish example below, where the verb *quiero* ('I want') selects a bare D⁰ clitic *te* (2nd.sg). In (1), the verb and the clitic are in a mutual c-command relation, and thus cannot be linearized. Chomsky proposes that the clitic *te* raises to the IP domain and escapes symmetric c-command. Example (2) shows a typical analysis of leftward head-adjunction of the clitic to the verb, which was fairly standard at the time. However, under the framework being developed here, head movement is unavailable. We return to the subject of Romance clitics in section 2.5.1. The preceding discussion shows how the problem of the linearization of Romance clitics might be solved, but does not provide a general solution to the problem of the initial merger of two heads since the two heads undergoing initial merger will not always be a verb and a pronominal clitic.⁴⁶

⁴⁵ See Uriagereka (1995a; 1995b) for arguments for a functional projection, FP, which hosts clitics in western Romance. There is also a large literature that suggests that pronominal clitics in Romance are base-generated in their surface position (Burzio, 1986; Jaeggli, 1986; Roberge, 1990; Strozer, 1976).

⁴⁶ Note that the facts are not as simple as they're made out to be here. There are different kinds of pronouns in Romance, some of which behave as clitics as mentioned here, others of which can function independently. Both kinds have different distributions. A full-scale study of the linearization of pronominal elements in Romance is beyond the scope of this thesis. See Moro (2000) for discussion.

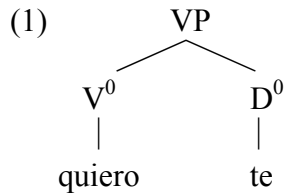

‘I love you.’

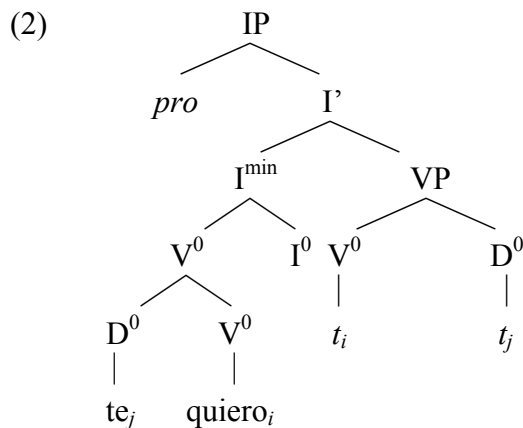

We now turn to three specific accounts of Antisymmetry within a Bare Phrase Structure framework. The first is that of Guimarães (2000), which looks specifically at the Initial Merger Problem. Guimarães’ solution is to admit unary branching (i.e., non-branching structures) in order to avoid LCA violations. The second is that of Nunes and Uriagereka (2000). Nunes and Uriagereka do not discuss the Initial Merger Problem, as their goal is to account for CED effects. Finally, Richards’ (2001) proposal, which I essentially adopt here, reformulates the LCA so that it retains Bare Phrase Structure, but with fewer problems than Nunes and Uriagereka’s proposal has.

2.1.1. Guimarães (2000)

Guimarães (2000) acknowledges the paradox described in the first chapter concerning the apparent incompatibility of Bare Phrase Structure and Antisymmetry. His solution is to allow for non-branching or vacuous projections in order to avoid symmetric c-command. He suggests that vacuous projections are fully compatible with Bare Phrase Structure,

thus allowing the computational component to retain the essence of that theory, while still satisfying Antisymmetry. The argument proceeds as follows.

Guimarães acknowledges that the operation Merge is defined as taking two objects, α and β , and placing them in a single complex structure, K , with label γ such that $K = \{\gamma, \{\alpha, \beta\}\}$. But nothing in this definition precludes the possibility that α and β are identical. In other words, an element, α , can merge with itself (Self-Merge⁴⁷). Guimarães exploits this point in the development of his argument. He asserts, in fact, that in the absence of empirical evidence to the contrary, to assume that an element cannot merge with itself is an unmotivated stipulation. Once an element has self-merged, the following set emerges: $K = \{\gamma, \{\alpha, \alpha\}\}$. He notes that the set $\{\alpha, \alpha\}$ is identical to the set $\{\alpha\}$, following the Extensionality Axiom of Set Theory (Partee *et al.*, 1993).⁴⁸ Consequently, when α merges with itself, it forms the set $K = \{\gamma, \{\alpha\}\}$. The following example illustrates Self-Merge with a hypothetical verb selecting a bare noun. In this case, the noun has undergone Self-Merge.

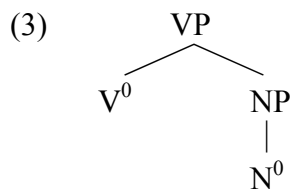

In order to prevent Self-Merge from taking place all over the derivation, Guimarães assumes, following Collins (1997) and Chomsky (2000), that Merge is costly.⁴⁹ Thus, Self-Merge (and Merge in general) can take place only when required by the derivation. Since Self-Merge is required only to ensure that the LCA can linearize

⁴⁷ Note that Self-Merge is just a label of convenience. The term does not refer to an operation distinct from Merge.

⁴⁸ This axiom states that if a given element appears more than once in the same set, then this set is equivalent to an otherwise identical set in which the element in question appears only once.

⁴⁹ Recently, however, Chomsky (2005a) assumes that not only is Merge free, but that Move is free, too.

that part of the derivation created by the initial merger of two heads, it is predicted that it will take place only in this situation, that is, only at the very beginning of the derivation, when two heads would otherwise be merged (although see the discussion below).

Note that this approach requires look-ahead power. The approach Guimarães' follows, and which I adopt later, is that of *invasive interfaces* (Boeckx, 1999b). Invasive interfaces can 'look down' into the derivation and effect changes to satisfy constraints at that interface. Thus, as the LCA is a PF constraint, PF can effect changes at an earlier stage of the derivation so that when the derivation reaches PF, it does not violate LCA (or any other PF constraint). Invasive interfaces, then, are the antithesis of Procrastinate (Chomsky, 1993). Although I adopt Boeckx's view on invasive interfaces, I show below that Guimarães' implementation of it is problematic.

This analysis is problematic in several regards. First, Guimarães assumes that the LCA is a PF phenomenon and, as just noted, invokes invasive interfaces to explain this fact. I see two problems here. On the one hand, PF would have to look back not just to the narrow syntax, but to a stage before the narrow syntax, that is before the process of merging items from the Numeration. In other words, the syntactic component would have to know that the merger of two heads would violate the LCA before Merge even takes place. On the other hand, if the LCA is not computed until PF, violations of it should be tolerable in the narrow syntax, as long as they are taken care of promptly (i.e., before PF). Under Guimarães' analysis, violations of the LCA are not tolerated at all in the narrow syntax, effectively making the LCA a syntactic rather than PF constraint. This view effectively eliminates the difference between syntactic and PF constraints.

Consider the following scenario. Constraint A is active only at PF, not in the narrow syntax. If we assume invasive interfaces, then constraint A must be satisfied at PF. Violations of constraint A are tolerated in the narrow syntax, as long as they are repaired promptly, as dictated by invasive interfaces. Now consider the same scenario, except that Constraint A is active at both PF and in the narrow syntax. Here, violations of constraint A are not permitted either at PF or in the narrow syntax. Under Guimarães' view of the LCA, violations are not tolerated at any level of grammar, effectively making it a syntactic rather than a PF constraint. If PF constraints work as Guimarães proposes for the LCA, then there is no empirical difference between PF constraints and more general constraints. If we do not wish to eliminate the possibility of properly PF constraints in UG, we cannot accept Guimarães' view of invasive constraints.

Second, it is unclear how Merge works in Guimarães' proposal. At the beginning of the derivation, Merge must select two lexical items from the Numeration. When a lexical item is selected, either it is removed from the Numeration, or its index is reduced by one. Recall that the derivation cannot converge if material remains in the Numeration. Under Guimarães' proposal, applications of self-Merge would have to somehow know to reduce the index of the lexical item in question only once, thus making self-Merge a distinct operation from ordinary Merge, or during the formation of the Numeration, the system would have to have the foresight to know which lexical items will undergo self-Merge, so as to include them twice in the Numeration. Otherwise, the whole concept of the Numeration will have to be re-thought.

Finally, there is another situation in which two heads appear in a situation of symmetric c-command other than at the start of the derivation. Consider the following hypothetical structure. Note that the specifier of XP is a head, Z^0 .

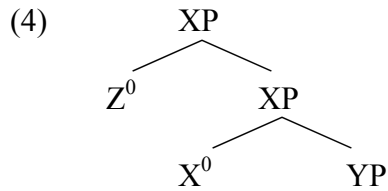

Now, if another head, W^0 , merges with XP, then W^0 and Z^0 will c-command each other. To avoid the situation, W^0 would have to undergo Self-Merge before undergoing Merge with XP, resulting in the structure in (5).

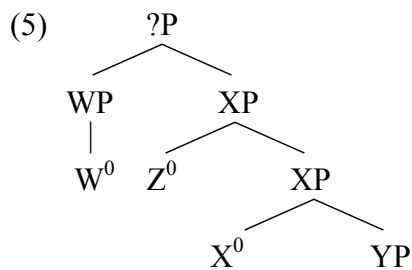

It is unclear exactly what the status of this structure is, since two maximal projections have undergone Merge. It does appear, though, that XP cannot be the complement of W^0 , at least under the usual definition of complement. Normally, when two maximal projections undergo Merge, one is the specifier of the other, but XP already has a specifier here. Another option, of course, is Moro's analysis of small clauses, but it seems strange that small clause formation is triggered by a clitic appearing in the specifier of one of the XPs. Since Z^0 is causing the problem, a solution along the lines of what Guimarães proposes would involve Self-Merge of Z^0 . However, this would require even more look-ahead power than described above. Z^0 would have to know that the XP it is going to

become a specifier of W^0 will itself eventually merge with another head, W^0 here, that has phonological content.

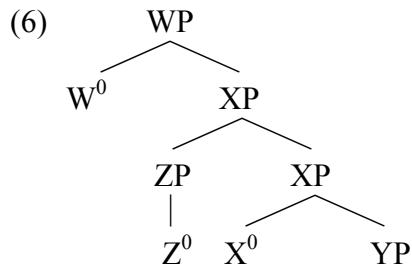

Having dispensed with Guimarães' attempt to unite Bare Phrase Structure with Antisymmetry, we now turn to an attempt by Nunes and Uriagereka to account for CED effects with the LCA within Bare Phrase Structure.

2.1.2. *Nunes and Uriagereka (2000)*

Nunes and Uriagereka (2000) explore CED effects (Huang, 1982) within the context of Multiple Spell-Out (Multiple Spell-Out). They note the incompatibility of the LCA and Bare Phrase Structure and propose the following reformulation of the LCA.

- (7) LCA = A lexical item α precedes a lexical item β iff α asymmetrically c-commands β . (Nunes and Uriagereka, 2000: 23)

The crucial difference between the version of the LCA in example (7) and the original version in Kayne (1994) is that the LCA in (7) applies to heads rather than to categories. This change has several empirical consequences, to be discussed in detail in section 2.2. I delay the discussion of consequences of Nunes and Uriagereka's proposal until 2.2 as their discussion sets the stage for my proposal.

2.1.3. *Richards (2001)*

Richards (2001) assumes that the LCA is evaluated over all nodes in the tree, in contrast to Kayne's original proposal, where the LCA was evaluated among all non-terminal nodes (and Nunes and Uriagereka's proposal, where the LCA is evaluated over all terminal nodes, or heads).⁵⁰ Richards' assumptions about linearization are as follows (Richards, 2001: 2):

Spell-Out considers the set A of pairs of asymmetrically c-commanding XPs and X^0 s in the tree which the syntax gives it, and generates from this a set of instructions for linearization; if $\langle \alpha, \beta \rangle$ is in A , then the *image* of α (that is, the terminals dominated by α) precedes the image of β .

Again, this has significant empirical consequences that we outline in section 2.2.

2.1.4. Conclusion

In the previous two sections, we considered three possible ways to solve the problem of mutually c-commanding heads. Guimarães (2000) proposed to permit vacuous projections in phrase structure, essentially modifying Bare Phrase Structure and leaving Antisymmetry untouched. We have seen, however, that this move is unsatisfactory in several regards. I also very briefly introduced the core difference between Nunes and Uriagereka's proposal on the one hand and Richards' proposal on the other. The difference is that Nunes and Uriagereka consider only heads for the purposes of linearization, whereas Richards considers all nodes in the tree for linearization. The details will be spelled out in the forthcoming sections. Ultimately, my proposal falls in line with that of Richards rather than Nunes and Uriagereka.

⁵⁰ The thesis of Richards' paper is that syntax places a linearization constraint on structure such that two projections of the same categorial type cannot appear structurally adjacent to each other, giving rise to an OCP effect.

2.2. The LCA and Bare Phrase Structure

There have been several attempts to recast the LCA within Bare Phrase Structure, given that the LCA was originally formulated with X-bar theory in mind (Epstein *et al.*, 1998; Guimarães, 2000; Nunes and Uriagereka, 2000; Oishi, 2003; Richards, 2001; Uriagereka, 1999). I discuss here Kayne's original formulation of the LCA within the context of Bare Phrase Structure. First, it is clear that the structure in example (32) from section 1.2.4, repeated here as example (8), is not a valid phrase marker in Bare Phrase Structure, since that theory makes no inherent distinction between a minimal projection and a terminal. In other words, we do not distinguish C from *c*, for example.⁵¹

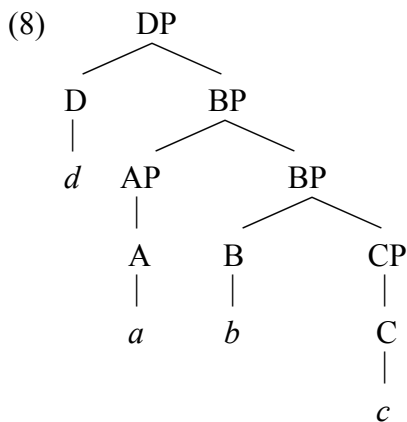

Instead, let us consider the phrase marker in (9), where we assume, for now, that AP and CP have internal structure.

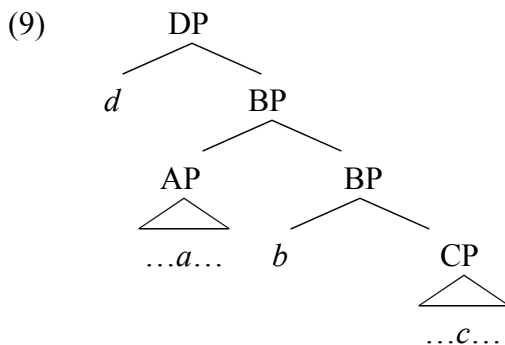

⁵¹ Note that (8) is also invalid in a Bare Phrase Structure framework due to the presence of non-branching nodes.

If we define A in terms of non-terminals (that is, where A consists of a set of ordered pairs $\langle \alpha, \beta \rangle$, α and β non-terminals, and α asymmetrically c-commands β) we run into serious problems very quickly. In (9), AP asymmetrically c-commands CP, but BP does not enter into a c-command relation with anything.⁵² Thus, the only ordering of non-terminals is $\{\langle \text{AP}, \text{CP} \rangle\}$, which gives rise to the non-total ordering $\{\langle a, c \rangle\}$. Furthermore, if another head is merged with DP, as in (10), no new orderings are computable.

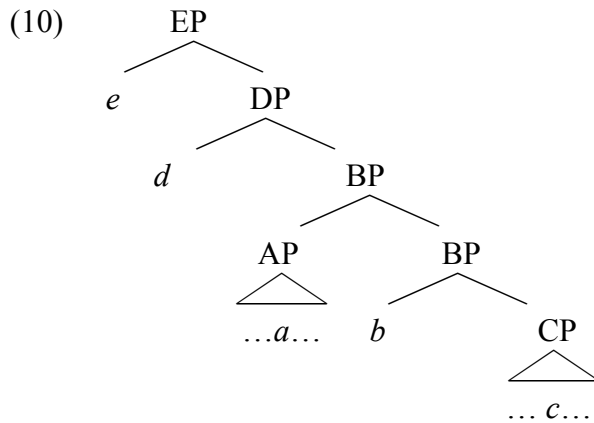

Since a formulation of the LCA in terms of non-terminals does not result in a usable system, that is, it does not give a total ordering of heads, we must consider other possibilities. The LCA can be reformulated in terms of terminals, or heads, which is the approach taken by Uriagereka (1999) and Nunes and Uriagereka (2000). There is another logical possibility, in which the LCA is reformulated in terms of all nodes in the tree (Richards, 2001).⁵³ We will consider both of these approaches, and, in the end, I will adopt the all-nodes approach of Richards (2001).

⁵² Recall that for Kayne (1994), c-command is a relation that holds only among non-terminals, not among the lexical heads themselves.

⁵³ As far as I know, (Richards, 2001) is the only work that pursues the all-nodes approach.

We consider first a reformulation of the LCA in which A is determined by the set of **all** nodes in the tree, and $d(A)$ is reformulated accordingly.

(11) A = the set of ordered pairs c such that X and Y are *nodes* in the syntactic tree and X asymmetrically c -commands Y

(12) $d(A)$ is the mapping from A to the set of ordered heads $\{ \langle x, y \rangle \}$, such that x is dominated by X and y is dominated by Y .

Note, however, that Kayne's (1994) definition of c -command, repeated in (13), cannot be used here, since it was defined for categories (XPs) only.

(13) X c -commands Y iff X and Y are categories and X excludes Y and every category that dominates X dominates Y . (Kayne, 1994: 18).

We therefore adopt the revised definition for c -command in (14), which does not limit the relation to XPs, but rather is defined for all nodes in the tree.

(14) x c -commands y iff x excludes y and every category that dominates x dominates y .

If we reconsider the tree in (10), we get the following results for A and $d(A)$, where $d(A)$ reduces to the linear order $\langle e, d, a, b, c \rangle$. This gives us the desired results, namely a total, irreflexive, non-contradictory ordering of the terminals of the phrase marker.

(15) $A = \{ (e, d), (e, BP), (e, AP), (e, a), (e, b), (e, CP), (e, c), (d, a), (d, b), (d, CP), (d, c), (AP, b), (AP, CP), (AP, c), (b, c) \}$

(16) $d(A) = \{ (e, d), (e, a), (e, b), (e, c), (d, a), (d, b), (d, c), (a, b), (a, c), (b, c) \}$

We now turn to the other logical possibility in which A is defined solely in terms of heads. First, note that stating the LCA in terms of heads alone has a certain appeal since it reduces the number of ordered pairs that must be considered. Also, PF must

ultimately produce a linear order of heads, not phrases; it therefore seems reasonable to state the LCA in terms of heads. Consider the following definition for the set A .

- (17) A is the set $\{\langle X, Y \rangle\}$ of all ordered pairs of heads such that X asymmetrically c -commands Y .

Let us now consider a simpler version of example (9), without any specifiers. This is shown in (18).

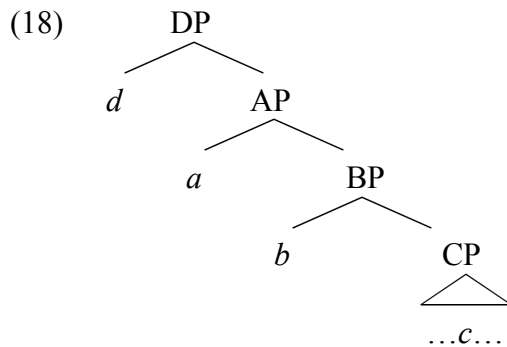

Under this definition of the LCA, the set A consists of the following set of ordered pairs $\{\langle d, a \rangle, \langle d, b \rangle, \langle d, c \rangle, \langle a, b \rangle, \langle a, c \rangle, \langle b, c \rangle\}$, which give the linear order $\langle d, a, b, c \rangle$.

Under this approach, then, there is no need to make reference to the image of A , $d(A)$.

The LCA can therefore be re-stated as in (19), which is essentially Nunes and Uriagereka's (2000) definition for the LCA.

- (19) A is a linear ordering of T , where T is the set of all heads.

Let us now turn to complex specifiers, as in (20). We consider atomic specifiers (specifiers consisting only of a head) later in section 2.4.

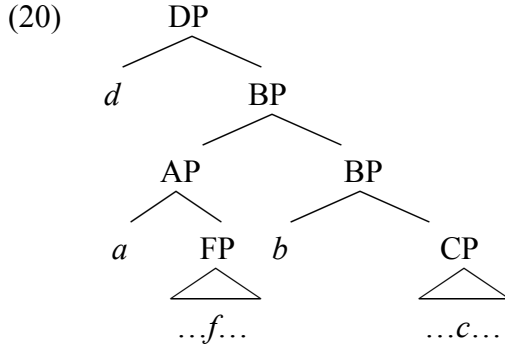

The structure of AP itself is identical to that of BP in (18) above. The linearization of AP thus occurs in the same manner, giving the order $\langle a, f \rangle$. There is, however, no c-command relation between either of the heads a and f inside AP and any of the other heads in the phrase structure below the specifier position (i.e., b or lower). This is because nothing inside the specifier can c-command out of the specifier, since only heads can enter into a c-command relation. Thus, linear order cannot be established between the heads a and f of AP, and the rest of the structure. Although d asymmetrically c-commands the material inside AP, this is not sufficient to allow for a total ordering. Based on the mechanism developed so far, the set A for the structure in (20) would appear as in (21), which would then reduce to the six possible orderings shown in (22). Since A does not give rise to a total, irreflexive, non-contradictory ordering, the phrase structure in (20) cannot be linearized, and the derivation crashes at the PF interface.

$$(21) \quad A = \{ \langle d, a \rangle, \langle d, f \rangle, \langle d, b \rangle, \langle d, c \rangle, \langle a, f \rangle, \langle b, c \rangle \}$$

$$(22) \quad \langle dafbc \rangle \langle dabfc \rangle \langle dabc f \rangle \langle dbac f \rangle \langle dbcaf \rangle \langle dbafc \rangle$$

Uriagereka (1999) recognizes this problem and proposes that complex XPs must undergo Spell-Out before merging into the specifier position of another phrase. Thus, the derivation must permit Multiple Spell-Out, with Spell-Out taking place each time a complex XP is merged into specifier position. Thus, the phrase marker in example (20),

with the outlined typeface representing material that has been spelled-out, will have the structure in (23) by the time *d* is merged with BP.

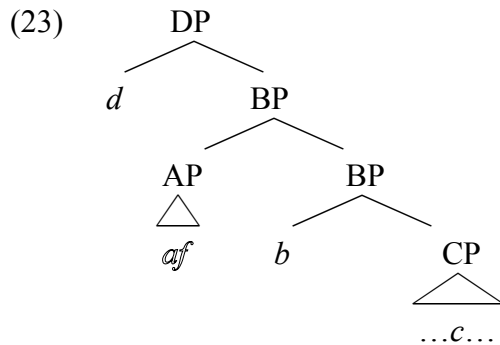

At this point, Uriagereka does not decide how AP is linearized with the rest of the structure. He offers two choices. Either AP is somehow linearized before *b* and after *d*, as the phrase marker suggests, or the linearization of the Spellee⁵⁴ with respect to the rest of the derivation is not handled by syntax, but rather by the performance system. Uriagereka pursues the latter option, but does not give a definitive account.⁵⁵

Multiple Spell-Out has empirical consequences as discussed by Uriagereka (1999), Nunes and Hornstein (2000) and Nunes (2004). They argue that it captures CED effects (Huang, 1982) as shown in the pair of sentences in (24). The explanation goes as follows. The DP [a picture of who] is the complement of the verb in (24)a. When *wh*-movement takes place, this DP has not yet been Spelled Out since it is not in a specifier position. Thus the *wh*-phrase *who* is free to raise. In (24)b, in contrast, the DP [a picture of who] is a derived subject in SpecTP. Before the DP moves into specifier position it undergoes Spell-Out. The Spellee, DP = {a, <a, picture, of, who>}, is then effectively frozen for further operations (but see below).

⁵⁴ This term is due to Arsalan Kahnemuyipour.

⁵⁵ It might also be that the label of the spelled-out XP is used for linearization. Since the approach that I eventually adopt does not face the problem of having to spell-out complex specifiers for the purposes of linearization, I have not worked out this proposal.

(24) *CED Effects in English*

- a. Who_{*i*} did Ashleigh take a picture of *t_i*?
- b. *Who_{*i*} was [a picture of *t_i*]_{*j*} taken *t_j*?

Assuming Multiple Spell-Out, as argued by Uriagereka (1999), Nunes and Uriagereka (2000), and Nunes (2004), accounts nicely for CED effects. Following Cinque (1999), adjuncts (such as adverb phrases) are taken to be specifiers of separate functional projections in the main structure of the clause. Thus, this approach classifies adjuncts and specifiers together and predicts that they block extraction. This requires, of course, that *A* be defined for the purposes of the LCA as in (17) above; that is, in terms only of heads. If *A* is defined in terms of all nodes as in (11) above, the CED effects are not captured because complex specifiers can be linearized with the rest of the structure and thus need not be spelled out when they merge.

We see that the formulation of *A* in terms of heads alone, aside from being theoretically more motivated, appears to account elegantly for CED effects. However, the account proves to be overly simplistic as follows: Under this approach, extraction from a specifier should never be permitted. This clearly cannot be the case however if we consider the following data.⁵⁶

(25) *Extraction from a Specifier*

- a. Which room did John talk to his brother in *t*?
- b. Who did John talk to *t* in the kitchen?

Both sentences in (25) are grammatical. Let us investigate standard proposals on these structures in light of Nunes and Uriagereka's approach. Under an analysis that assumes

⁵⁶ Another approach to these adjuncts which is commonly (and tacitly) assumed is that they are not subject to the LCA and are right-adjoined in the traditional manner. Under Nunes and Uriagereka's approach, such adjuncts are still not linearizable with the rest of the structure, so the following discussion still holds.

that the locative PP is in the specifier of a functional projection, such as Cinque (1999), we would predict that the first sentence is ungrammatical, while the second sentence is grammatical, contrary to fact since both are grammatical. Consider the structure in (26), in which the locative PP appears in the specifier of a LocP, along the lines of Cinque (1999).⁵⁷

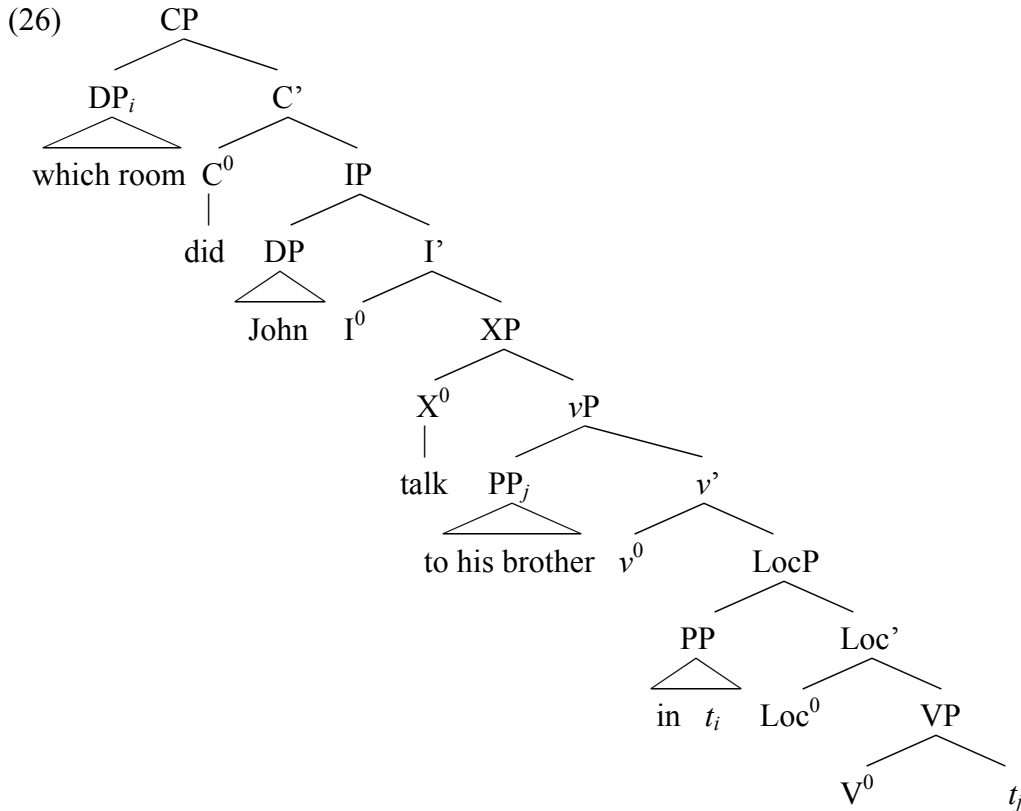

In this structure, both the locative PP and the direct object appear in specifier projections, and thus are required to undergo Multiple Spell-Out, and will be unavailable for subextraction. The entire object DP, however, is still available for further movement.

On the other hand, if we adopt a Larsonian VP shell for structures such as these, the adjunct is the complement of the lower V⁰ head. Now, we predict that the first

⁵⁷ Note that I have followed a traditional analysis that uses head movement since a remnant movement account of these facts is beyond the scope of this thesis. Also, I have shown overt movement of the PP complement to a Case checking position and subsequent raising of the verb to a higher position (Koizumi, 1995; Lasnik, 1995).

sentence is grammatical and that the second sentence is ungrammatical, again contrary to fact. Consider this time the structure in (27).

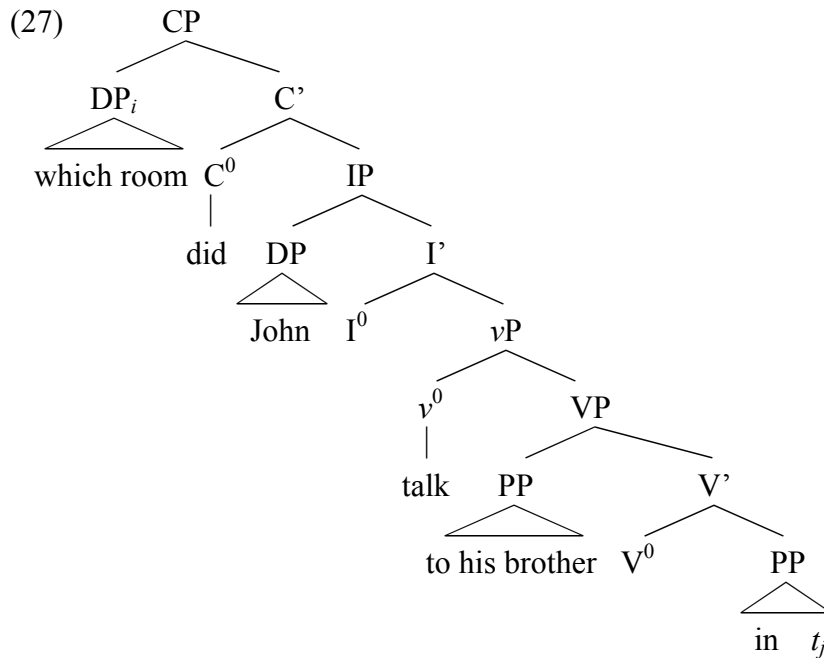

Here, the locative PP can be freely extracted from since it is not a specifier; however, the complement PP, *to his brother*, which is in a specifier position, is not available for subextraction, contrary to fact. Curiously, if the locative PP is absent, then subextraction from the complement PP is predicted to be grammatical, since it would then appear in a complement position, rather than in a specifier.

Even if we explain away this conundrum, the Multiple Spell-Out approach outlined above predicts the existence of a language that differs in the extraction possibilities of the object depending on the presence or absence of VP level adjuncts in the clause as discussed for (27) above. So far as I know, no such language exists. Thus, under any view of the structure of clauses with locative PP adjuncts, Nunes and Uriagereka's approach is untenable.

Stepanov (2001a; 2001b) argues that CED effects are not a unitary phenomenon. Instead, he argues that the impossibility of extracting from subjects and from adjuncts requires two different explanations. Part of the empirical support for this approach is that there is a great deal of cross-linguistic variation with respect to extraction from subjects, while extraction from a certain set of adjuncts is by and large uniformly disallowed in natural language.⁵⁸ Stepanov argues that the impossibility of extracting from subjects in English is due to the fact that subjects are moved constituents (see below for details). Stepanov also argues that adjuncts are added to the derivation post-cyclically. By the time the adjunct is added post-cyclically, it is too late for one of its sub-constituents to be extracted and raised to the specifier of a higher probe. By then, the probe and goal are in separate phases.

What I would like to concentrate on here is the impossibility of extracting from subjects. As Stepanov points out, there is a great deal of cross-linguistic variation here. The generalization that he makes is that extraction is possible from subjects only in those languages where the subject remains *in situ*. This can actually be seen quite clearly in English with existential constructions (Stepanov, 2001a ex(15) p. 79).

(28) *Extraction from Subjects in Existential Constructions in English*

- a. *Who_j did [a picture of t_j]_i [_{VP} t_i hang on the wall]?
- b. Who_j was there [_{SC} [a picture of t_j] on the wall]?

While the extraction of *who* in (28)a is, as expected, impossible, the extraction of *who* in (28)b is well-formed. In (28)b, the subject has not raised from its predicate-internal position, and remains *in situ*. These data support Stepanov's claim that extraction out of

⁵⁸ This set of adjuncts includes clausal adjuncts such as, *while Peter washed the dishes*. Thus, the following sentence is ungrammatical:

- i. *What did Mary read the newspaper while Peter washed *t*?

a moved constituent is barred. This makes an interesting prediction about extraction from the subjects of stage- and individual-level predicates. Kratzer (1995) argues that subjects of individual-level predicates are merged in the IP domain, not predicate-internally. If Stepanov's proposal is correct, extraction from the subject of an individual-level predicate should be possible in principle, although other factors might result in degraded judgments. The data in (29) support Stepanov's proposal.⁵⁹

(29) *Extraction out of Subjects of Individual-Level Predicates*

- a. Who would naked pictures of be funny to look at?
- b. Which continent are the animals on generally quite ferocious?
- c. The people from that city are cold.
- d. Which city are the people from cold?

In (29)a and b, the subject has been extracted from with individual-level predicates. The predicate in (29)c is ambiguous between a stage-level reading (where "cold" refers to body temperature) and an individual-level reading (where "cold" refers to temperament, and means roughly "unfeeling"). However, once the subject is extracted from as in (29)d, only the individual-level reading is available.

Stepanov accounts for these facts as follows. Assuming the copy theory of movement, PF must delete lower identical copies of moved constituents. Stepanov also

⁵⁹ The judgments aren't as clear cut as one would hope. Many examples are significantly degraded, although still not as ungrammatical as the stage-level counterparts.

- i. ?What are books about interesting?
- ii. ?*What is a book about interesting?
- iii. *What is a book about on the table?
- iv. What is there a book about on the table?

I am not sure what accounts for the degraded status of i. and ii., perhaps the type of DP plays a role; however, the generalization still holds that extraction from subjects of individual-level predicates is preferable to extraction from subjects of stage-level predicates. See Moro

assumes an operation, *Scan*, which evaluates chains for identity at PF. Extracting an element from a moved constituent destroys the identity relation in the original movement, as shown below.

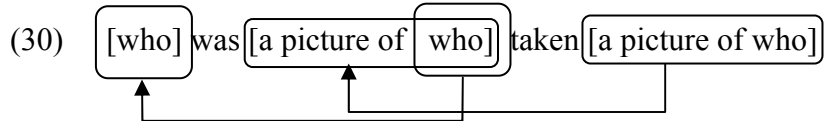

In (30), Stepanov argues that deletion under identity at PF can happen in either of two orders: first the lower copy of a *picture of who* can delete, then the lower copy of *who* can delete ((31) and (32), respectively).

(31) [who] was [a picture of who] taken [~~a picture of who~~]

(32) [who] was [a picture of ~~who~~] taken [~~a picture of who~~]

Alternatively, the lower copy of *who* can delete first, but then we run into a problem, because the lower copy of a *picture of who* is now distinct from the higher copy, which is now, a *picture of who*. Stepanov argues that the operation *Scan* takes place all at once. Under this view, Stepanov claims, *Scan* is unable to evaluate the identity or lack thereof of the two copies of a *picture of who* because the two copies are at once identical and non-identical, pending deletion of *who* in the higher copy.

There is a problem with this approach, however, with respect to chain formation at PF for deletion purposes. Consider again the input to PF before deletion. *Who* actually forms a three-member chain. It is true that one of the chains is part of a larger chain since the lower two instances of *who* are located inside links of the chain formed by the two instances of a *picture of who*, but if we assume that *Scan* looks through the derivation for identical copies, it will find all three copies of *who* and mark the lower two for deletion.

(33) [who] was [a picture of ~~who~~] taken [a picture of ~~who~~]

There is no problem, then, in forming a chain from the two instance of *a picture of ~~who~~*, since the two copies are now identical. There is, of course, no problem if Scan evaluates the chain for *a picture of who* first, as described above. Thus, it does not in fact matter which chain is evaluated first. The output is the same in both cases, and this sentence is incorrectly predicted to be grammatical. The next section proposes an alternative to Stepanov's proposal, which builds on his original observations.

2.2.1. *Object Shift and Extraction*

What, then, is the explanation for CED effects? Stepanov's observation that the lack of extractability from subjects correlates with the fact that they have undergone overt movement is an important one. However, it remains to be seen if extraction is impossible from all moved phrases. To answer this, we will look at extraction from objects in English and from shifted objects in Romanian. Note, however, that an account of extraction out of subjects is not offered here, but the phenomenon is instrumental in choosing between the two versions of Antisymmetry being considered here – namely, that of Richards (2001) and that of Nunes and Uriagereka (2000). Consider first the following English paradigm.

- (34) *Extraction from DPs in English*⁶⁰
- a. What did John steal a book about from the library?
 - b. [?]What was there a book about stolen from the library?
 - c. *What was a book about stolen from the library?

⁶⁰ I have checked these data with several native speakers of English. Not all speakers are in full agreement with the judgements given here. However, all speakers agree that (34)a is better than (34)b and that (34)b is better than (34)c. See Moro (1997) for a discussion of these types of sentences that is compatible with Dynamic Antisymmetry.

Legate (2003) argues that passives (and unaccusatives) contain an inner (ν P) and outer (CP) phase just as transitives and unergatives do. Furthermore, passives must contain an intermediate landing site, based on *there*-insertion, quantifier float and reconstruction effects.

(35) *Intermediate Landing Site for Passives*

- a. There was [a book about linguistics]_i stolen t_i from the library.
- b. [The linguistics books]_j were [_{QP} all t_j]_i stolen t_i from the library.

Nevertheless extraction from a *there*-passive such as (34)b is only slightly degraded, if at all, in contrast to extraction from a standard passive (34)c.⁶¹ Both of these DPs have undergone movement, although only extraction from the standard passive leads to full ungrammaticality. The difference between these two sentences is that the DP in question in (34)b has arguably remained inside the lower phase, while the DP in (34)c has moved across a phase boundary. Thus, we conjecture that it is movement across the ν P phase boundary that gives rise to the CED violation.

Next, we show that object shift takes place in Romanian within the ν P phase and that extraction is possible out of these shifted objects. Much of this discussion is based on Alboiu (2000). Romanian is a VSO language in which both subject and object remain in situ in neutral discourse environments. Alboiu shows that VOS order results from the object raising over the subject rather than from rightward movement of the subject.^{62,63}

⁶¹ The degraded status of extraction from the existential construction is probably due to the information structure of these constructions. The associate of the expletive is usually new information, so it would normally be unavailable for *wh*-extraction. However, the context of a raised echo question improves the judgement:

- A- There was a book about otorhinolaryngology stolen from the library.
- B- What was there a book about stolen from the library???

⁶² Alboiu employs a variety of tests including binding, quantifier raising and quantifier float.

⁶³ This discussion must assume that the base position of the subject is inside the lower phase and, crucially, that the object landing site is also inside the lower phase. There are several accounts of a split ν P layer

With this in mind, consider the following examples of *wh*-extraction in Romanian (Alboiu, pc).

(36) *Wh-Extraction from Shifted Objects in Romanian*

- a. [Despre cine]_i a scriș Ion [o carte t_i]?
 about who has written John a book
 ‘Who did John write a book about?’
- b. [Despre cine]_i a scriș [o carte t_i]_j Ion t_j?
 about who has written a book John
 ‘Who did John write a book about?’

We see that extraction is possible from the object in both VSO and VOS word orders. If Alboiu is correct in claiming that VOS word order arises from object movement, we must conclude again that extraction from a moved constituent is possible.⁶⁴

It is not the goal of the present work to give an account of CED effects. Rather, the purpose of this section is simply to show that extraction is sometimes possible from a specifier – a fact that supports the proposal of Richards (2001) but not that of Nunes and Uriagereka (2000) since Nunes and Uriagereka (2000) expressly prohibit extraction from a specifier. One might, however, proceed along the following lines. Suppose that movement is permitted out of a moved constituent, as long as that constituent has not crossed a phase boundary. Following Fox and Pesetsky (2005), we assume that Linearization takes place *near* the end of the Spell-Out of each phase. If an XP moves out

(Basilico, 1995; Bowers, 2002; Tanaka, 1997; Travis, 1991), which, coupled with McGinnis’ (2003) view that the left edge of the lower phase is variable, could lead to an explanation of these facts along the lines outlined here. Since explaining CED effects is not the goal of this dissertation, I leave a fuller discussion of the matter to future research.

⁶⁴ One might argue here that *despre cine* (‘about whom’) is a VP-adjunct and not a nominal complement. The following data show that *o carte despre X* (‘a book about X’) is a constituent:

- i. O carte despre Matt Damon a scriș (pina) si Ion.
 a book about Matt Damon has written (even) and John
 ‘Even John has written a book about Matt Damon.’

In this example, the object *o carte despre Matt Damon* has been topicalized. This sentence is an appropriate continuation to a statement such as, “Everyone’s written a book about Matt Damon these days...”

of a phase, its internal constituents are linearized before that phase is closed off. Once it has been linearized, no further operations may alter that linear order. This is schematized in the following example.

(37) *Blocking of Extraction by Phase-Level Linearization*

- a. $[_{XP} X^0 \dots [_{YP} Y^0]]$ – formation of complex XP
- b. $[_{vP} [_{XP} X^0 \dots [_{YP} Y^0]]_i v^0 \dots t_i]$ – movement of XP to phase-edge
- c. $\langle X^0, Y^0, v^0 \rangle$ - Linearization (followed by Spell-Out)
- d. $[_{IP} [_{XP} X^0 \dots [_{YP} Y^0]]_i I^0 [_{vP} t_i v^0 \dots t_i]$ – movement of XP
- e. $*[_{CP} [_{YP} Y^0]_j [_{IP} [_{XP} X^0 \dots t_j]_i I^0 [_{vP} t_i v^0 \dots t_i]$ – extraction from XP
- f. $\langle Y^0, X^0, I^0, v^0 \rangle$ - contradictory order (cf. c.) – derivation crashes

Let us now apply this to the cases of subject extraction in English. The subject is merged in Spec vP , just as the lower phase is being closed off. At this point, linearization takes place, followed by Spell-Out. The subject then raises to Spec TP . At this point, the order of the lexical items in the subject DP has already been specified, so no further operations can change that order. These steps are illustrated below.

(38) *CED effects in English Subjects*

- a. $[_{vP} [_{DP} A \text{ picture of } [_{DP} \text{who}]] [_{VP} \text{hang on the wall}]]$
- b. Linearize and Spell-Out: $\langle a, \text{picture}, \text{of}, \text{who}, \text{hang}, \text{on}, \text{the}, \text{wall} \rangle$
- c. $[_{IP} [_{DP} A \text{ picture of } [_{DP} \text{who}]] \text{did } [_{vP} [_{DP} A \text{ picture of } [_{DP} \text{who}]] [_{VP} \text{hang on the wall}]]]$
- d. $*[_{CP} [_{DP} \text{who}] \text{did } [_{IP} [_{DP} A \text{ picture of } [_{DP} \text{who}]] \text{did } [_{vP} [_{DP} A \text{ picture of } [_{DP} \text{who}]] [_{VP} \text{hang on the wall}]]]]]$
- e. Contradictory ordering: $\langle \text{who}, a \text{ picture of} \rangle$ and $\langle a \text{ picture of}, \text{who} \rangle$

The contradictory ordering among the components of the subject DP causes the derivation to crash at the PF interface.

Now consider the case of intra-phasal movement, where no CED violation arises. Consider again example (34)b above, repeated here.

(39) ?What was there a book about stolen from the library?

At an early stage in the derivation, the internal argument raises to a position higher in the lower phase – the same position where stranded quantifiers appear. Note that XP is a label of convenience here. It can be the functional projection where accusative Case is checked if one assumes a split vP.

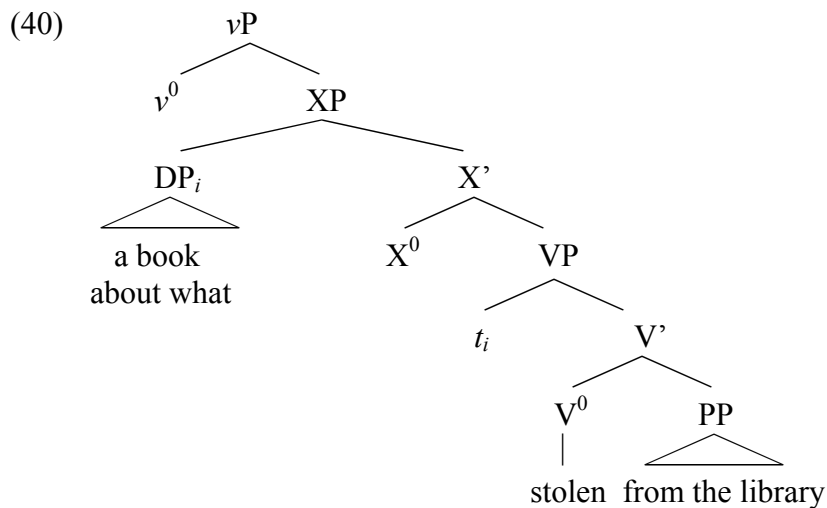

The *wh*-phrase is then extracted from DP and raises to the edge of the phase, SpecvP. Then, the phase undergoes Linearize and Spell-Out. In the next phase, the expletive *there* is merged in subject position, and the *wh*-phrase can continue to raise, eventually reaching the CP domain. This is shown in the following example. (The lowest copy of the argument is shown as a trace for reasons of space.)

(41) *Lack of CED effects in there passives*

a. [XP [DP a book about [DP what]]_i [VP stolen t_i from the library]]

- b. [_{VP} [_{DP} what]_j [_{VP} [_{XP} [_{DP} a book about [~~_{DP} what~~]_j]_i [_{VP} stolen *t_i* from the library]]]]]
- c. Linearize and Spell-Out – delete lower copies (shown in b.)
- d. [_{CP} [_{DP} what]_j was [_{TP} there ~~was~~ [_{VP} [~~_{DP} what~~]_j [_{VP} [_{XP} [_{DP} a book about [~~_{DP} what~~]_j]_i [_{VP} stolen *t_i* from the library]]]]]]]

We have seen that the heads-only approach to the LCA is too strong in its approach to CED violations as it rules out grammatical sentences. Since there are other possible explanations for CED effects, I assume that the LCA is defined in terms of all nodes, following Richards (2001). In the next subsection, I discuss the case of super-c-command that arises from Kayne’s original work and the definitions of the LCA and Antisymmetry to be pursued here.

2.2.2. Super C-Command

As discussed in Kayne (1994: 22-27), this approach has an interesting side effect that emerges if we examine a complex specifier in detail. Example (42) shows the phrase marker in (10) with the specifier AP presented in full.

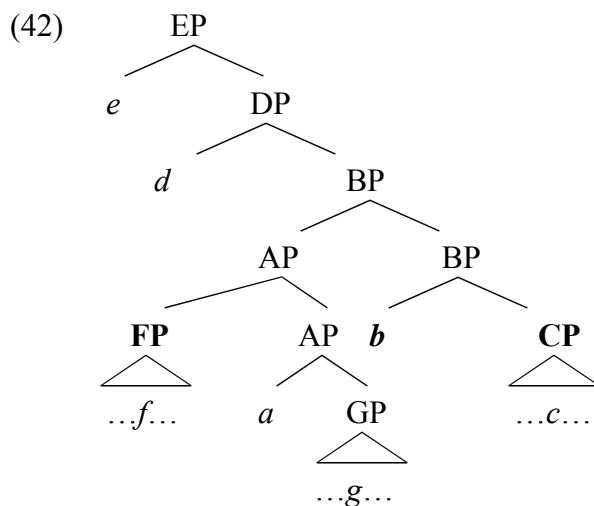

We see that, under the definitions for c-command adopted here (repeated in (43)), FP c-commands *b* and CP. Traditionally, only AP is thought to c-command into *b* and CP (Reinhart, 1976).

- (43) *x* c-commands *y* iff *x* excludes *y* and every category that dominates *x* dominates *y*.

In this section, we discuss some of the effects of super-c-command originally pointed out by Kayne (1994). I also propose that some phenomena previously described as feature percolation (Cowper, 1987) can be accounted for assuming that c-command works as outlined in this section.

To begin, the contrast between the two sentences in (44) is explained by the fact that *John* c-commands *himself* in (44)a, but not in (44)b. Since an anaphor such as *himself* requires a locally c-commanding antecedent, the second sentence is ungrammatical. The definition of c-command assumed here, however, has *John* c-commanding *himself* in both (44)a, and (44)b.

- (44) *Contrast in Principle A Effects*
- a. John_{*i*} likes himself_{*i*}.
 - b. * John_{*i*}'s mother likes himself_{*i*}.

Kayne (1994) offers the following examples, however, where a relation similar to c-command appears to hold between the specifier of a specifier, (FP in example (42)) and the relevant domain in question (*b* and CP in example (42)) – a relation that I refer to as *super c-command* for exposition.⁶⁵ In example (45)a, *every girl* binds the variable *she*, and in example (45)b *nobody* licences the negative polarity item *ever*.

⁶⁵ Note that Kayne's original GB conception of Antisymmetry makes the same predictions as the "all nodes" approach. Thus it is vital for Kayne to explain these facts.

(45) *Super c-command*

- a. Every girl_i's father thinks she_i is a genius. [Kayne, 1994: 23, ex. (15)]
- b. Nobody's articles ever get published fast enough. [*ibid*, p. 24, ex. (17)]

If these sentences are taken as evidence for super-c-command the examples in (44) are still problematic, since *John* c-commands *himself* in both sentences. Kayne (1994) assumes, following Szabolcsi (1981; 1983; 1992), that possessed DPs appear with a null D⁰ above them. He also assumes that the higher SpecDP, represented by the ellipsis, is an operator position and that operator positions are invisible to Conditions A, B and C of the Binding Theory. For clarity, the higher DP is labelled DP₁, the lower DP is labelled DP₂ and the possessor is labelled DP₃.

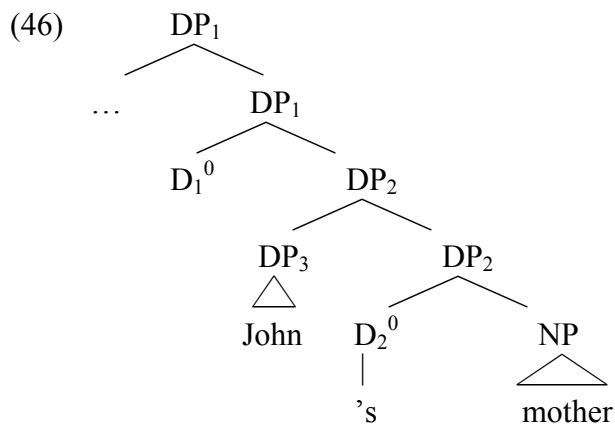

From this position, clearly *John* does not c-command outside of the higher DP (DP₁). In the sentences in (45) above, the QPs *every girl* and *nobody* must raise to the higher SpecDP₁ at LF so as to bind the variable or license the negative polarity item. The sentence in (47) is problematic, however, since *every girl* must raise to the higher SpecDP at LF, from which it can c-command the anaphor. Under the assumption that operator positions are invisible to Conditions A, B and C, once *every girl* raises to the

higher SpecDP, it is no longer in a position to satisfy Principle A and the sentence is ungrammatical.

(47) *Every girl_i's father likes herself_i.

Thus, reformulating the LCA as above on page 57 (repeated below) results in a system that approximates Kayne's original approach.

(48) A = the set of ordered pairs c such that X and Y are *nodes* in the syntactic tree and X asymmetrically c -commands Y

(49) $d(A)$ is the mapping from A to the set of ordered heads $\{ \langle x, y \rangle \}$, such that x is dominated by X and y is dominated by Y .

The result is that c -command now includes the cases we have been calling super c -command,⁶⁶ which accounts for the data in (45). The contrast in (44) is accounted for, given certain plausible assumptions about the structure of possessed DPs and the visibility of operator positions to A -binding.

We now consider other apparent cases of super- c -command. First, let's enlarge the paradigm from (45) above to include the following:

(50) *Super-c-command*

- a. Every girl_i's father thinks she_i is the smartest.
- b. The father of every girl_i thinks she_i is the smartest.
- c. The loser of every race_i thinks it_i was rigged.
- d. No one's papers ever get published fast enough.
- e. *Papers by no one ever get published fast enough.

⁶⁶ Recall that super- c -command is not a new relation; it is merely a useful label to distinguish cases of traditional c -command from those involving c -command by the specifier of a specifier. The grammar should make no distinctions between these two types of c -command, and, correspondingly, there should be no empirical difference between traditional c -command and super c -command, if we follow the line of argumentation outlined above.

The first three examples are problematic for the case of super-c-command. Although the definition of c-command assumed here allows *every girl* to c-command the bound pronoun in example (50)a, there is no way for the same DP to c-command the pronoun in example (50)b and (50)c. I would like to suggest that the data in (50)a-c be thought of in terms of Quantifier Raising (QR) rather than of c-command. In the relevant cases, the quantified DP undergoes QR at LF and can c-command the bound pronoun. This is confirmed by the following contrast:

- (51) The teacher of [every honours student]_i thinks he_i should feel proud of graduating.

In (51), there are potentially two readings: one in which the definite determiner takes scope over the quantified phrase *every honours student* (*the* > \forall); and another in which *every honours student* takes wide scope (\forall > *the*). However, if *he* is interpreted as a bound variable, as shown, only the inverse scope reading is available (\forall > *the*). That is, the quantified phrase, *every honours student*, must undergo QR at LF. However, if *he* is interpreted as coreferential with *the teacher*, then either scope reading is possible.

If the quantified phrase can undergo QR from the lower position, then it can move from the higher position, too. Thus, we have only shown that the pronoun can be bound by the quantified phrase in (50)a-c. We have not yet shown that it can be bound from its overt position as the specifier of a specifier as we are trying to show for (50)a. In order to do this we need to show that the quantified phrase in (50)a remains *in situ* at LF. To do this, we introduce another quantified phrase lower down in the sentence. Consider the sentence in (52), with *someone* taking scope over *every girl*. That is, there is someone such that every girl's father thinks she likes that person, for example, a famous teen idol.

(52) Every girl's father told someone to take her to the prom.

To get the inverse scope reading, *someone* must undergo QR and adjoin to IP at LF. Crucially, the subject must be interpreted *in situ* at LF, or we wouldn't get the inverse scope reading. Thus, from its *in situ* position, it must be able to bind the pronoun. To understand this better, consider the following LF representation of this sentence, where wavy underlining indicates which copy is interpreted at LF. Since *someone* must take scope over *every girl*, *every girl* must be interpreted in the specifier of the DP in the lowest specifier of IP.

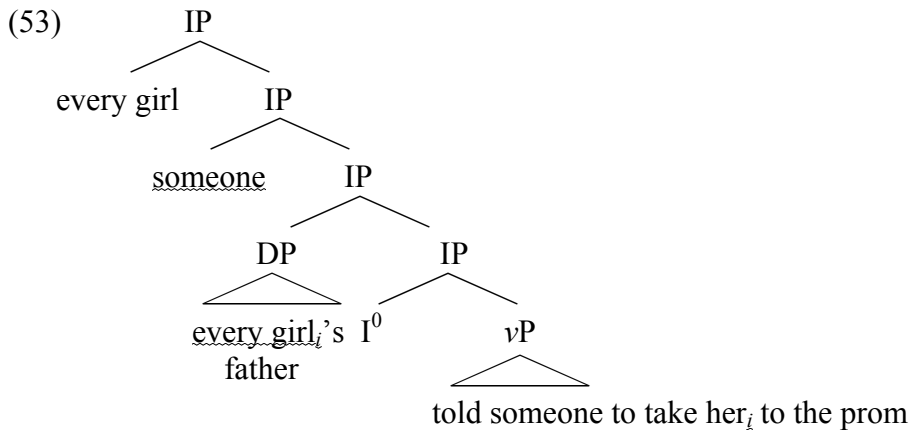

Note that the copies of the quantified phrases that undergo QR cannot appear in the opposite order, namely $*[_{IP} \textit{someone} [_{IP} \textit{every girl} [_{IP} \dots]]]$ as this configuration would violate superiority.⁶⁷

The second pair of examples also illustrates Kayne's point. In example (50)d, the negative polarity item *ever* must be c-commanded by something with a negative feature. The only available position is the specifier of the specifier above, thus substantiating super-c-command. The crucial structure is shown in (54). Recall that the quantified phrase, *no one*, undergoes QR to the highest SpecDP. From this position, it c-commands

⁶⁷ See (Bruening, 2001) for arguments that QR must obey superiority.

the NPI *ever*. Recall that DP₁ does not dominate DP₃, *no one*, since there is at least one segment of DP₁ that does not dominate DP₃. Thus, the only category that dominates DP₃ is CP, which also dominates the NPI *ever*, and DP₃ therefore c-commands *ever*.

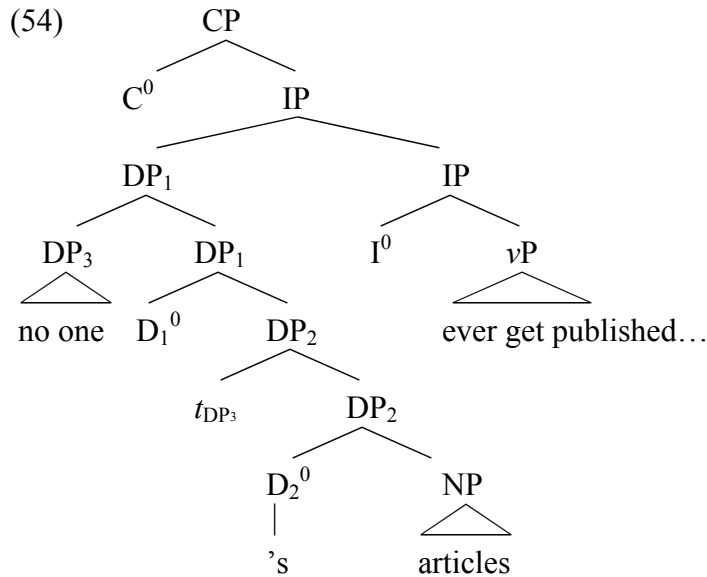

The ungrammatical example (50)e confirms that a more deeply embedded negative item cannot c-command out, thus this sentence is ungrammatical.

Once we acknowledge that c-command is available from the specifier of a specifier (super-c-command), we can explain other facts previously analyzed with feature percolation. Consider the following examples, adapted from Cowper (1987):

(55) *Possessed DPs in English*

- a. The cat's collar
- b. A cat's collar
- c. Which cat's collar

Consider first the structure for these DPs.

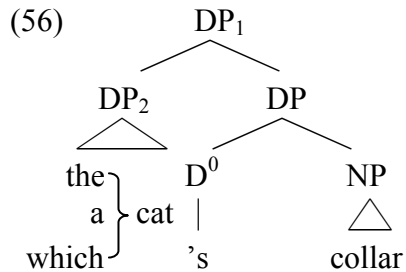

In the examples in (55) the possessor is [+definite], [-definite] or [+wh], respectively. In each case, however, the entire DP₁ has the same feature as its specifier, DP₂. The following test shows this for the first two examples:

(57) *Definiteness Effects with Possessed DPs in English*

- a. *There's the cat's collar on the table.
- b. There's a/some cat's collar on the table.

The test in example (57) shows that a DP possessed by a definite-marked possessor must itself be definite. Definite DPs cannot be the associate to a *there*-expletive in existential constructions. The (b) example is grammatical, showing that it can have an indefinite reading. The [+wh] feature of the entire DP is shown by its ability to raise and check the [+wh] feature in CP.

(58) [DP [DP Which cat]'s collar]_i did you throw *t_i* away?

Cowper (1987) accounted for this effect using *feature percolation*. Before considering her analysis, let us examine the parallels between the examples in (55) above and the negative polarity licensing data in (50)d and e above. The following paradigm shows that NPI licensing parallels definiteness and *wh*-features.

(59) *Possessed DPs in English*

- a. There's a friend of Mary's at the door.
- b. *There's Mary's friend at the door.
- c. Which cat's collar did you throw out?
- d. *The collar from which cat did you throw out?

- e. No one's articles ever get published fast enough.
- f. *Articles by no one ever get published fast enough.

In all three cases, the features of the specifier seem to percolate to the main DP, while the features of the complement inside the DP do not. This is shown schematically in (60), where the solid arrow indicates feature percolation, and the dashed arrow indicates lack of feature percolation.

(60) *Schematic complex DPs*

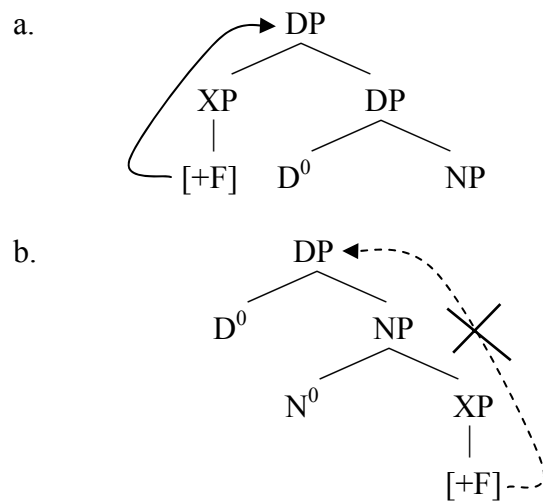

Under a version of minimalism that involves a probe searching for an active goal (Béjar, 2003; Chomsky, 2000, 2001b; Rezac, 2004a), the C⁰ carries a feature [*uWh*] that searches for and finds an active [*Wh*] feature. In this case, it targets the [*Wh*] feature on *which cat* and pied-pipes the whole DP, [_{DP} [_{DP} *which cat*]'s collar], rather than moving only the specifier [_{DP} *which cat*]. The traditional explanation for the specifier failing to raise on its own is that it would strand the string *'s collar*, which is morphologically ill-formed. The reason that the DP, [_{DP} *the collar of which cat*] does not raise is that a smaller phrase can raise, stranding the preposition, thus respecting Least Effort.

I would like to suggest an alternative explanation. When an XP is targeted for overt movement to SpecCP after Agree has taken place, in theory, any XP should do,

since only the feature EPP of C^0 needs to be satisfied. Clearly, however, only some XP that contains the *wh*-phrase that originally matched the $[uWh]$ feature on C^0 can raise. I propose that the phrase bearing the interpretable $[Wh]$ feature must c-command C^0 , when EPP is satisfied. In essence, I propose the following principle.

- (61) **Principle of EPP Satisfaction:** EPP on a head, H^0 , with $[uF]$ can be satisfied either by an expletive⁶⁸, or by an XP that bears the feature $[iF]$ with which $[uF]$ was valued. $[iF]$ must c-command $[uF]$.⁶⁹

Let's consider this proposal in light of the following three crucial sentences.

- (62) *Wh-DPs in English*
- a. Which cat did you buy a collar for?
 - b. Which cat's collar did you throw out?
 - c. *The collar from which cat did you throw out?

In the first two cases, the DP $[_{DP}$ which cat] c-commands C^0 under the definition of c-command adopted here. In the last sentence, however, the DP $[_{DP}$ which cat] does not c-command C^0 under any definition of c-command. These three cases are illustrated here. Note, I abstract away from the multiple DP structure proposed for possessed DPs since it does not bear on the analysis presented here.

- (63) *Wh-DPs in English*

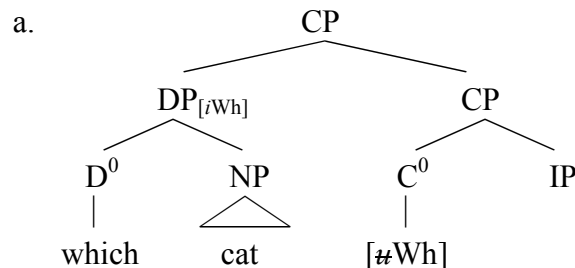

⁶⁸ It may not be necessary to include the condition on expletives in this principle if we assume that expletives always check a categorial feature. See Rezac (2004b) for related discussion.

⁶⁹ Recall that I remain agnostic on the issue as to whether linear compression is the sole trigger for movement or not. The discussion here would seem to suggest that other triggers for movement are available to the grammar.

What is important to remember for these examples is that the features present on a given head are present in the label of the maximal projection of that head. Thus, the DP in the tree above contains the feature [*iWh*] in its label. This tree clearly satisfies the Principle of EPP Satisfaction above, since DP c-commands C⁰.

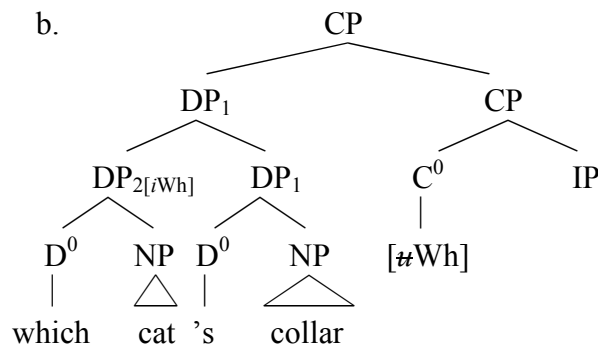

In (63)b, DP₂, which contains the feature [*iWh*] in its label, c-commands C⁰. This is so, because DP₁ does not dominate DP₂, and DP₂ is able to c-command out of SpecCP into C⁰. The feature that underwent Agree with [*uWh*] c-commands C⁰, thereby satisfying the Principle of EPP Satisfaction.

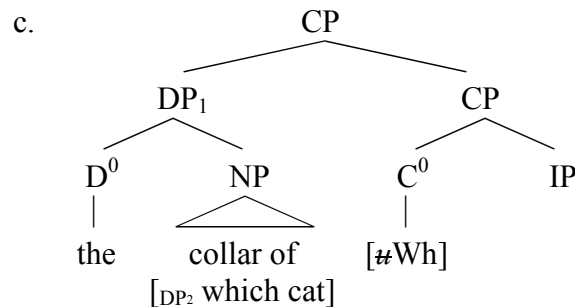

In this tree, the DP₂, *which cat*, which contains the feature [*iWh*] in its label, does not c-command C⁰ because it is dominated by DP₁ in SpecCP. Thus, the Principle of EPP Satisfaction is not satisfied, and the derivation crashes.⁷⁰

⁷⁰ Gabriela Alboiu (pc) points out that [*uWh*] on C⁰ should remain unchecked, thereby causing the derivation to crash, too. The relevant question here is whether [*uWh*] is valued by the *wh*-phrase *in situ* or whether raising to SpecCP is required for feature valuation. I see no immediate means of teasing apart these two theoretical possibilities and leave the question for future research.

Let us now consider the traditional explanation of these facts, which relies on Least Effort. I adopt the traditional explanation that the stranded sequence, $[_{DP} t \text{'s collar}]$, is ill-formed.⁷¹ Consider, however, the sentences in (64) in which subjacency violations have been repaired with resumptive pronouns.

(64) *English Subjacency Violations*

- a. Which cat do you wonder whether Mary bought its collar?
- b. Which cat's collar do you wonder whether Mary bought it?
- c. *The collar of which cat do you wonder whether Mary bought it?

In (64)a, the stranded possessive marker is supported by the resumptive pronoun and the sentence is well-formed. If Least Effort were all that were at stake, then we would expect (64)b to be ruled out since a smaller XP, $[_{DP} \text{which cat}]$, is available for movement. However, under the view I proposed above, namely, that the raised XP must contain a *wh*-phrase that c-commands C^0 , the facts fall into place neatly. In the first two examples, the *wh*-phrase, *which NP*, c-commands C^0 , but in (64)c, the *wh*-phrase does not c-command C^0 , so this sentence is ungrammatical.

Potential evidence against the Principle of EPP Satisfaction is found in pied-piping examples such as the following:

(65) To whom should we speak?

In (65) it appears that the PP, *to whom*, has raised to SpecCP to check the $[_uWh]$ feature on C^0 . This would be a violation of the Principle of EPP satisfaction, since the bearer of the $[_iWh]$ feature is inside the PP and cannot c-command C^0 from SpecCP. This is shown in the following structure

⁷¹ I do not discuss the nature of this ill-formedness here, other than to suggest that it violates some phonological constraint on English clitics, perhaps an updated version of the Stranded Affix Filter (Lasnik, 1981).

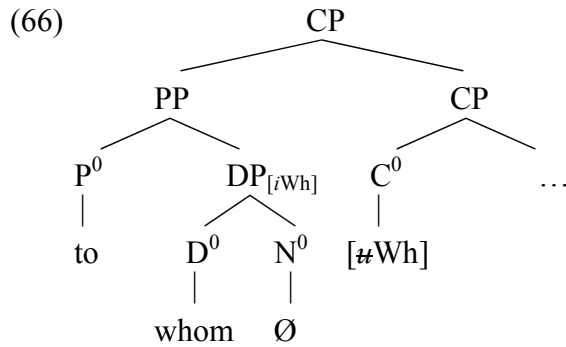

Kayne (2004a) argues that the string *to whom* is not actually a constituent.⁷² Some evidence he cites in favour of this claim is the difference in grammaticality upon extraction across a *wh*-island. In the following examples, lack of pied-piping leads to mild ungrammaticality (presumably related to extraction across an island), while pied-piping leads to full ungrammaticality (Kayne’s judgements).

(67) *Extraction across a wh-island and pied-piping* [Kayne, 2004:208, ex 110-111]

- a. ?Who did John fall asleep while talking to?
- b. *To whom did John fall asleep while talking?

Under the traditional explanation of pied-piping, one would have to seek out a solution in which the availability of pied-piping versus preposition stranding depends upon whether extraction across an island takes place. Kayne suggests that a more fruitful approach would be to assume that the preposition moves independently of the DP in instances of “pied-piping”. In the case of extraction across a *wh*-island, the *wh*-phrase can establish a dependency between the raised and merged position, but the preposition cannot.

Furthermore, Kayne notes further that the preposition can be pronounced in both the higher and the lower positions.

(68) ?To whom was John speaking to?

⁷² Kayne’s original explanation for not treating strings such as *to whom* as a constituent has to do with the need for a uniform derivation of prepositional phrases and postpositional phrases within an Antisymmetric framework. The reader is referred to the literature for details (Kayne, 1994, 2003a, 2003b, 2004a).

This leads Kayne to suggest that a preposition is merged twice – once in the *in situ* position and once in the left periphery. I adopt this idea and implement it as follows. Assuming some version of a split CP (Rizzi, 1997, 1999), the DP raises to SpecIntP (=Interrogative Phrase), where the [*i*Wh] feature on DP c-commands the checked [$\#$ Wh] feature on Int⁰, thereby satisfying the Principle of EPP satisfaction. Then, another preposition is merged above, forming a dependency with the preposition in the embedded clause.

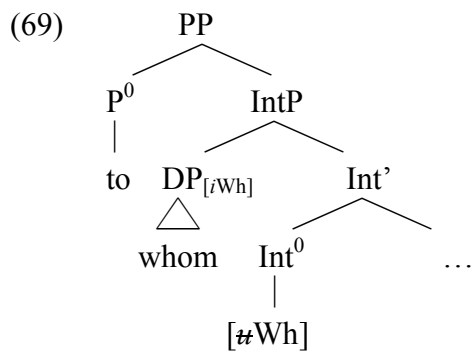

Further evidence that the higher preposition is not a copy of the lower preposition but is a different preposition altogether that forms a dependency with the lower preposition is found in the following example.⁷³ The crucial part of the sentence is underlined.

(70) To whom should I speak with at your company concerning these type [sic] of services?

In (70), the preposition in the left periphery, *to*, is different from the preposition in the *in situ* position, *with*. Thus, one cannot argue for a movement analysis of the preposition (or indeed the PP) in the face of examples such as this. Thus, following the line of argumentation above, so-called cases of pied-piping are not problematic for the Principle of EPP Satisfaction.

⁷³ Examples such as this are easily found with www.google.com using search terms such as “to whom should * speak with” for matrix questions or “to whom * should speak with” for embedded questions. See Reich (2005) for a discussion on using Google as a tool for linguistic field work.

To conclude, we have seen that so-called super c-command, that is, c-command from the specifier of a specifier, must be possible under any version of Antisymmetry. I have reviewed Kayne's original discussion of this matter and have augmented his discussion to include some other cases previously analyzed in terms of feature percolation in Cowper (1987).

2.3. The Problem of Mutual C-command

Antisymmetry was originally formulated to derive the effects of X-bar theory. With the elimination of X-bar theory from UG in favour of Bare Phrase Structure (Chomsky, 1994), certain aspects of Antisymmetry must be re-examined. We have seen above that the LCA is now seen to hold only at PF, not throughout the entire derivation. Let us now consider how the definitions in Kayne (1994) and their implementation carry over to a Bare Phrase Structure framework. Consider the following structure, consistent with the principles of Bare Phrase Structure, where either or both of α and β are heads:

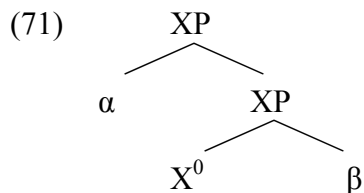

This representation was originally ruled out by Kayne (1994). Kayne's original reason for prohibiting structures like (71) was that he was attempting to derive the principles of X-bar Theory, which did not permit heads in specifier⁷⁴ or complementizer position. This type of structure, however, is permissible, and indeed unavoidable in Bare Phrase Structure.

⁷⁴ Bošković (2002) proposes that syntactic clitics are obligatorily non-branching elements that appear as either the specifier or complement of a functional projection.

Consider the initial merger of two heads at the very beginning of a syntactic derivation:

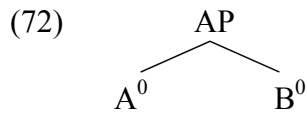

The representation in (72), which is perfectly acceptable in Bare Phrase Structure, violates the LCA because A^0 and B^0 c-command each other. Notice that even here, Kayne’s original conception of phrase structure is not respected, since, according to X-bar theory, only an XP can appear as the complement to a head. However, no other option is available in Bare Phrase Structure, since initial merge necessarily applies to two heads. I refer to this problem as the Initial Merger Problem (Initial Merger Problem) and it is the core problem to be dealt with in the next section.

2.4. Proposal

The previous section pointed out that the initial merger of two heads creates a configuration of symmetric c-command, which must be resolved in order for the LCA to linearize the structure. The point of symmetry in (72) above can be eliminated by raising the complement to specifier position in AP:⁷⁵

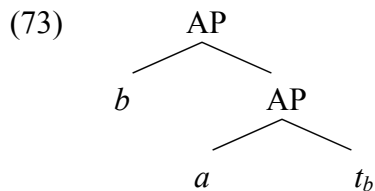

⁷⁵ It has often been argued that complement-to-specifier raising within the same projection is ruled out. Kayne (2004b), in particular, rules this type of movement out because of feature checking. Since phrases move to check features, it follows that movement can take place only to a new feature checking position. Thus, any phrase that checks its features in the complement of a head, H^0 , will have no further features to check against H^0 in SpecHP. Since I propose that b in (73) moves to SpecAP not to check a feature, but to eliminate a point of symmetry, I assume this movement is not problematic. This proposal is consistent with a view of syntax in which complement-to-specifier movement for feature checking is ruled out.

At this point, b , strictly speaking, c-commands a , since every category that dominates b (none, in fact) also dominates a . In other words, there is no category that dominates b that does not dominate a . Since a , but not b is dominated by AP, a does not c-command b . Thus, b *vacuously*, and asymmetrically, c-commands a since b is undominated, and b and a can be linearized.

Before continuing, I would like to re-iterate that I am assuming a Copy Theory of movement as in Chomsky (2000 et seq.) whereby Copy Deletion (specifically the choice of which copy to delete) takes place along the lines suggested by Nunes (2004). Thus, traces are used here as a shorthand for copies that are deleted at PF. Note that this does not rule out the possibility of pronouncing lower copies altogether; however, lower copies that violate the LCA (such as t_b in (73) above) cannot be realized.

The definition of c-command assumed thus far suffers from a potential problem when more than one tree is involved (such as in parallel derivations). Consider the two trees being formed in parallel.

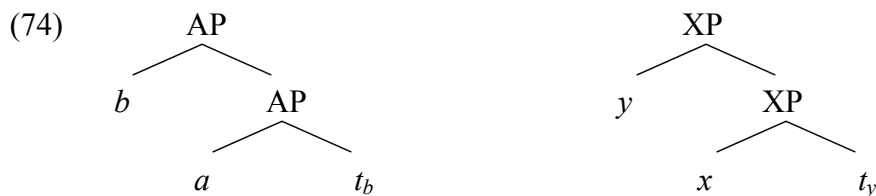

If we consider the pair $\{b, y\}$, taking the definition of c-command literally, b c-commands y , since every maximal projection that dominates b (which, again, is none) also c-commands y . This is unproblematic, however, since y also c-commands b , thus the “structure” in (74) is unlinearizable. This is a welcome result as it captures that notion

that a derivation does not converge unless it forms a single phrase marker without further stipulation.⁷⁶

Now, once a new head, *c*, is merged with AP as in (75), no asymmetric c-command relation holds between *b* and *c*. Now, it is *b* and *c* that cannot be linearized.

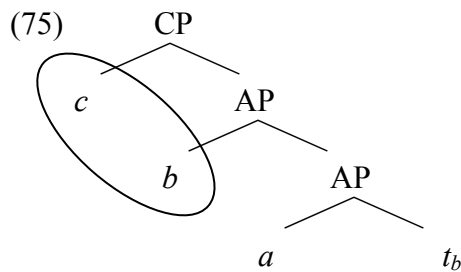

In (75), *b* and *c* are dominated by the same set of maximal projections, namely CP. *b* is not dominated by AP since not every segment of AP dominates *b*. Thus, every category that dominates *b* also dominates *c* and every category that dominates *c* also dominates *b*.

However, asymmetric c-command can be established between *c* and *b* the same way as between *a* and *b* above. That is, AP can raise to the specifier of CP. This gives us the tree structure shown in (76) and the linear order of heads shown in (77).⁷⁷

⁷⁶ Note that we may still need to revise the definition of c-command if it turns out that the current definition creates problems for binding. Kayne recognized this problem (since the same problem existed in his formulation of Antisymmetry). His solution was to posit an abstract empty head that takes the root of the phrase marker as its complement. This would always give some maximal projection to dominate the specifier of the root XP. This option is unavailable, of course, in a derivational framework. This is because linearization is computed at each step of the derivation, and effects changes accordingly (as we saw for the transition from (72) to (73)). The abstract head taking the root XP as a complement would not appear until the very end of the derivation, and would be useless to help establish linear order in (73). If one wanted to capture this idea here, one could amend the definition of c-command as follows:

i. *x* c-commands *y* iff *x* excludes *y* and every category that dominates *x* dominates *y*, and there is at least one α , α an XP or segment of an XP, that dominates both *x* and *y*.

⁷⁷ Another option, of course, is to raise *b* to SpecCP. I discuss this option below in section 2.5.1.

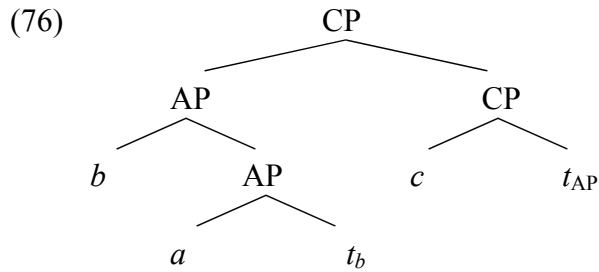

(77) $b < a < c$

By this logic, however, the complement of every head will necessarily move into the specifier of that head for the entire derivation! If another head, d , merges with the derivation CP will have to raise to the specifier of DP to eliminate symmetric c-command.

Consider, however, a situation in which c does not have any phonological material. In such a case, it is unnecessary for c and b to be linearized (Moro, 2000).⁷⁸ Recall that the LCA is a PF constraint, and PF does not care about linearizing elements that do not have any phonological content. Now let's consider what happens if c in (75) is phonologically empty. No further movement is necessary. If another (phonologically specified) head, d , is merged with the phrase marker in (75) giving (78), asymmetric c-command holds between d and b :

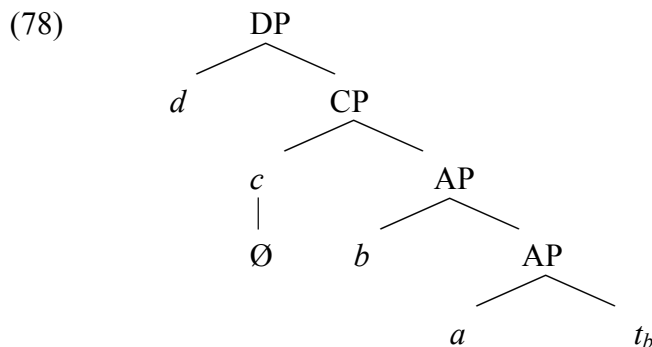

⁷⁸ Moro (2000) suggested that empty heads other than traces (such as *pro*) do not need to be linearized. He also conjectured that the amount of movement in a given language should be inversely proportional to the number of empty categories in that language.

Here, asymmetric c-command holds between d , b and a , giving the surface order $d < b < a$, as suggested by the phrase marker shown. The remaining head, c , does not participate in linear order since it is phonologically empty.

We have just seen that merger of a phonologically empty head halts Compl-to-spec roll-up of the derivation. We now examine the consequence of the initial merger of a non-projecting phonologically empty head. In other words, we merge two heads, a and b , where b is phonologically null and a projects. At the outset, this structure presents no problem for the LCA, since there is only one head that needs to be linearized – a . Next, we merge another head, c , with the structure thus formed. The result is shown in (79). In the phrase marker in this example, c asymmetrically c-commands a , thus establishing the linear order $c < a$. b is not ordered with respect to a , but this does not matter, since b is phonologically null and thus not subject to the LCA. In this scenario, compl-to-spec roll-up never takes place. Observe further that if more phonologically specified heads are merged into the structure in (79), linear order can still be established for all the phonologically specified heads. Example (80) shows another head, d , which asymmetrically c-commands c , which in turn asymmetrically c-commands a . This structure can be linearized as $d < c < a$ as it stands, with b not entering the linearization process as it is phonologically null.

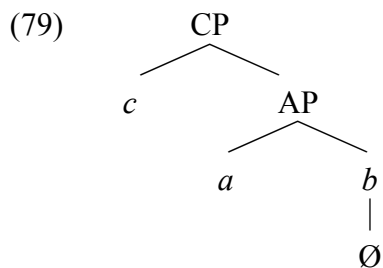

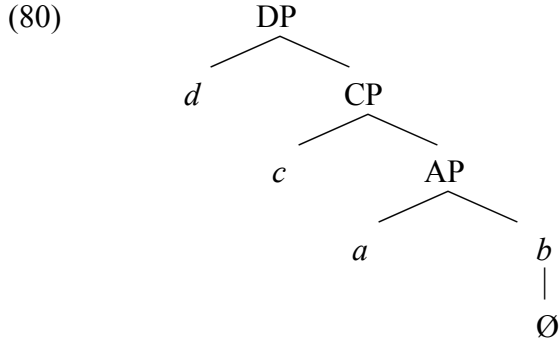

Now consider the situation in which the projecting head in initial Merge is phonologically null. This is essentially the same as (78). The phrase marker in (81) shows that *c* asymmetrically *c*-commands *b*, thus *c* precedes *b*. *a* and *b* are not in an asymmetric *c*-command relation; however the LCA does not see *a* for the purposes of linearization, so this tree converges with the linear order $c < b$.

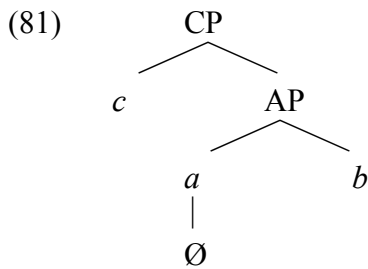

The presence of a phonologically null head does not necessarily stop Compl-to-spec roll-up. Consider again the case where a phonologically null head, *a*, selects another head, *b*, as its complement. As above, no movement is required. But now, suppose that another head, *c*, merges with AP, and AP projects, so that *c* is in SpecAP. This is shown in (82).

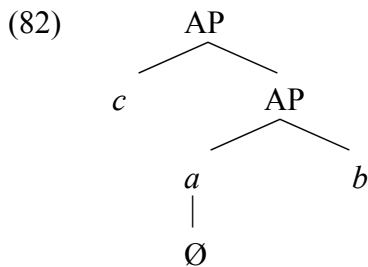

At this point, no movement needs to take place, since *c* asymmetrically c-commands *b*. Now, another head, *d*, merges with AP and *d* projects giving . *d* and *c* are in a symmetric c-command relation.

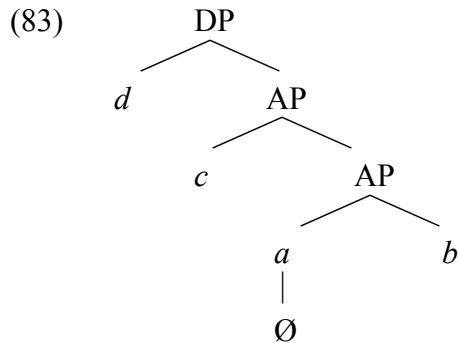

Unless *d* is phonologically empty, AP must raise to SpecDP to eliminate symmetric c-command and satisfy the LCA. This is shown in (84).

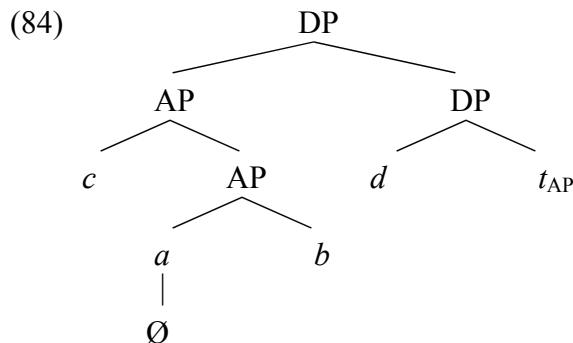

The LCA is thus compatible with Bare Phrase Structure if, following Chomsky (1995) and Moro (2000), we eliminate the purely X-bar theoretic constraints on phrase structure assumed by Kayne (1994). Heads may occupy complement and specifier positions as Bare Phrase Structure dictates, and the LCA ignores phonologically empty heads.

This proposal crucially relies on being able to identify phonologically empty heads. The danger here, of course, lies in the possibility of conjuring up a phonologically null head wherever needed to stop Compl-to-spec roll-up, thereby achieving the correct

word order for the language under consideration. Following Wiltschko (2004), I assume that a lexical object, LO, contains phonological information, π , semantic information, λ , and categorial information, κ .

$$(85) \quad \text{LO} = \langle \pi, \lambda, \kappa \rangle$$

Furthermore, at most one of these entries can be absent. Thus, phonologically null heads must contain semantic information and a categorial label (that is, it cannot be an adjunct). It follows, then, the phonologically null head we assume must have some semantic import. Assume, for example, we have a sequence of two words that can vary as shown in (86) and (87), where the first example is formed by X^0 raising to SpecYP in the manner described here.

$$(86) \quad X^0 \dots Y^0 \dots t_{X^0}$$

$$(87) \quad Y^0 \dots X^0$$

$$(88) \quad Y^0 \dots F_{[\emptyset]}^0 \dots X^0$$

If the order in (87) is also available in the language, we would have to posit a phonologically null head, F^0 , between X^0 and Y^0 to stop roll-up, as shown in (88). If this is the case, F^0 must carry some semantic information, which implies some semantic difference between (86) and (87).

2.5. Alternatives to Compl-to-spec Roll-up

I have proposed a theory of phrase structure in which the LCA is satisfied by Compl-to-spec roll-up of successively merged heads until a phonologically null head is reached. One could envision other alternatives to the mechanism developed here. For instance,

once the structure in (89) is obtained, one could imagine that *b* above, rather than AP, could raise to SpecCP to satisfy the LCA.

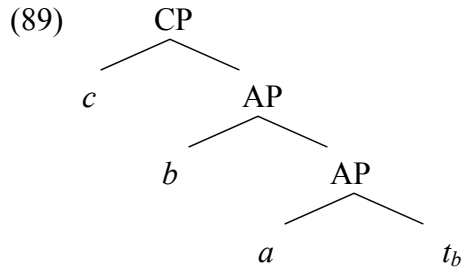

Such a movement would derive the structure in (90).

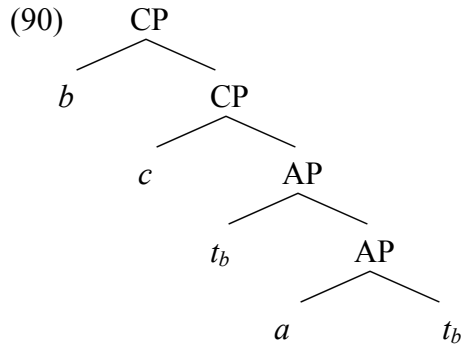

The structure in (90) satisfies the LCA, but gives rise to the linear order $\langle b, c, a \rangle$ rather than $\langle b, a, c \rangle$. Another logical possibility is to simply bar the initial merger of two phonologically specified heads altogether and ensure either that one of the heads that participates in initial merger is phonologically null or that the complement is not a head, but rather a previously formed full XP. We will look at each of these options in turn in this section.

2.5.1. *Spec-to-Spec Movement and Romance Clitics*

The first alternative for eliminating symmetric c-command is raising the offending specifier rather than pied-piping the entire XP that contains it. These two possibilities are shown in (91).

(91) *Rectifying a Head and Specifier in Symmetric C-Command*

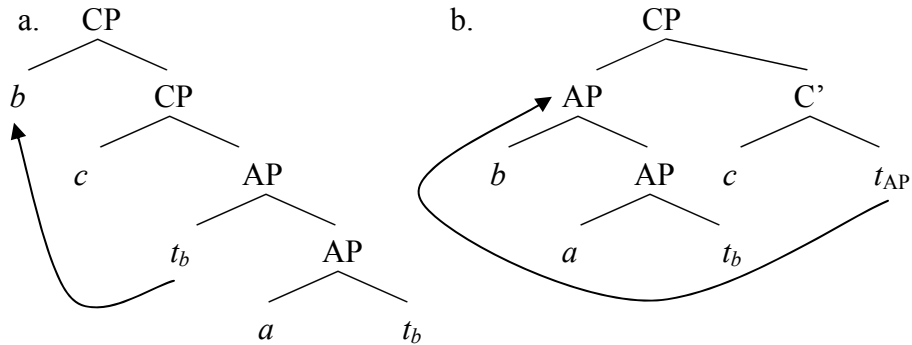

I suggest here that the default approach to eliminating symmetric c-command is that in (91)b. What I propose is that the syntax obeys some formulation of Shortest Move in deciding which constituent to raise to eliminate symmetric c-command. Furthermore, I assume that the derivation looks down from the top and moves the first constituent possible that will eliminate the symmetric c-command, which in this example is AP. The issue of pied piping may be a concern here, since the derivation we want involves moving a larger unit, AP, than does the derivation we wish to rule out, which moves only *b*. Under a minimalist approach, this might appear counter-intuitive. I would like to suggest that the issue of pied-piping is an all or nothing decision – either it happens or it doesn't based on whether an EPP feature is present or not. The size of the constituent that is pied piped is determined by discourse or other factors, as long as the Principle of EPP Satisfaction is satisfied. This is suggested by the data on *wh*-movement with resumptive pronouns above, repeated here.⁷⁹

⁷⁹ This is also strongly suggested by Ross' (1967) discussion on relative clauses where multiple outcomes are permitted:

- i. These are the reports that the government prescribes the height of the lettering on the covers of.
- ii. These are the reports, the covers of which the government prescribed the height of the lettering on.
- iii. These are the reports, the lettering on the covers of which the government prescribes the height of.

(92) *Pied-Piping*

- a. Which cat's collar did you lose?
- b. *[Which cat]_i did you lose *t_i's* collar?
- c. Which cat do you wonder whether Mary lost its collar?
- d. Which cat's collar do you wonder whether Mary lost (it)?
- e. *The collar of which cat do you wonder whether Mary lost it?

Recall that the traditional explanation for the contrast in (92)a and b is that the phrase [DP which cat's collar] is the smallest XP that can be moved, without violating any morphological constraint on the English possessive morpheme (that is, without stranding 's without a host). I argued above that this claim cannot be maintained in light of the data in (92)c, d and e. Crucially, either *which cat* or *which cat's collar* can raise, since there is a resumptive pronoun to host the possessive morpheme. Thus, whenever phonological material is pied-piped, be it to satisfy EPP or eliminate symmetric c-command, I propose that the *weight* of the moved element, that is how much phonological material it possesses, does not play a role directly in the syntax, other than ensuring that the Principle of EPP Satisfaction is satisfied.⁸⁰ In the case of eliminating symmetric c-command, I appeal to Shortest Move, which requires the closest element to the landing site be moved. In the structure in (89) above, repeated here, AP is closer to the landing site than *b* is, thus, AP is moved.

-
- iv. These are the reports, the height of the lettering on the covers of which the government prescribes.

⁸⁰ Note that Ross (1967) accounted for some of these effects with the Left Branch Condition. Consider the following examples.

- i. *How is she [*t* tall]?
- ii. *Which did you steal [*t* book]?

In both cases, the left side of the constituent has been extracted. There are languages in which constructions such as these are grammatical (see Bošković, 2005; Moro, 2000). Thus, a general prohibition as proposed by Ross is too strong. See the authors cited for explanations of Left Branch Condition effects.

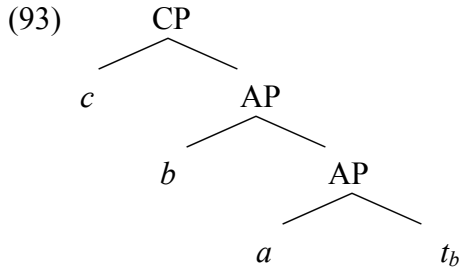

Now, we can ask whether there is any reason to think that the syntax may want to move just the head, *b*. This idea presented here is still somewhat speculative and proceeds as follows: If *b* has some unfulfilled requirement⁸¹ or unchecked feature, then the syntax will opt to move *b* instead of AP, to bring *b* closer to fulfilling its requirement.

An example of such a scenario is clitic climbing in Romance. Romance pronominal clitics must raise to a tensed IP domain (Kayne, 1989, 1991). When a verb and a clitic are merged, they form an instance of symmetric c-command, which is resolved by raising the clitic to SpecVP. The following example shows the VP portion of the Italian sentence, *lo vedo*, ‘I see it.’

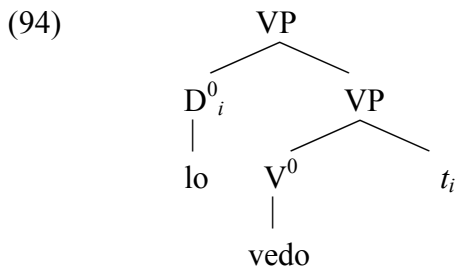

Wurmbrand (1998) has argued that certain infinitival complements are bare VPs. If the VP is selected by a modal verb, the modal and the clitic form a point of symmetric c-command; however, the clitic has an independent need to raise to the IP domain, so only the clitic raises, while the rest of the VP remains. The structure in (95) illustrates this

⁸¹ This statement sounds more compatible with a theory of feature checking that relies on Greed rather than on Attract. One can think of it as a way of saying that *b* has some feature that will enter into an Agree relation later in the derivation. In the case considered here, the “unfulfilled requirement” is for a pronominal clitic in Romance to appear in the IP domain – a fact not quite clearly understood, but commonly accepted.

point for the sentence, *lo posso vedere* (Italian; ‘I can see it.’) where only the relevant parts of the tree are shown. Crucially, the clitic alone raises to the IP domain, rather than the entire embedded VP, as would be suggested by my proposal above.⁸²

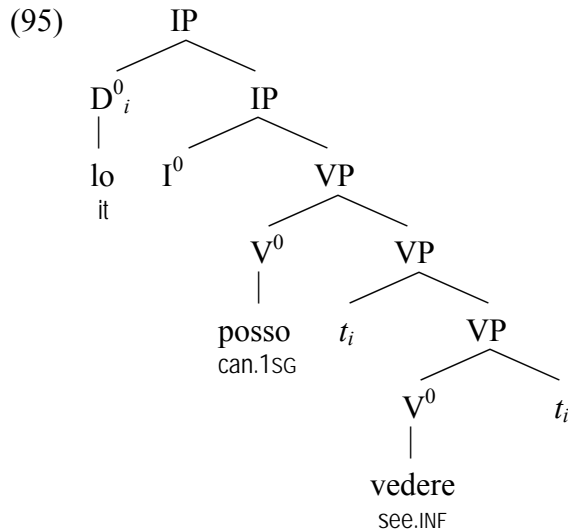

The goal of this section was to outline a possible ramification of the proposal developed here rather than to give a comprehensive account of clitic climbing in Romance. We have seen that the clitic’s need to appear in the IP domain might trigger movement of a lower node than is necessary to remove an instance of symmetric c-command.

2.5.2. *Avoidance of the Initial Merger Problem*

As mentioned above, another possible solution to the Initial Merger Problem is to avoid it altogether; that is, at initial Merge, one or both of the two heads must be phonologically null. It is difficult to imagine this scenario as a general solution to the problem, however, as it would require some *ad hoc* constraint requiring at least one of the heads involved in

⁸² Still unexplained are the cases where clitic climbing does not take place:

- i. Posso vederlo.
can.1SG see.INF.CL.3.SG
‘I can see it.’

initial merger to be null – a rather odd constraint.⁸³ Nevertheless, it is possible to imagine a scenario in which the structure resulting from Compl-to-spec roll-up is ill-formed either morphologically or otherwise. In this case, no convergent derivation emerges from the Numeration in which initial merger of two phonologically specified heads takes place. Thus, some other construction (and corresponding Numeration) must be used.

For example, consider a preposition taking either a bare noun or a full DP as a complement. First, we consider what happens in principle in the situation and then we examine some Russian data that illustrates what is going on here.

(96) *Complements to P⁰*

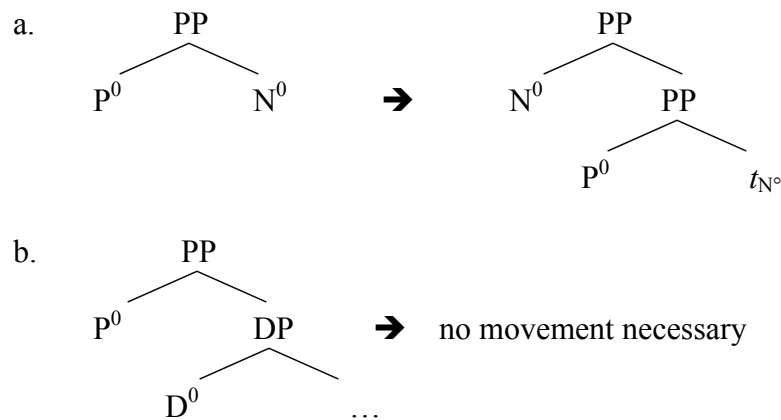

In (96)a, the bare noun must raise to SpecPP to satisfy the LCA as shown; whereas in (96)b, the LCA is satisfied without any further movement. The resultant structure in the first example (linear order $\langle N^0, P^0 \rangle$) may violate some morphological filter or otherwise be illicit.⁸⁴ As a result, bare nouns would not be permitted in this scenario. Only full DP complements would result in a grammatical structure.

⁸³ Under a non-dynamic view of Antisymmetry, the LCA would simply rule such structures out, but then noun incorporation would remain mysterious under this view.

⁸⁴ In the case of the Russian data described below, Babyonyshev does discuss why the sequence $\langle N^0, P^0 \rangle$ may be ungrammatical. She claims that this underlying structure does not surface to avoid an LCA violation. Ultimately, the answer lies in a better understanding, on my part, of Russian morphology. I would like to add, however, that blocking unwanted derivations in a given language may ultimately rest on

Babyonyshev (2002) discusses deverbal nouns in Russian with object complements. The following examples bear on the discussion (data from Babyonyshev, 2002).

(97) *Russian Deverbal Nouns with Complements*

- a. *unizhenie tebja (Vanej)
 humiliation 2.SG.GEN (Vanya.INSTR)
 ('the humiliation of you (by Vanya)')
- b. unizhenie mamy (Vanej)
 humiliation mom.GEN (Vanya.INSTR)
 'the humiliation of mom (by Vanya)'
- c. unizhenie ego i ego brata
 humiliation 3.SG.M.GEN and his brother.GEN
 the humiliation of him and his brother
- d. unizhenie tebja, Petra Petrova
 humiliation 2.SG.GEN, Petr.GEN Petrov.GEN
 'the humiliation of you, Petr Petrov'
- e. rukovodstvo vami
 leadership you.INSTR
 'the leadership of you'
- f. *tebja unizhenie (Vanej)
 2.SG.GEN humiliation (Vanya.INSTR)
 ('the humiliation of you (by Vanya)')

Babyonyshev argues that *tebja* ('you-GEN') in (97)a is a bare D⁰ complement to the deverbal noun, while *mamy* ('mom-GEN') in (97)b is a full DP.⁸⁵ This is illustrated in (98) and (99).

stipulation, pending a better understanding of the fact. For example, scrambling is freely available in Japanese, but much less so in English. One could argue that English DPs must appear in Case positions, while in Japanese this requirement does not hold, but this is just shifting the burden of explanation to another module of the grammar.

⁸⁵ The ensuing discussion may run counter to the proposal in Déchaine and Wiltschko (2002) that pronouns have a high degree of internal structure. Thus, the pronoun *tebja* would have the following structure.

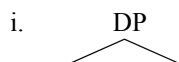

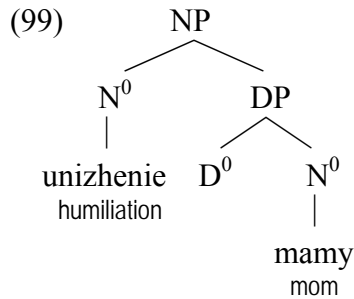
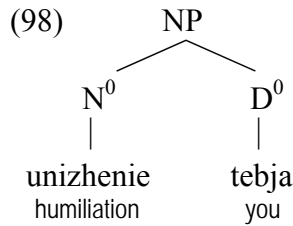

Babyonyshev argues that (98) violates the LCA because the noun and the pronoun are in a symmetric c-command configuration. This structure, thus, cannot be linearized and the derivation crashes at the PF interface. Example (99), on the other hand, does not violate the LCA. This structure can be linearized, and the derivation converges. Note that (98) cannot be salvaged by Compl-to-spec roll-up as shown by the ungrammaticality of (97)f. I assume that this construction is ruled out by some other property of the grammar, such as some sort of morphological filter against the resultant structure, *tebja unizhenie*, ('your humiliation') that would result upon raising D^0 to SpecNP. I leave this question open to future research.⁸⁶ To show that (97)a is not ungrammatical simply because of the use of a

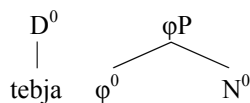

When this structure merges with a deverbal noun, no LCA violation is incurred and the structure should converge, contrary to fact. I leave this issue unresolved for future research.

⁸⁶ This proposal, of course, opens a whole host of questions, such as what exactly rules out constructions such as *tebja unizhenie*, ('your humiliation'). One possibility is that the pronoun, as a D^0 , must check Case, which is not possible in SpecNP. Another question is why constructions such as *tvoi dom* ('your house') are acceptable. Here, I assume that *tvoi*, as a possessor, is merged in SpecnP (assuming some version of the predicate internal subject hypothesis – otherwise, the possessor is merged even higher, such as SpecDP) rather than in the complement of N^0 . From this position, there is no symmetric c-command between the possessor and possessee.

pronoun here, Babyonyshev offers the data in (97)c and (97)d. These two examples contain a pronoun conjoined with a DP and a pronoun with a DP in apposition, respectively. In both cases, the complement is now a complex phrase, and the sentences are grammatical, showing that a pronoun is possible in these constructions. The problem with (97)a, then, is not the fact that the complement contains a pronoun, but that it contains only a pronoun. The N^0 head and the D^0 head stand in a symmetric c-command configuration, in violation of the LCA.

On a final note, Babyonyshev offers (97)e as evidence for an Antisymmetry account of the data. This sentence contains a “bare” pronoun as a complement, too, but is nevertheless grammatical. The difference, Babyonyshev argues, is that pronouns in the instrumental case are selected by a null preposition.⁸⁷ Thus, the structure for (97)e would appear as follows.

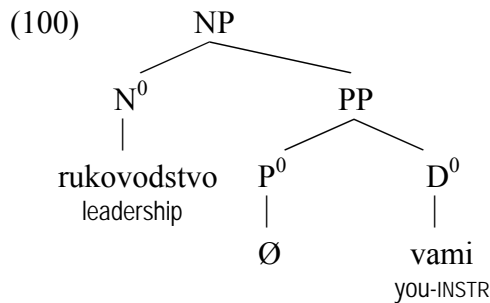

This structure does not violate the LCA, and thus converges at PF.

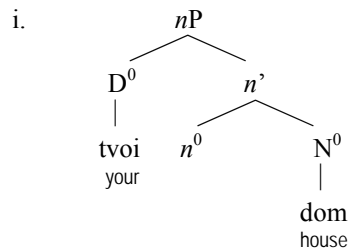

⁸⁷ Babyonyshev actually assumes that all inherent Cases, not just instrumental, are assigned by a null preposition.

The upshot of this discussion is that one possible solution to the Initial Merger Problem is to avoid any structure which would place two heads in a configuration of symmetric c-command. If movement cannot resolve an instance of symmetric c-command created by initial merger of two phonologically specified heads because all possible movements violate some other condition, then all derivations with that starting point will inevitably crash. If such a situation holds generally in a given language, then the only convergent derivations will be those in which initial merger involves on phonologically null head.

2.6. Linearization and Late Insertion

The approach developed so far requires the overt syntactic component of the grammar to treat elements with overt phonological material differently from phonologically null elements. This requires the grammar to be able to distinguish these two types of elements. Under a Distributed Morphology (DM) approach (Halle and Marantz, 1993; Marantz, 1997), lexical items are not inserted into the derivation until after overt syntax. This seems incompatible with the approach taken here, as it gives the overt syntax no phonological material to work with. We will see in this section that the incompatibility can be eliminated through the use of *p-signatures* (Hale and Keyser, 2003).

Hale and Keyser (2003) develop the notion of a p-signature as a marker requiring the insertion of phonological material at PF. The p-signature is a way of letting the syntax know during the course of the derivation where phonologically specified lexical items will eventually appear. If there are two heads in the derivation in a symmetric c-command relation and both of these heads have p-signatures, then PF can determine,

during the syntax, that these two heads will incur an LCA violation at PF, and force movement to take place to resolve this violation. Thus, the analysis presented so far is compatible with a Late Insertion model such as Distributed Morphology, as long as p-signatures are assumed.

Hale and Keyser (2003) also introduce the notion of a defective p-signature in reference to denominal and deadjectival verbs. Let us take as an example the deadjectival verb *thicken*. Hale and Keyser (2003:64) propose the following representations and structures in the derivation of this word.⁸⁸

(101) *Head* *Complement*
 {V, [[Ø]en]} {Adj, [thick]}

(102) {V, [[thick]en]}
 / \
 {V, [[thick]en]} {Adj}

Example (102) shows the process of *conflation* of an adjectival root into a phonologically deficient verbal head to derive the deadjectival verb *thicken*. Hale and Keyser propose that the adjective *thick* has a full p-signature and that the verbal head *-en* has a deficient p-signature. The deficient p-signature attracts the full p-signature of the adjective to the verbal head position, giving rise to the structure in (102). Hale and Keyser propose that conflation as described here must take place under *strict complementation* defined as follows:

(103) *Strict Complementation*

A head X is the strict complement of a head Y iff Y is in a mutual c-command (i.e., sister) relation with the maximal categorical projection of X.

(Hale and Keyser, 2003: 59)

⁸⁸ See Harley (2004) for an explicit analysis of conflation.

Crucially, conflation can take place only under mutual c-command.

Given the facts above on conflation, namely, that a verbal head with a defective p-signature must conflate with a lexical head with a full p-signature, and the theory of phrase structure developed in this chapter, I propose that the distinction between defective and non-defective p-signatures can be dispensed with. Since the two heads that undergo conflation are always in a mutual c-command relation, the proposal here dictates that the complement must raise to the specifier of the head to satisfy the LCA. Thus, there is no need to appeal to the distinction between defective and non-defective p-signatures if we adopt the theory outlined here. A verb such as *thicken*, then, is derived as follows.⁸⁹

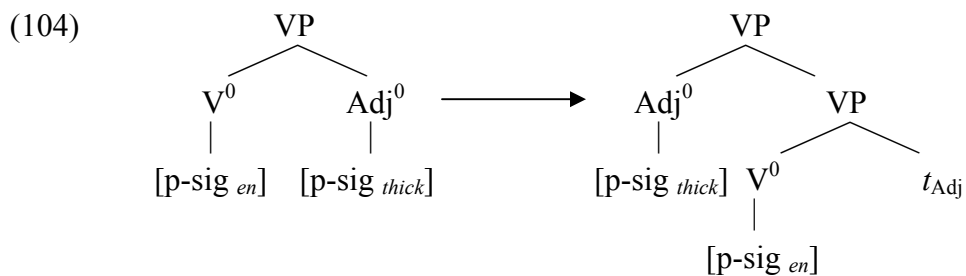

2.7. Summary

This chapter has discussed several previous attempts to reconcile Antisymmetry with Bare Phrase Structure. While many authors have tried to avoid the Initial Merger Problem, I have used it to derive the primary empirical generalization described in Chapter 1. Specifically, incorporated nominal arguments generally appear to the left of the verb, while unincorporated nominal arguments generally appear to the right. I have argued that when a verb merges with a bare noun, the result is an instance of symmetric c-command which is then resolved through movement, as Moro has proposed. The

⁸⁹ This analysis is in line with recent proposals that head movement proceeds by movement of the head to a specifier position, (Matushansky, 2006; Toyoshima, 2000).

central idea here, then, is this: When two heads are merged and both have phonetic content, these two heads form a point of symmetry which is resolved by raising the complement to the specifier position. Each successive merger of a head with phonological content triggers further raising of the complement in a compl-to-spec roll-up fashion. The next chapter discusses noun incorporation in Oneida in detail, and shows how the proposal developed here can account for the data.

3. Oneida Noun Incorporation

The main testing ground for the theory of phrase structure proposed in this dissertation is noun incorporation in Oneida, an Iroquoian language closely related to Mohawk. Oneida is spoken by about 300 people in Oneida-of-the-Thames, near London, Ontario and in Oneida Nation, near Green Bay, Wisconsin. In this chapter, I present a thorough account of noun incorporation in Oneida. I argue that noun incorporation can be thought of as a syntactic process, and that the theory of phrase structure developed in chapter 2 gives an explanatorily adequate account of the data.

This chapter is organized as follows. Section 3.1 briefly describes some properties of clause structure in Oneida. Section 3.2 discusses noun incorporation in Oneida, including incorporation of both standard nominal roots and deverbal nominal roots. Section 3.3 presents an analysis of noun incorporation, showing how the word order follows from the theory of word order proposed here. Section 3.4 presents an analysis of Oneida DPs, and section 3.5 is a summary and conclusion.

3.1. Oneida Clause Structure

In this section, I briefly outline the fundamental characteristics of clause structure in Oneida. The chart in (1) shows the morpheme order for an Oneida verbal complex (Lounsbury, 1949, 1953)⁹⁰ and the corresponding lexical/functional heads I assume correspond with them. I have included incorporated nouns (slot 3) and nominalizers (slot

⁹⁰ The labels ‘mood’ and ‘applicative’ are mine. Lounsbury groups mood morphemes under a larger class called pre-pronominal prefixes, which includes other morphology. Applicative morphemes include benefactive, instrumental and causative.

4) for completeness; however, since noun incorporation is the main focus of this chapter, I postpone the discussion of it until section 3.2.

(1) *Morpheme Order in the Oneida Verbal Complex*

1	2	3	4	5	6	7
mood	pro- nominal prefixes	noun	nom- inalizer	verb	applicatives	aspect
Mood ⁰	Agr ⁰	N ⁰	<i>n</i> ⁰	V ⁰	Appl ⁰	Asp ⁰

The mood morphemes include future, aorist and indefinite markers.⁹¹ The pronominal prefixes are portmanteau morphemes that agree with both subject and object. I leave aside the question how the morphology of pronominal prefixes works in Oneida, assuming a simple AgrP for the purposes of exposition, though this may dangerously over-simplify the situation.⁹² I have placed the nominalizer in the head of a light noun phrase, *nP*, following Kishimoto (2000) and Ogawa (2001). Finally, applicatives have been placed under Appl⁰ following Pykkänen (2002). Following some version of the mirror principle (Baker, 1985) the morpheme order in (1) suggests the phrase structure in (2):⁹³

⁹¹ See Baker and Travis (1997) who argue that the “mood” morpheme encodes verbal definiteness.

⁹² Elsewhere (Barrie, in prep), I propose that the agreement morpheme is actually composed of three independent morphemes that undergo occasional fusion. Briefly, I argue for a π morpheme that agrees with both subject and object, a # morpheme that agrees with either dual or plural on either the subject or object, and an inverse marker that reverses the agent/patient relation between the two participants indicated by the π morpheme.

⁹³ Note that this structure differs slightly from that proposed in (Barrie, 2003).

(2)

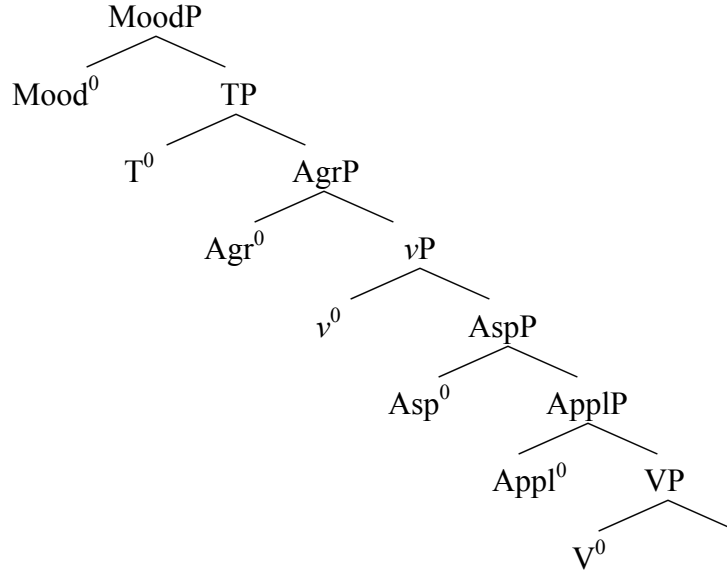

Furthermore, I assume that, as a discourse-configurational language, the overt arguments raise from their thematic positions in the VP-shell to discourse-related A-bar positions in the left periphery (in the sense of Rizzi, 1997). I do not give an analysis of this proposal here, since the facts are still unclear. See Russel and Reinholtz (1997) for a similar analysis for Cree.

This proposal assumes that ApplP represents a high applicative in the sense of Pyllkkänen (2002). Pyllkkänen proposes that high applicatives appear above the VP, while low applicatives appear below the VP. She describes a high applicative as a “thematic relation between an applied argument and the event described by the verb” (Pyllkkänen, 2002: 15).

Morphologically marked applicatives in Oneida include the causative and the benefactive.

(3) wahlúnyahte?

[M&D, 2002]

wah-	1-	uny-	a-	ʔt-	eʔ
FACT-	3.SG.M.NOM-	make-	EPEN-	CAUS-	PUNC
‘He made it out of something.’					

- (4) waʔkheyahyóhalehse? [M&D, 2002]
 waʔ- khe- y- ahy- ohale- ʔse- ʔ
 FACT- 1.SG.NOM.3.SG.F.ACC- EPEN- fruit- wash- BEN- PUNC
 ‘I washed the fruit for her.’

These applicatives relate the event to the applied argument, thus supporting the claim that morphologically marked applicatives in Oneida are high applicatives. The following examples contain low applicatives in the sense of Pylkkänen, which are not morphologically marked.⁹⁴

- (5) wahiʔslehtahni:nú: John [Daisy Elijah, speaker]
 wa- li- ʔslhet- a- hninu- ʔ: John
 FACT- 1.SG.NOM3.SG.M.ACC- car- EPEN- buy- PUNC John
 ‘I bought John’s car.’ OR ‘I bought a car from John.’

In Pylkkänen’s terms, *John* is an argument of a low applicative. That is, John is not related to the event, but is involved in a transfer of possession. The agreement morphology in (5) suggests that *John* is an argument of the verb since it triggers agreement. Furthermore, the following examples support the claim that *John* is an argument of a low applicative, that is, that John is involved in a transfer of possession.

- (6) waʔkhni:nú: John laoʔslehtkʌh [Daisy Elijah, speaker]
 waʔ- k- hninu- ʔ: John laoʔsleht-kʌh
 FACT- 1.SG.NOM- buy- PUNC John his.car-DEC
 ‘I bought the late John’s car.’ OR ‘I bought a car that used to belong to John.’

- (7) *wahihni:nú: John laoʔslehtkʌh [Daisy Elijah, speaker]
 wa- hi- hninu- ʔ: John laoʔsleht-kʌh
 FACT- 1.SG.NOM. buy- PUNC John his.car-DEC
 3.SG.M.ACC-
 (‘I bought the late John’s car.’ OR ‘I bought a car that used to belong to John.’)

⁹⁴ Based on the translations given above, these sentences were originally thought to be examples of possessor stranding. Michelson (1991) shows that this is not the case and argues that the possessor is an argument of the verb.

In the two examples above, John is not involved in a transfer of possession, and thus is not an argument of a low applicative. This is because John is either dead, or no longer owns the car. Accordingly, *John* does not trigger agreement on the verb as the grammaticality of (6) and the ungrammaticality of (7) show.

To summarize, Oneida high applicatives are morphologically marked and appear in the clausal structure as shown in (3) and (4). Low applicatives in Oneida, however, are not morphologically marked. We return to the structure of low applicatives later.

Turning now to aspect, the structure in (2) represents aspect as inner aspect in the sense of Travis (1991). Travis notes that some intriguing relationships between aspect and the direct object fall into place if the structure includes an inner aspect phrase. In particular, she relates inner aspect to completedness. Independently, Kratzer (2004) draws a strong connection between telicity and accusative Case. In earlier work (Barrie, 2003), I capitalized on Kratzer's insights and proposed an analysis of pronominal marking in Iroquoian that relates telicity or boundedness⁹⁵ to accusative Case. First, Dyck (1992) observes that, for a closely related language, Cayuga, accusative Case marking is available only when the event is telic. I extend this observation to stage- and individual-level predicates. Individual-level predicates appear with nominative Case, while stage-level predicates appear with accusative Case.

- (8) wakatiwΛ⁹⁶ [Michelson & Doxtator, 2002]
 wak- atiwΛ- Ø
 1.SG.ACC- buy- STAT
 'I am thin.'

⁹⁵ I remain agnostic here as to whether telicity or boundedness (in the sense of Depraetere, 1995) is the more appropriate choice. We will see in the next few paragraphs, that the standard definition of telicity is not quite right for the situation here.

⁹⁶ Evidence that *atiwΛ* is a stage level predicate comes from the Oneida forms for 'I will be thin' and 'I was once thin.'

- (9) khnΛ:yés [Michelson & Doxtator, 2002]
 k- hnΛyes- Ø
 1.SG.NOM- be.tall- STAT
 ‘I am tall.’

In Barrie (2003), I argued that the relevant property here is telicity or boundedness. Specifically, I argued that since individual-level predicates represent an inherent, unchanging characteristic of their subjects, individual-level predicates are atelic or unbounded. Conversely, since stage-level predicates represent a temporary or changeable characteristic of their subjects, stage-level predicates can be thought of as telic or bounded. Note carefully that the definition of telicity here differs significantly from the standard definition of telicity. Traditionally, a telic property is one which has an inherent end-point, while an atelic property has no inherent end-point (although it may end). Thus, *Mary swam 5 kilometres* has an inherent end-point, while *Mary was swimming* has none. There is nothing about this sentence, however, that implies that Mary will never stop swimming. Rather, the atelicity simply refers to the lack of an inherent end-point. In the situation here, I have used the term atelic or unbounded to refer to the obligatory lack of any end-point, while telic or bounded refers to the absence of this restriction – that is, a telic state may continue indefinitely, but it doesn’t have to.

The same distinction also arises with alienable and inalienable possession. Alienable possessed nouns are marked with accusative Case and inalienably possessed nouns are marked with nominative Case.

- (10) laoʔshaleʔ [Daisy Elijah, speaker]
 lao- ashal- eʔ-
 3.SG.ACC.M.POSS- knife- NFS-
 ‘his knife’

- (11) knutsine [Daisy Elijah, speaker]
 k- nusti- ne-
 1.SG.NOM.POSS- head- LOC-
 ‘on my head’

Again, I argued in Barrie (2003) that alienability implies the lack of the possibility of a temporal end-point, while inalienability implies the lack of any possible end-point. Thus alienable possession is telic or bounded since there can be an end-point, while inalienable possession is atelic or unbounded since there cannot be an end-point.

Given the relation between telicity or boundedness and the internal argument (made explicit by accusative Case marking in Oneida), I assume an inner aspect phrase in the sense of Travis; that is an aspect phrase where completion is encoded.

This brief section has introduced the clause structure that I assume for Oneida. In particular, I have suggested that Oneida has low applicatives and inner aspect. We are now ready to undertake an analysis of noun incorporation within an Antisymmetric framework without head-movement.

3.2. Patterns of Noun Incorporation in Oneida

Noun incorporation is highly productive in Iroquoian languages, but is subject to many restrictions involving both verbal and nominal roots. As for verbal roots, there are many which must incorporate, many which optionally incorporate and many which cannot incorporate. Likewise for nominal roots, there are many which must be incorporated, many which optionally incorporate and many which cannot undergo incorporation. I will concentrate on the variation found among verbal roots in the upcoming section, and then turn to nominal roots.

Noun incorporation has been the subject of a long-standing debate in the literature on noun incorporation. Many authors have argued that noun incorporation is a lexical process (Di Sciullo and Williams, 1987; Mithun, 1984, 1986; Rosen, 1989). Others have argued for a syntactic analysis (Baker, 1988, 1993, 1996; Baker *et al.*, 2005; Hale, 2001; Sadock, 1980, 1985, 1986; Wiltschko, 2002). One of the main arguments for a lexical treatment of noun incorporation in Iroquoian is its putative lack of productivity. I show below that much of the apparent lack of productivity of noun incorporation in Iroquoian can be explained by independent factors in the language. I assume here that noun incorporation is a syntactic process.^{97,98}

3.2.1. *Verbal Roots*

3.2.1.1. Obligatory Incorporation

The following example lists several verbal roots that obligatorily trigger incorporation in Oneida (M&D2002):⁹⁹

(12) *Verbal Roots in Oneida*

a-	to grab a body part
aksΛ-	to be bad, not the way it should be
atatyε-	to be extended along
εs-	to be a duration in time
Λht-	to drop, let fall ¹⁰⁰

⁹⁷ It is interesting to note that the argument of whether noun incorporation is syntactic or lexical evaporates under a Distributed Morphology approach (Halle and Marantz, 1993; Marantz, 1997) since under such an approach morphologically complex structures are not formed in the lexicon. Under a DM approach, then, the discussion becomes whether noun incorporation is syntactic or morphological. I do not pursue this line of thought here. Note further that an approach along the lines of Julien (2002) would claim that noun incorporation must be syntactic as she proposes that all morphology is done in the syntax.

⁹⁸ See also Li (2005), who argues for an intermediate approach that includes both a lexical and syntactic approach to word formation.

⁹⁹ Many of the examples in this chapter are taken from Michelson and Doxtator (2002). Data from this source is marked as [M&D2002]; data from my own field work with Daisy Elijah are marked [Daisy Elijah, speaker].

at-N ¹⁰¹ -hsluni-	to dress, prepare, trim, fix up.
at-N-ik	to fill up completely
at-N-kalatat	to raise up, lift up for oneself
at-N-kehlu-	to put things here and there for oneself

The following pair of examples illustrates that noun incorporation is obligatory for these verbs:

(13) *noun incorporation with a-* ('to grab a body part') [M&D2002]

- a. waʔshakohnyá:saʔ
waʔ- shako- hnyaʔs- a- ʔ
FACT- 3.SG.M.NOM.3.SG.F.ACC- neck- grab- PUNC
"He put his arms around her neck."
- b. *yenyalá:ke wa:shákoʔ
ye- nyal-ake waʔ- shako- a- ʔ
3.SG.F- neck-LOC FACT- 3.SG.M.NOM.3.SG.F.ACC- grab- PUNC
"He put his arms around her neck."

This class of verbs is quite small, and the overwhelming majority of verbs in this class appear with a semi-reflexive marker */-at/*, which precedes the incorporated noun, as shown in (14). Of the verbs which take the semi-reflexive */-at/*, some must appear with both the semi-reflexive marker and an incorporated noun, while others appear optionally with the semi-reflexive marker, in which case noun incorporation is also optional. In all cases, if the semi-reflexive marker is present, noun incorporation is obligatory. The following examples illustrate both of the possibilities.

¹⁰⁰ The morphosyntax of this verb is actually quite complex. In the form given (root *A-* with causative a suffix *-hi*) this verb must incorporate, often giving rise to non-compositional or idiomatic meanings. With translocative or cislocative morphology, this verb is free to incorporate or not.

¹⁰¹ The capital 'N' in the glosses indicates the position of the incorporated noun when the noun is not in initial position.

(14) teyothnekato:té: [Daisy Elijah, speaker]
 te- yo- at- hnek- atote- ´:
 DUAL- 3.SG.N/F¹⁰².ACC- SREFL- liquid- be still- STAT
 “The water is still.”

(15) *teyohnekato:té:
 te- yo- hnek- atote- ´:
 DUAL-3.SG.N/F.ACC- liquid- be still- STAT

(16) *teyoto:té:
 te- yo- atote- ´:
 DUAL-3.SG.N/F.ACC- be still- STAT

With this verb, the semi-reflexive marker is necessary, and noun incorporation is obligatory. Some verbs, though, may appear without a semi-reflexive marker, in which case noun incorporation is optional.

(17) wa?ewisaka:látate? [Daisy Elijah, speaker¹⁰³]
 wa?- ye- wis- a- kalatat- e?
 FACT- 3.SG.F.NOM- ice/glass- JOIN- raise- PERF
 “She raised the window.”

(18) wa?ehalá:tate? owishe?
 wa?- ye- halatat-e? o- wis- e?
 FACT- 3.SG.F.NOM- raise- PERF 3.SG.N-ice/glass- NFS
 “She raised the window.”

(19) wa?katwisakalá:tate?
 wa?- k- at- wis- a- kalatat- e?
 FACT- 1.SG.NOM- SRFL-ice/glass- JOIN- raise- PERF
 “I raised my window up.” or “I raised the window up for myself.”

(20) *wa?katkalátate? owishe?
 wa?- k- at- kalatat-e? o- wis- e?
 FACT- 1.SG.NOM- SRFL-raise- PERF 3.SG-ice/glass- NFS

¹⁰² There are two feminine gender markers in Oneida. In this paper, I use the terms ‘neuter/feminine’ (‘feminine-indefinite’ in the Iroquoian literature) and ‘feminine’ (‘feminine-zoic’ in the Iroquoian literature). The sociolinguistics of their distribution with respect to human reference is quite complex; however, the neuter/feminine marker is used for someone of unknown gender and the feminine marker is used for animals and some inanimate objects (Abbott, 1984).

¹⁰³ The underlining in the Oneida examples indicates that that portion of the word is whispered. This phenomenon occurs in phrase-final position.

In examples (17) and (18), we see that noun incorporation is optional with the unaugmented root *-kalatat-* (“raise up”). In examples (19) and (20), however, the semi-reflexive morpheme is present, and noun incorporation must take place. The semi-reflexive marker has the semantic effect of either what one may call a “reflexive benefactive” (to do something for oneself) or to show ownership of the object. The inherent ambiguity of this marker is shown by the two readings given in example (19).

Thus it appears that with a few exceptions it is the presence of a benefactive semi-reflexive that forces noun incorporation for these verbs.¹⁰⁴ In other words, if the semi-reflexive marker is present on these verbs, noun incorporation must take place. At the moment, I have no explanation for the fact that the benefactive semi-reflexive makes noun incorporation obligatory. What is important is that, except for a handful of roots, obligatory noun incorporation is not a lexical property of the verbal root, but rather a property of the semi-reflexive marker. Recall that for some of these verbs the semi-reflexive marker is obligatory. This does not affect the generalization just noted that it is the presence of the benefactive semi-reflexive that forces noun incorporation.

Related to this class is a set of verbs that must appear with a dummy noun in the unincorporated form. Unlike the verbs in example (12), which must incorporate a semantically specified noun, the verbs listed below must incorporate a dummy noun if no full noun is incorporated. Thus, in contrast to the verbal roots in (12), which require a lexical nominal root, the following verbal roots merely require something of category [N] – either a lexical nominal root or a dummy noun.

¹⁰⁴ The first five entries in example (12) are the only obligatorily incorporating verbs listed in all of Michelson and Doxtator (2002) that do not appear with the semi-reflexive marker.

(21)	dummy noun	verb stem	translation	[M&D2002]
	ʔlh-	olok-	to cover up	
	ʔsk-	o-	to be in water	
	aʔs-	ʌʔ-	to fall, drop	
	aʔt-	aʔek-	to pound the surface	
	hnaʔ-	net-	to be doubled; insulated	
	n-	ohale-	to wash	
	y-	ʔsel-	to stack/pile	

(22)	keʔlho:lóks				[M&D2002]		
	k	e	<table border="1" style="display: inline-table; vertical-align: middle;"><tr><td>ʔlh</td></tr><tr><td>DN</td></tr></table>	ʔlh	DN	olok	s
ʔlh							
DN							
	1.SG.NOM	EPEN		cover.up	HAB		
	“I’m covering it up.”						

(23)	kheʔlho:lóks					
	khe	<table border="1" style="display: inline-table; vertical-align: middle;"><tr><td>ʔlh</td></tr><tr><td>DN</td></tr></table>	ʔlh	DN	olok	s
ʔlh						
DN						
	1.SG.NOM.3.SG.F.ACC		cover.up	HAB		
	“I’m covering her up.”					

(24)	waʔkhekʌho:lókeʔ				
	waʔ-	khe-	kʌh-	olok-	eʔ
	FACT-	1.SG.NOM.3.SG.F.ACC-	blanket-	cover.up-	PERF
	“I put a blanket over her.”				

Examples (22) to (24) show that the verbal root *-olok-* (“cover up”) incorporates a lexical nominal root (as in example (24)), or, if no lexical nominal root is available, it incorporates a dummy nominal root (as in examples (22) and (23)).

Although a full explanation of the syntax of dummy nouns cannot be undertaken here, it is clear that dummy noun insertion cannot be a semantically driven process, since the dummy noun does not contribute any meaning to the sentence. Rather, there appears to be some syntactic requirement of noun incorporation for these verbs.

3.2.1.2. Optional Incorporation

By far the largest class of verbs in Oneida consists of those that optionally take incorporated nouns, unergatives notwithstanding.¹⁰⁵ The fact that this class of verbs is so large suggests that noun incorporation is a productive process, and not lexically constrained. Example (25) lists several verbs that optionally trigger noun incorporation:

(25)	a-	to be a certain size	[M&D2002]
	ahluk-	to hear about	
	akʌl(e)-	to be scarce	
	(a)klaʔ-	to smell, stink	
	anuhyaniht-	to be dirty	
	ashet-	to count	
	awi-/u-/ʌ-	to give	

The possible forms, with and without noun incorporation, are shown in (26) and (27).

(26) noun incorporation with *awi-/u-/ʌ-* 'to give' [M&D2002]

a. kuyawíheʔ

kuy-	awi-	heʔ
1.SG.NOM.2.SG.ACC-	give-	HAB

"I give it to you."

b. waʔukhwístuʔ

waʔ-	uk-	hwíst-	u-	ʔ
PST-	3.SG.N/F.NOM.1.SG.ACC-	money-give-	PERF	

"She/someone gave me money."

(27) a. waʔtyakyata:tú:

waʔ-	te-	aky-	atat-	u-	':
PST-	DUAL-	1.DU.EXCL.NOM-REFL-	give-	PERF	

"We two(excl) traded."

¹⁰⁵ Unergatives, of course, have no internal arguments; only an external argument. This large class of verbs never exhibits noun incorporation since there is no internal argument to incorporate.

b. tatyatatnawi:lú:

te- ʌ- tya- atat- nawil- u- ' :
 DUAL- FUT- 1.DU.INCL.NOM-REFL- tooth- give- PERF
 "You and I will trade teeth."

3.2.1.3. Non-incorporating Verbal Roots

Finally, there are said to be verbs that prohibit noun incorporation. Let us first consider the status of this class. Mithun and Corbett (1999) have used the existence of such verbs in Iroquoian to argue against a syntactic account of noun incorporation. The logic of this argument is that if incorporation is a syntactic process, then all verbs, except unergatives, should be able to take incorporated nouns. If noun incorporation exhibits varying degrees of applicability depending on the choice of verb, then it is more likely to be a lexical process. However, many of the verbs that cannot take incorporated nouns are in complementary distribution with roots that obligatorily incorporate. Several such pairs are given in (28).

(28) *Incorporating and non-incorporating verbal roots in Oneida*

incorporating root	non-incorporating root	translation [M&D2002]
aksʌ-	hetkʌ-	to be ugly
kaleny-	aleny-	to disperse
isak-	ehsak-	to look for
aty-	uty-	to lose, leave
kaʔ-	ekaʔ-	to like the taste of
ihal-	hal-	to hang up
kalatat-	halatat-	to lift up, raise

I would like to suggest that noun incorporation is not constrained by the choice of verb as suggested by Mithun and Corbett (1999), but rather that these verbs have two allomorphs. Which of the two allomorphs is inserted depends on the context. This mirrors English in the choice of root for the words *destroy* and *destruction*. The root *destroy-* is

inserted in verbal contexts and *destruct-* is inserted in nominal contexts. Likewise in Oneida, *aksA-* (“to be ugly”) is inserted in contexts when a noun is incorporated and *hetkA-* (“to be ugly”) is inserted otherwise.¹⁰⁶

If this is correct, then noun incorporation can be treated as a syntactic process generally available to all non-unergative verbs, rather than as a lexical process with different degrees of applicability, where some verbs are lexically specified not to allow incorporation, some are lexically specified to optionally allow it, and others are lexically specified to require it. Apparent exceptions to this generalization can be explained independently. As just shown, many verbal roots that must undergo incorporation are allomorphs of verbs that optionally take incorporated nouns, but surface in a different form when no noun is incorporated. The remaining verbal roots that must undergo incorporation, which do not have a non-incorporating counterpart, can be divided into two groups. The first group, which is the smaller group, are taken to be light verbs in the sense of Johns (2003). Such verbs do not constitute a lexical root and must therefore, incorporate a nominal lexical root.¹⁰⁷ The larger group of obligatorily incorporating verbal roots all appear with a semi-reflexive marker that gives rise to a reflexive benefactive interpretation. When the semi-reflexive marker does not appear on the verbal root, noun incorporation is not obligatory. It is thus the semi-reflexive marker which, for unknown reasons, makes incorporation necessary.

¹⁰⁶ Forms such as these provide strong support for late insertion, since the choice of root is dependent on context.

¹⁰⁷ Note that the class of verbs that I am claiming are light verbs is not semantically equivalent to the set of verbs that Johns (2003) claims to be light verbs.

3.2.2. Nominal Roots

The majority of nominal roots are free to undergo noun incorporation into a verbal structure or appear as free-standing DPs in Oneida, so I will not mention them here. There are many nouns that cannot incorporate into a verbal root for various morphological reasons, which I discuss next. There is also a small set of nouns that must incorporate, which I discuss last.

Oneida nouns that cannot incorporate fall into two categories. First, there are bare atomic nouns such as *kóskos* (“pig”) which cannot take any inflectional morphology, as a regular Oneida noun does. Such nouns are semantically no different from standard nouns that obligatorily appear with a prefix and a suffix. That is, they are referential and can appear with determiners as standard nouns can. Thus, they are full DPs – they are not bare in the sense that they are only an N^0 . They are bare in the sense that they do not appear with standard nominal morphology. I suggest pending further research that nouns of this type can be spelled-out only as a full DP, and that there is no bare nominal root that can be extracted. The following examples illustrate this point. Note that these figures are just for illustrative purposes only. The more detailed discussion on the structure of nouns is presented near the end of this chapter. In the following trees, FP and GP are functional projections within the extended DP.

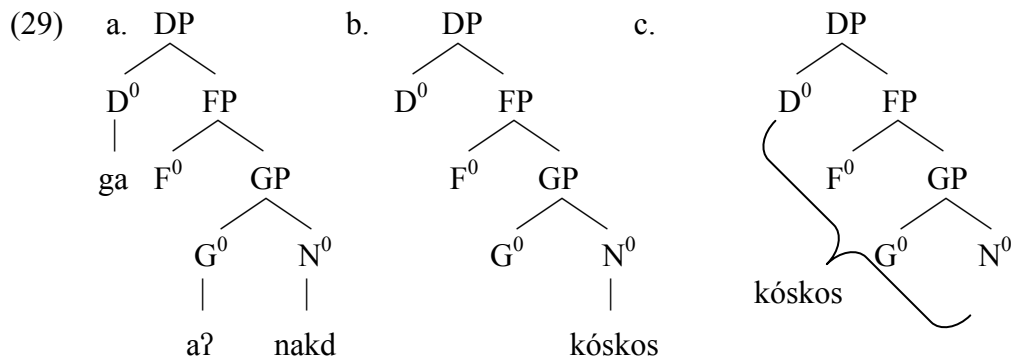

(29)a. shows the derivation for *ga-nakd-aʔ* ('bed'), which consists of a prefix, *ga* the root, *nakd*, and a suffix, *aʔ*. If we assume the root raises to the left past the suffix, we get the surface morpheme order as shown. If we were to assume that nouns such as *kóskos* are nominal roots like any other, except that the prefix and suffix appear as null allomorphs, as in (29)b, then we would be at a loss to explain why such nouns cannot undergo incorporation into verbal roots. Instead, I propose something along the lines of (29)c, in which nouns such as *kóskos* always spell out an entire DP. There is thus no bare N^0 that can be extricated for use in a noun incorporation structure.

There are also nouns that are derived from entire Oneida sentences such as *kaya ʔáklaseʔ* ('goat', lit. 'its body stinks'). These words must appear fully inflected with verbal morphology in order to function as a noun. Thus a bare root cannot be extracted to participate in noun incorporation. In both cases, there is no semantic reason to bar these nouns from participating from noun incorporation. Also, the fact that they cannot incorporate does not need to be relegated to the lexicon, since their failure to participate in this process can be explained by morphological factors.

Next, I discuss a small set of nouns that must undergo noun incorporation into a verbal root. These are listed in example (30).

(30) *Obligatorily-incorporating nominal roots*

-ahsakʌsl	frost	[M&D2002]
-ahuhs-	sense of hearing	
-atshat-	fog, steam	
-elyʌʔt-	intention, purpose	
-nut-	hill	
-ohsl-	year	
-oʔkw-	round object	
-unh-	life	

Note, however, that the nominal roots in example (30) are not freely occurring, and many of them appear in only a few words. Seen in this light, these roots are like English bound roots such as */-ceive/*, in that they appear only in a small handful of words such as the one in (31).

(31)	okahló:kwaʔ	[M&D2002]
	o- kahl- oʔkw- aʔ	
	3.SG.FZ- eye- round.object NFS	
	“eyeball”	

It is likely, then, that words such as those in example (31) are lexically listed, however they form a small fraction of the set of nouns that can undergo noun incorporation into a verbal root.

There is yet another class of roots that do undergo obligatory noun incorporation into a verbal root. Each of these nominal roots, listed in (32), has an allomorph that appears in non-incorporating contexts.

(32) *Nominal roots in complementary distribution*

incorporating root	non-incorporating root	translation[M&D2002]
-naskw	-tshenΛ	animal
-nyey	-nyΛht	snow
-atsyΛ	-ks	dish

Thus, like the verbal roots in (28) above, some nominal lexical items exhibit allomorphy depending on whether they are incorporated.

In this section I have shown that the varying ability of verbal and nominal roots to participate in noun incorporation structures is only illusory. Most verbal and nominal roots may participate in noun incorporation, but are not required to. When noun incorporation is required or disallowed, there are independent morphological reasons for

the lack of choice, and a lexical item's ability to participate in noun incorporation does not need to be listed in the lexicon directly. I shall therefore assume that noun incorporation in Oneida is a syntactic process.

3.3. Analysis

3.3.1. Previous Analyses

Noun incorporation in languages like Oneida has sometimes been analyzed as a lexical process, and sometimes as a syntactic process. Since I am adopting a syntactic approach given the evidence discussed in the previous section, I review here three previous syntactic accounts of Iroquoian noun incorporation, showing where the analyses are incompatible with the theoretical framework developed here, that is Dynamic Antisymmetry, Bare Phrase Structure, and no head-movement.

Baker (1988; 1996) undertook a comprehensive cross-linguistic study of noun incorporation, which included a discussion of Mohawk. He proposes that the head of a bare NP moves alone to incorporate into the verb:

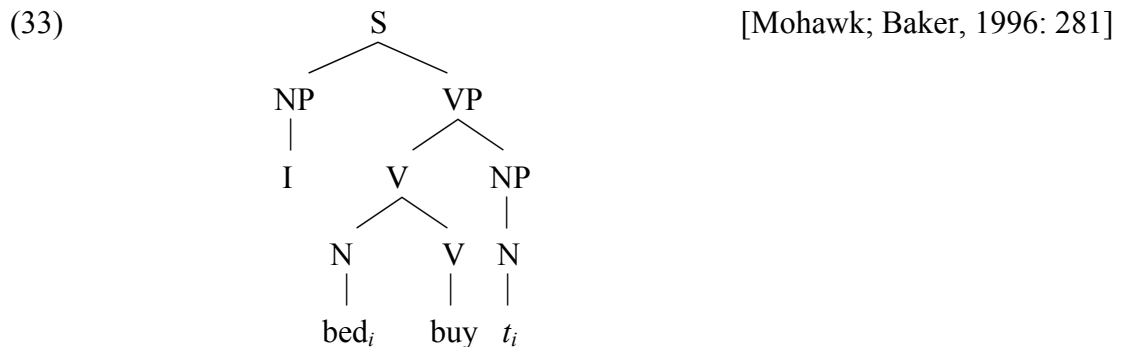

In example (33), English words have been used in place of the Mohawk, as in Baker's original example. In Baker's view, noun incorporation takes place because the verb in

Mohawk must discharge its θ -role to an element internal to the verb.¹⁰⁸ Under the assumptions being made here, head-movement is unavailable, and the movement of the head noun of the direct object will therefore have to be re-analyzed as phrasal movement. Second, the structure in (33) does not follow general principles of Bare Phrase Structure, because the object NP is a non-branching projection. Since syntactic structure under Bare Phrase Structure can be built only by Merge, non-branching structures cannot be created.

Wiltschko (2002), following Sportiche (1996; 1998) and Lin (2000), assumes a version of the split DP hypothesis, which can account for the complementarity of noun incorporation and agreement marking without appealing to Baker's (1996) Polysynthesis Parameter. Under the Split DP Hypothesis, DPs are formed discontinuously as in (34).

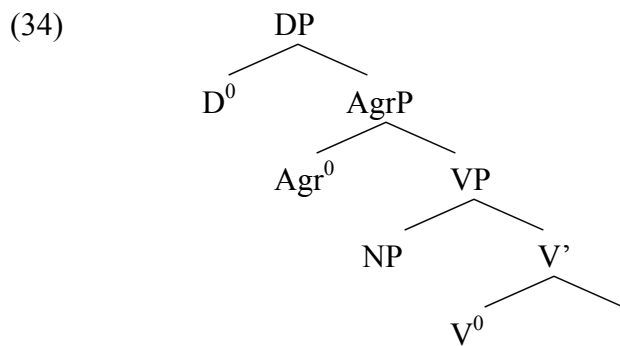

Thus, in a sentence such as *the boy slept*, the NP *boy* raises from under VP to somewhere in DP to be licensed by D^0 . Wiltschko assumes that for Mohawk, DP and AgrP are collapsed into a single head. The lack of a pure DP independent of AgrP explains the lack of overt determiners in Mohawk and related languages. Wiltschko gives the Mohawk

¹⁰⁸ This is the essence of Baker's (1996) Polysynthesis Parameter – that all θ -roles must be discharged to a morpheme internal to the word that assigns the θ -roles. I will not be concerned directly with theoretical status of the Polysynthesis Parameter here, although I do show an alternative approach to the difference in availability of noun incorporation in Oneida and English in the conclusion. Specifically, I show that language-internal properties can be shown to be responsible for the lack of noun incorporation in English rather than having to appeal to macro-parametric variation.

sentence in (35) the structure in (36), where NP is the noun *ka-nakt-a* (“bed”). We leave aside, for the moment, the distinction between subject and object agreement.

- (35) wa- k- nhinu-’ ne ka-nakt-a
 FACT- 1SS- buy- PUNC NE NSS-bed-NFS
 “I bought the/a bed.”

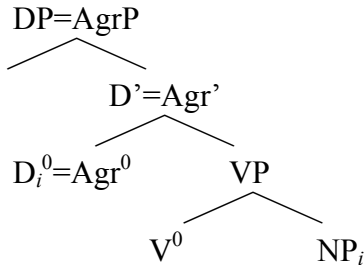
- (36)  [Wiltschko, 2002, ex. (6)]

Unlike languages such as English and French, Mohawk can delay movement of the NP to the specifier of DP until LF. This delay gives the observed word order, with the NP to the right of the verb.

Noun incorporation takes place when there is no DP/AgrP projection above VP. The bare noun does not have a licensing position to raise to at LF and must incorporate into the verb. A consequence of this explanation is that it obviates the polysynthesis parameter, so that the differences between languages can be captured by setting various microparameters.¹⁰⁹ It also introduces very little new machinery to UG, making use of independently existing operations.

However, there are some technical problems with the analysis. Wiltschko states that the VP-internal NP is bare, since the determiner element is in the head of DP, outside VP. However, determiner morphemes may appear on full, unincorporated NPs, as shown in (37).

¹⁰⁹ See (Legate, 2002) for a microparametric approach to non-configurational languages.

- (37) wahihninú: laó:slet [Daisy Elijah, speaker]
 waʔ- li- hninu- ʔ: lao- ʔsleht
 PST- 1.SG.NOM.3.SG.M.ACC- buy- PERF his- car
 “I bought his car.” or “I bought the car from him.”

Here, overt determiner morphology – the possessive marker /*lao-*/ = ‘his’ appears on the unincorporated nominal. This is inconsistent with the proposal that VP-internal arguments are bare NPs. There is also morphology that is arguably a D^0 head in the example that Wiltschko provides in (35): the morpheme /*ka-*/, which she glosses as NSS (neuter singular subject). Another problem is the co-indexing of NP and D^0 in (36). These two elements are not, in fact, related. The NP is the direct object, the bed, and D^0 is the subject of the sentence, the speaker. It is not clear, then what triggers LF raising of NP to D^0 , since the two elements do not seem to share any features. Wiltschko’s account has one further problem in the context of our approach.¹¹⁰ If the verb in (36) has merged with a bare noun, Bare Phrase Structure dictates that the nominal should be a head, not a phrasal projection. Clearly, this analysis is built in an X-bar-Theoretic framework. Thus, it is unclear from Wiltschko’s discussion whether incorporation takes place via XP-movement or head-movement.

Hale (2001) argues that nouns are merged in their incorporated position and noun incorporation involves no syntactic movement *per se*. Crucially, Hale’s analysis is syntactic and not lexical, since the incorporated nouns are merged in the syntax. Hale argues that neither a pronominal argument nor a bare nominal (the kind found in incorporating structures) needs to raise out of VP for Case or to satisfy some EPP requirement on a higher functional head. They are licensed *in situ*. Thus, noun

¹¹⁰ Note that these problems are not necessarily insurmountable and that Wiltschko’s analysis may be able to be reconfigured to deal with them.

incorporation boils down to the bare nominal remaining in its merged position rather than raising out of the VP. Hale discusses the following example:

- (38) Wa'-ka-wír-v'-ne' [Hale, 2001 (cited from Baker, 1996: 293)]
 FACT-NsS-baby-fall-PUNC
 "The baby fell."

The overt nominal *wír* ('baby') in (38) is the subject of an unaccusative verb. As such, Hale states that, by hypothesis, it originates in the specifier of the verbal projection.¹¹¹

Hale's discussion suggests that he had in mind a structure like (39).

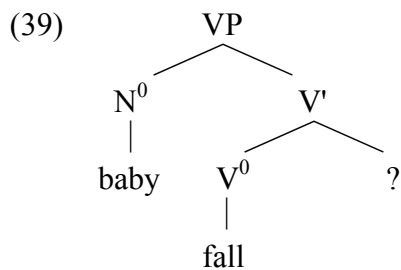

This structure is problematic under a Bare Phrase Structure approach (Chomsky, 1994). In Bare Phrase Structure, the verb and the noun merge to form the structure in example (40):

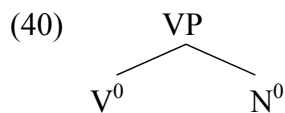

In fact, it is impossible to have an argument in [Spec., VP] as in example (39) without some element first merging in complement position. Furthermore, it is unclear exactly how an incorporated object, which would presumably originate as the complement of V, would appear to the left of the verb under this analysis. However, the approach advocated here can deal with this problem quite nicely if we assume that the verb and the nominal head are merged as in (40). Antisymmetry then forces the nominal head to raise to the

¹¹¹ Hale does not give any justification for placing the unique argument of an unaccusative in the specifier of VP.

specifier of VP, giving rise to the structure in (41), which is for all intents and purposes identical to (39).

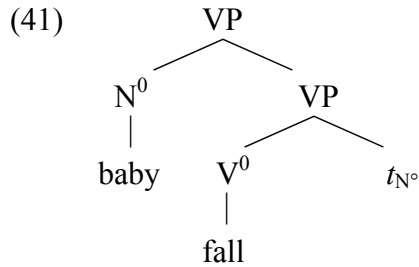

I have reviewed three accounts of noun incorporation in Iroquoian and have concluded that none of these accounts offers a fully satisfactory analysis of noun incorporation that respects Bare Phrase Structure and excludes head-movement, although Hale’s analysis is on the right track. The following section develops just such an analysis.

3.3.2. *Noun Incorporation as Phrasal Movement*

Following Baker (1988; 1996) *inter alia*, I assume that noun incorporation is syntactic. I depart from Baker’s analysis, however, in one very important aspect. While Baker assumes that head-movement is a permissible operation in UG, the framework I adopt here does not allow this. Noun incorporation must therefore be recast as phrasal movement. In the rest of this section, I develop an Dynamic Antisymmetric, phrasal-movement account of noun incorporation in Oneida. I begin with the incorporation of deverbial nouns, followed by the incorporation of standard nouns.

3.3.2.1. The Incorporation of Deverbial Nouns

Since noun incorporation moves a bare noun into a verb, as opposed to a fully inflected noun, there is an intuitive appeal to the head-movement approach. There is, however, evidence that something larger than a bare root can incorporate into the verb,

suggesting that incorporation in fact involves phrasal movement. The situation in question involves incorporation of a deverbal noun. When a deverbal noun is incorporated into a verb, it typically appears with what has been called a nominalizer affix (Lounsbury, 1949, 1953).

- (42) waʔutokwaʔtslóhaleʔ [M&D2002]
 waʔ u atokw a ʔtsl ohale ʔ
 PST 3.SG.F.NOM take.out.of.water JOIN NZLR wash PERF
 ‘She washed the spoon.’

Example (42) shows the deverbal root *okw* and its nominalizer *ʔtsl* incorporated onto the verb *ohale*. The joiner vowel is inserted epenthetically to satisfy phonotactic constraints of the language, and plays no role in the syntax.¹¹² Example (36) shows several more examples of deverbal roots with their nominalizers.

(43)	Root	Nominalizer	Translation of nominalized form
	-atku	ʔsl	snake
	-atlahti	ʔtsl	sock
	-atle	ʔsl	grandchild
	-atnutekt	ʔtsl	lid, cover
	-atshanunya	hsl	happiness
	-atsheyalʌ	hsl	shyness
	-atyanlu	hsl	ghost

¹¹² Evidence that the joiner vowel plays no role in the syntax comes from the fact that, like other epenthetic vowels, it does not affect stress assignment. If stress assignment is handled at PF, after syntax, the joiner vowel must therefore not appear until well into the PF component of the grammar. Furthermore, the joiner vowel appears only in cases where the N+V sequence would create an illegal consonant cluster.

-atyaʔtawiʔt	ʔtsl	dress, shirt, jacket, coat, blouse
-aʔnhaluk	hsl	rope
-aʔnuk	hsl	onion

The nominalizer affix generally appears only when the root incorporates into the verb, but sometimes appears in other contexts as well.¹¹³

Assume, following Ogawa (2001), that the first extended projection of NP is a light noun phrase *nP*, which hosts the nominalizer.¹¹⁴ When the nominalizer and the bare root merge, they are in a symmetric c-command relation as shown in (44).

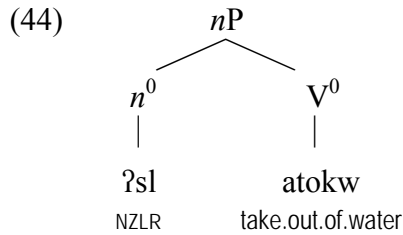

The symmetry in example (44) arises from the fact that the bare verb is simultaneously a minimal and maximal projection. This is an inevitable consequence of first merge, since first merge always involves two heads, of which only one projects. The symmetry is eliminated by raising V^0 to [Spec., *nP*] as shown in (45).

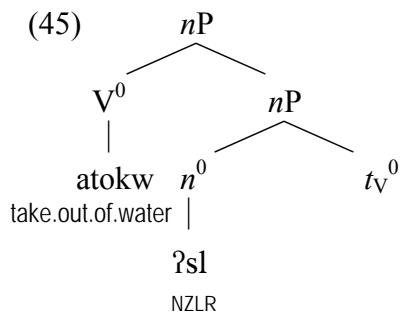

At this point, the *nP* may merge with a verb (labelled as V_1 for exposition):

¹¹³ Most commonly, the nominalizer appears between the root and a locative suffix, which has led to the suggestion that the locative affixes are incorporating verbs (Baker, 1988). In a few rare cases, the nominalizer appears in all nominal forms. In those cases, I assume the verbal root and nominalizer together form a single root that has been reanalyzed as a nominal root.

¹¹⁴ Ogawa (2001) actually refers to this projection as a nominalizer phrase (NzP). I use the term light noun phrase (*nP*) following Marantz (2001).

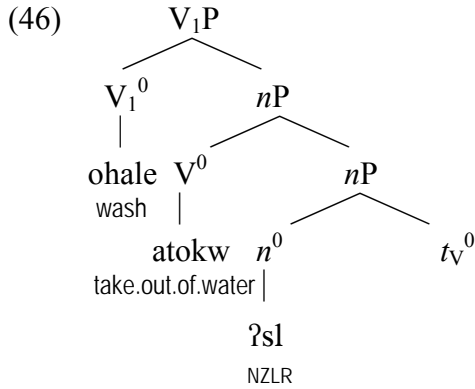

Now, V_1^0 and V^0 are in symmetric c-command relation, since V^0 is not dominated by nP . nP therefore raises to Spec V_1P to resolve this symmetry:

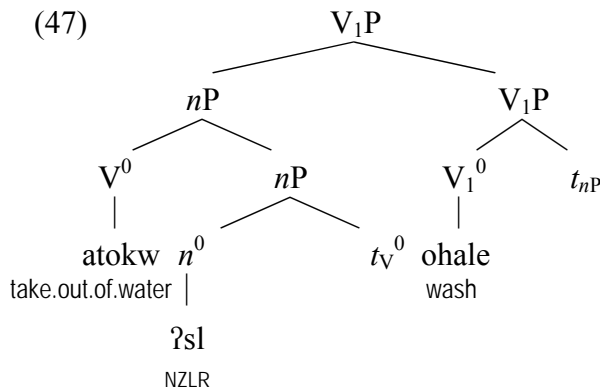

In (47), nP asymmetrically c-commands V_1^0 , thus V^0 and n^0 are ordered before V_1^0 by the LCA. Furthermore, V^0 asymmetrically c-commands n^0 , so V^0 is ordered before n^0 by the LCA. At this point we have derived the correct morpheme order for the sentences in (42), a typical noun incorporation structure found in Oneida.¹¹⁵ Specifically, the incorporated nominal root precedes the nominalizer, which in turn precedes the verbal root. We will continue with the derivation of the remainder of the clause later, but first, let us consider the incorporation of nominal roots.

¹¹⁵ Baker's (1996) Morphological Visibility Condition originally accounted for the complementarity of agreement and noun incorporation in Mohawk, about which the current proposal has nothing to say. In more recent work, however (Baker *et al.*, 2005), examples of noun incorporation are discussed where the verb agrees with the incorporated noun. The current proposal is compatible with both types of noun incorporation, leaving the difference to fall out from other aspects of the grammar.

3.3.2.2. The Incorporation of Nominal Roots

By nominal roots, I mean those that appear without a nominalizer, as shown in the following example (Daisy Elijah, speaker):

- (48) waʔkneskwahni:nú: é:lhal
 waʔ- k- neskw- a- hninu- :’ elhal
 FACT- 1.SG.NOM- animal- JOIN- buy- PUNC dog
 ‘I bought a dog.’

If we assume that, like deverbal nouns, nominal roots also include a nominal *n* head, except that with so-called nominal roots *n* is phonologically null, then the analysis runs into a problem.¹¹⁶ With a null head intervening between V^0 and N^0 , there is no need to move N^0 , since Antisymmetry is satisfied.

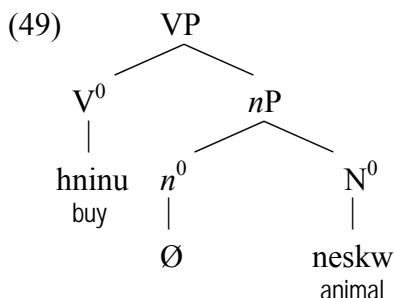

I propose that transitive and unaccusatives verbs in Oneida are subcategorized to take a complement bearing a nominal feature. If the complement is a deverbal noun, then the *n* element is required as in (44). Incorporation of a bare verbal root as shown in example (50), would violate the subcategorization frame of the higher verb.

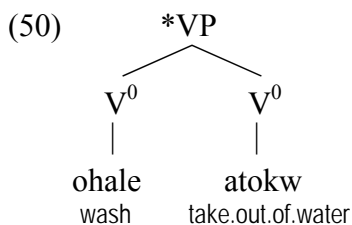

¹¹⁶ Note that Baker assumes that over nominals such as *elhal* (‘dog’) in (48) are merged directly into an adjoined position high in the tree. I postpone the treatment of noun incorporation with full DP doubles until section 3.5.2.

However, if the verb takes a nominal root as its complement, the requirement for a nominal feature is met and no nominalizer, overt or null, is required, as shown in (48).¹¹⁷

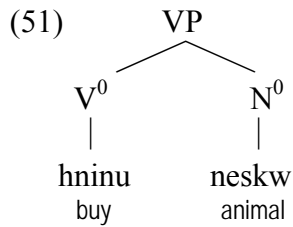

The structure in (51) violates the LCA, and as in other cases, the symmetry is eliminated by raising the noun to the specifier of the VP:

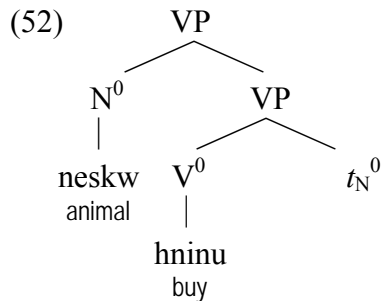

Up to this point we have only discussed the structure within the VP with respect to noun incorporation. We now move farther up the tree, starting with ApplP, if present, and then moving on to AspP. Recall from section 3.1 that applicative and aspectual morphology appear to the right of the verbal head. This indicates that the VP, including an incorporated nominal if there is one, must raise to the left of these two functional heads, leapfrogging (or snowballing, in Aboh's (2004a) terms) into the highest specifier position each time. Also, tense and agreement morphology appear to the left of the verbal head and incorporated noun, suggesting that the complex must raise only as far as the specifier position in AspP. This is expected, since v^0 is phonologically null. It thus allows

¹¹⁷ Thus, I do not adopt Marantz' (1997; 2001) view that lexical roots are category neutral. See also Caramazza and Shapiro (2004), Davis and Matthewson (1999), Pesetsky and Torrego (2004) and Don (2004) for similar approaches.

Compl-to-spec roll-up to stop once the verbal complex has raised as far as SpecAspP.

The resulting structure for the sentence in (48), repeated here, is given in (54).

- (53) waʔkneskwahni:nú: é:lhal
 waʔ- k- neskw- a- hninu- :’ elhal
 FACT- 1.SG.NOM- animal- JOIN- buy- PUNC dog
 ‘I bought a dog.’

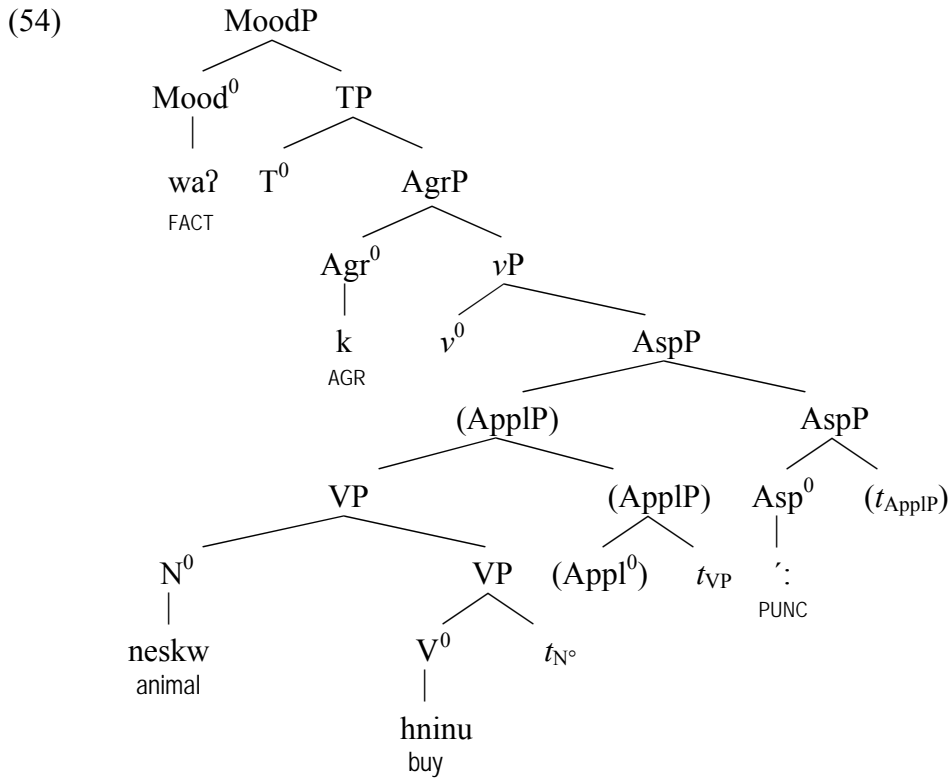

Note that there is no asymmetric c-command relation between N^0 , *neskw*, and v^0 , since the same set of maximal projections dominates both heads (namely, MoodP, TP, AgrP and vP – N^0 is not dominated by VP or AspP, since there is at least one segment of each of these projections that does not dominate N^0). This does not matter, however, since v^0 has no phonological content. Agr⁰ does asymmetrically c-command N^0 in (54) however, so the LCA is satisfied.

The next example shows the complete derivation for the incorporation of a deverbal root, using the sentence in (42), repeated below.

- (55) waʔutokwaʔtslóhaleʔ [M&D2002]
 waʔ u atokw a ʔtsl ohale ʔ
 PST 3.SG.F.NOM take.out.of.water JOIN NZLR wash PERF
 ‘She washed the spoon.’

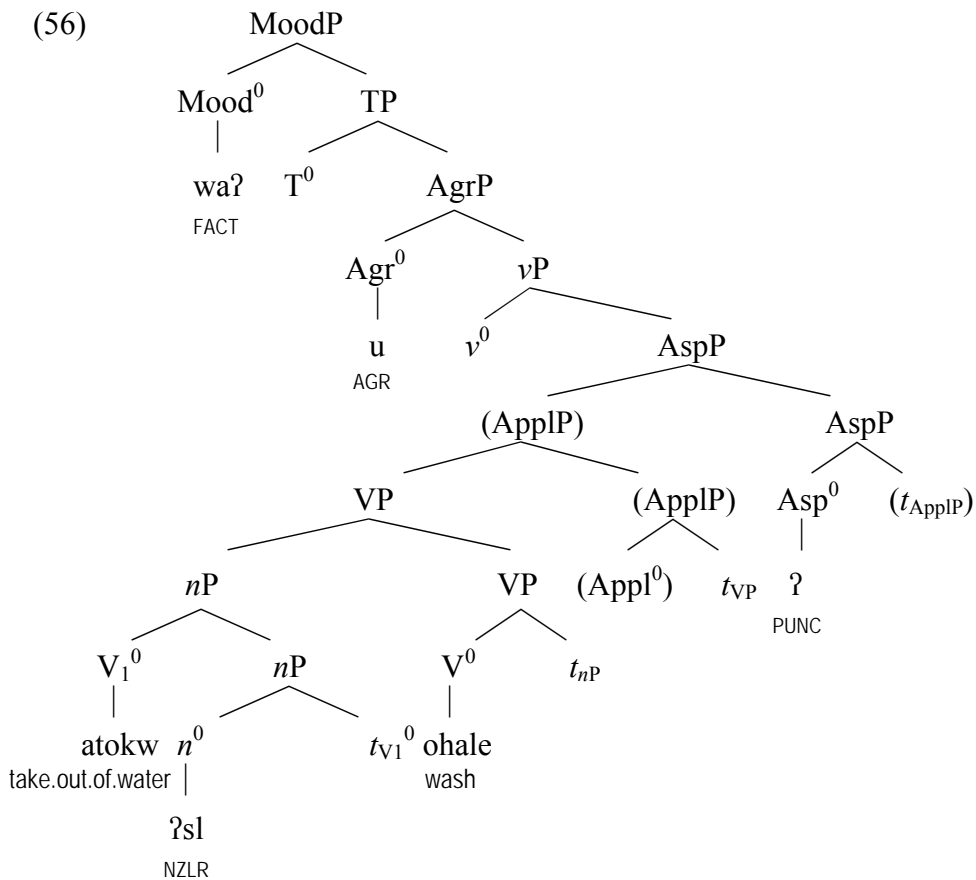

As above there is no asymmetric c-command relation between V_1^0 , *atokw*, and v^0 , since the same set of maximal projections dominates both heads (namely, MoodP, TP, AgrP and $vP - V_1^0$ is not dominated by nP, VP or AspP, since there is at least one segment of each of these projections that does not dominate V_1^0). This does not matter, however, since v^0 has no phonological content. Crucially, however, Agr⁰ does asymmetrically c-command V_1^0 in (56), so the LCA will be satisfied.

Finally, we take up noun incorporation in low applicatives, which was mentioned at the beginning of the chapter. Consider again example (5), repeated here as (57).

- (57) wahiʔslehtahni:nú: John [Daisy Elijah, speaker]
 wa- li- ʔslhet- a- hninu- ‘: John
 FACT- 1.SG.NOM3.SG.M.ACC- car- EPEN- buy- PUNC John
 ‘I bought John’s car.’ OR ‘I bought a car from John.’

Assuming, following Pyllkkänen (2002), that the low applicative phrase is below VP, we get the following partial structure for this sentence.

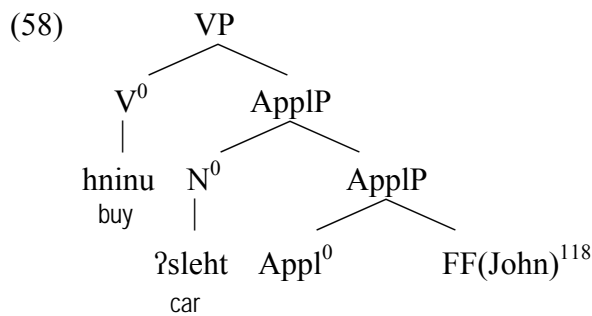

This configuration does not satisfy the LCA since the verb, *hninu* (‘buy’), and the noun, *ʔsleht* (‘car’), c-command each other. As above, Compl-to-spec roll-up is triggered and ApplP raises to SpecVP. The configuration of arguments in the ApplP demands some explanation. Pyllkkänen places the applied argument in SpecApplP under standard assumptions, namely, Spec-Head agreement. However, the Spec-Head relation has recently been called into question (Chomsky, 2005b). Hallman (2004) proposes that selection and feature checking must take place in a symmetric c-command relation, rather than in a Spec-Head relation. Under this view, the structure in (58) can be understood as follows. The applicative head, Appl⁰, selects the applied argument (which later raises to

¹¹⁸ Recall that I assume that full DP arguments raise to a position in the left periphery, thus we do not need to worry about its base position.

the left periphery¹¹⁹) in a symmetric c-command relation, that is as a complement to Appl⁰. The verb selects the theme argument as a direct object. Note that even though it is the verb that selects the direct object, the direct object is in SpecApplP. This is not a problem since the verb and the direct object c-command each other. Thus, the theme and verb are in a symmetric c-command relation in (58), as required. Thus, the very structure that is required for selection in turn triggers displacement.

In this section, I have argued that noun incorporation is driven by the grammar's need to satisfy the LCA by eliminating instances of symmetric c-command. In the simplest case, a verb selects a bare noun, entering into a symmetric c-command relation with it. Symmetry is eliminated by Compl-to-spec movement of the noun to SpecVP. In the case of incorporated deverbal nouns, the nominalizer selects a bare noun. Compl-to-spec roll-up is triggered as just illustrated, causing the noun to raise to Spec*n*P. The verb then merges with the structure thus formed, giving rise to another instance of symmetric c-command. Again, symmetry is eliminated by the *n*P raising to SpecVP.

In the next section, we address some of the other properties of Iroquoian DPs.

3.4. Iroquoian DPs

Ordinary nominals in Iroquoian consist of a nominal root, a nominal prefix and a noun-forming suffix, as shown in (59)a. (Abbott, 2000; Chafe, 1960a, 1960b, 1960c, 1960d; Froman *et al.*, 2002; Lounsbury, 1949, 1953; Williams, 1976; Woodbury, 2003). When the nominal is incorporated, as in (59)b, neither the prefix nor the suffix appears.

¹¹⁹ See the discussion on p. 6.

(59) *nominal prefix + noun root + noun-forming suffix (NFS)*

- a. ohnaná:taʔ [M&D2002]
 o- hnanaʔt- aʔ
 NPREF- potato- NFS
 “potato”
- b. waʔkathnanaʔtu:tʌ:
 waʔ- k- at- hnanaʔt- ut- ʌ:
 PST- 1.SG.NOM- SREFL- potato- bake- PERF
 “I baked potatoes.”

The proposed structure for a full DP, with all elements in their merge position, is shown in (60).¹²⁰ I have arbitrarily placed the noun prefix under D^0 , although it is morphologically related to the set of verbal agreement markers.¹²¹

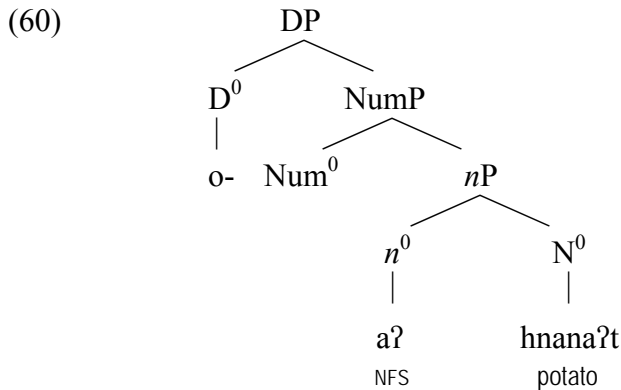

As has been argued throughout, when n^0 is phonologically realized, the nominal root N^0 must raise to the specifier of nP to eliminate the instance of symmetry. Once N^0 has moved, the three overt terminal elements in (60), D^0 , N^0 , and n^0 are totally ordered by the LCA, once this raising takes place. The resulting structure for the nominal in (60) is therefore as in (61).

¹²⁰ See (Ritter, 1992) for cross-linguistic evidence for the existence of a NumP. A candidate for Num⁰ in Oneida is a morpheme referred to as a “collectivizer morphemes” in the traditional Iroquoian literature. This morpheme is optional and is used for large groups.

¹²¹ Kim (1997) suggests that Korean DPs contain AgrPs. I have not investigated whether her proposal can be carried over to the Oneida facts in a meaningful way.

(61)

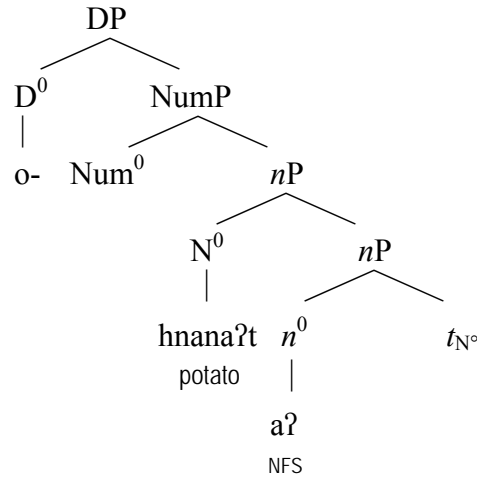

The structure of full DPs in Oneida, then, results from the fact that symmetric c-command between the noun and the light noun must be eliminated.

The next section deals with various properties of Iroquoian noun incorporation and will show that these properties are compatible with the theory of linearization developed in Chapter 2.

3.5. Properties of Iroquoian Noun Incorporation

This section discusses some of the other properties of Iroquoian noun incorporation. Many of these properties are discussed at length elsewhere in the literature (Baker, 1996; Mithun, 1984; Rosen, 1989). These include the restriction of noun incorporation in ditransitives to themes (and the inability of goals to undergo noun incorporation), modifier stranding, and the doubling of the incorporated nominal. One other property that has not been discussed in the literature before is noun incorporation in conjoined structures. This section presents new data from Oneida on this last topic.

3.5.1. Noun Incorporation in Ditransitives

We have already seen an example of noun incorporation in a ditransitive at the end of the previous section, in which noun incorporation of the theme argument took place. In virtually all languages that permit noun incorporation, only the theme internal argument can undergo noun incorporation; the goal/source argument cannot.¹²² The following examples from Mohawk (Baker, 1996: 207) illustrate this fact.

(62) Noun Incorporation in Mohawk Ditransitives

- a. t- a'- khey- athvni- tsher- u- ' ne owira'a
 CIS- FACT- ISS/FSO-ball- NZLR- give- PUNC NE baby
 'I gave the ball to the baby.'
- b. #t- a'- ke- wir- u- ' ne athvno
 CIS- FACT- ISS- baby- give- PUNC NE ball
 'I gave the baby to the ball.' (NOT 'I gave the ball to the baby.')

In (62), the theme is incorporated in the first sentence. In the second sentence, *wir* ('baby') is incorporated, and the construction can be understood only with *wir* as the theme, not the goal. As mentioned briefly above, the theme argument is the direct object of the verb, as demonstrated by the fact that it appears with accusative Case in the vast majority of nominative-accusative languages. The goal/source argument, on the other hand, is typically marked with some other oblique Case such as dative. Thus, the goal/source argument is the applied argument, introduced by ApplP. Also, as explained above, Hallman (2004) argues that feature checking and selection take place under mutual c-command, suggesting the following structure for low applicatives.

¹²² Putative noun incorporation in English obeys this constraint, too. Thus, *gift-giving* is an acceptable structure in English, while **neighbour-giving*, meaning 'giving to one's neighbours' is not. Likewise, a child-stealer is someone who steals children – not someone who steals *from* children.

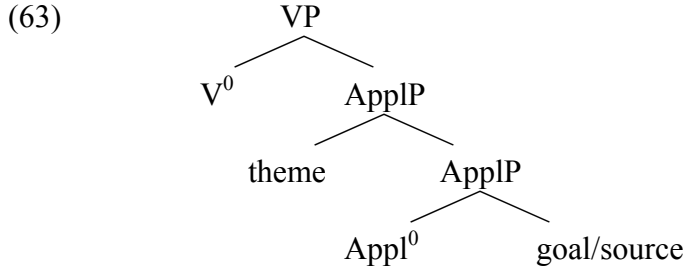

In this configuration, the verb and the theme c-command each other, and the applicative head and the goal/source argument also c-command each other. Thus, only the theme enters into a relation of symmetric c-command with the verbal head. This explains the virtual cross-linguistic absence of goal/source noun incorporation. This argument is never in a symmetric c-command configuration with the verb to trigger Compl-to-spec roll-up.¹²³

An example of the incorporation of a theme was shown above and is repeated here, with the accompanying VP structure.

- (64) wahiʔslehtahni:nú: John [Daisy Elijah, speaker]
 wa- li- ʔslhet- a- hninu- ‘: John
 FACT- 1.SG.NOM3.SG.M.ACC- car- EPEN- buy- PUNC John
 ‘I bought John’s car.’ OR ‘I bought a car from John.’

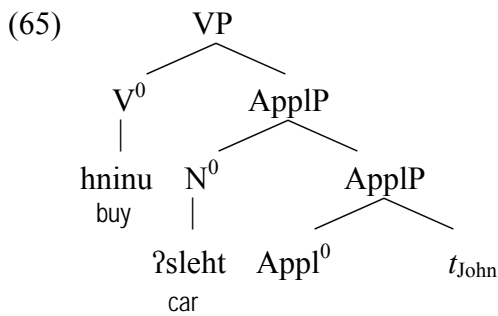

In (65), the verb and the noun are in a symmetric c-command configuration, triggering Compl-to-spec raising of the ApplP to SpecVP. I have represented the source argument,

¹²³ This account suggests the possibility of goal/theme incorporation in languages that have an overtly realized Appl⁰ head. In such a case, Appl⁰ and the goal/theme c-command each other, triggering the nominal to raise to SpecApplP. When the verb merges with the ApplP complex, Compl-to-spec roll-up will once again be triggered. Whether such a language exists or not I leave for future research.

John, as a trace as I assume that overt DPs raise to a topic or focus position in the overt syntax.¹²⁴ The VP complex thus formed is merged with an aspectual morpheme, which triggers raising of the VP to SpecAspP. The final derivation is shown below (DP, *John*, not shown).

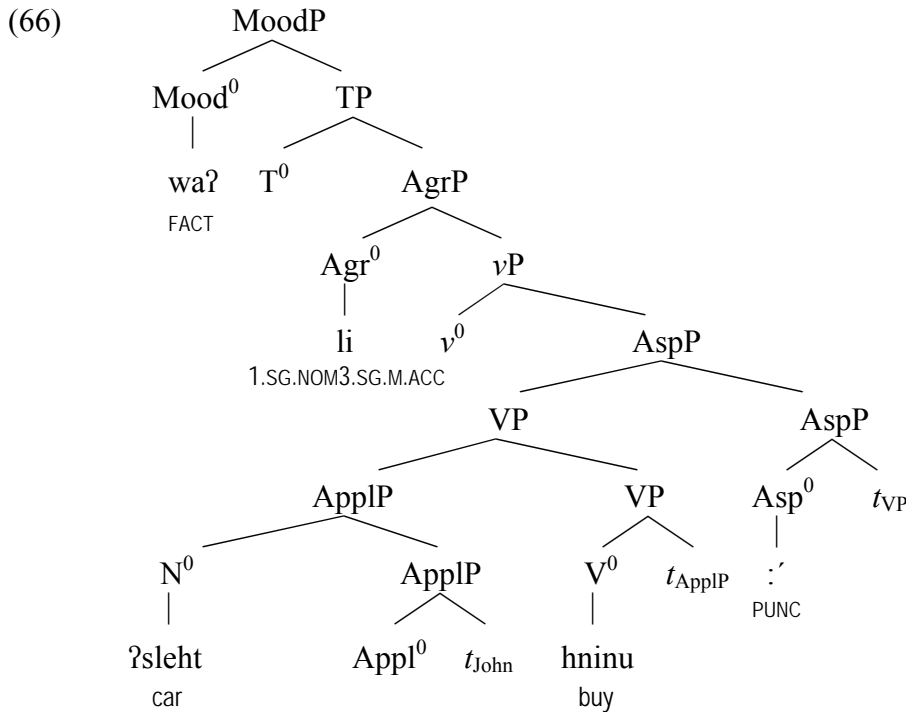

This section has shown that one of the core properties of noun incorporation, its inability to apply to goal/source arguments, can be explained with the Dynamic Antisymmetry approach proposed here. The next section discusses noun incorporation with overt DPs.

3.5.2. Noun Incorporation and Overt DPs

One of the original challenges to a syntactic approach to noun incorporation is the fact that incorporated nouns can be doubled by full DPs. Baker (1996) proposes that full DPs

¹²⁴ It is possible that Case in Oneida is checked *in situ* and thus does not need to move to a Case checking position, suggesting that Oneida lacks A-movement altogether. See Ritter and Rosen (2005) for a proposal along these lines for Algonquian.

in Mohawk (and in Northern Iroquoian in general) are adjoined outside the clause, in the spirit of Jelinek's (1984) Pronominal Argument Hypothesis. I suggest here that DPs can be merged in argument position, while still maintaining a syntactic account of noun incorporation.¹²⁵ I propose that the incorporated element in a doubled noun incorporation construction is actually a classifier, and occupies the specifier of a classifier phrase.¹²⁶ I argue that the classifier nominal is a specifier, rather than a head, because a full DP can be found in its place in certain environments. The following example, from Daisy Elijah, shows a conjoined DP, *pig and apple* where the classifier for pig (*-neskw-*) is incorporated, and the classifier for apple, *kahik*, is a full DP.

- (67) waʔ-k-neskw-a-hni:n-ú: kóskos oʔkhále swahiyo:wʌneʔ kahik
 FACT-1SG-animal-EPEN-buy-PUNC pig and apple fruit
 'I bought a pig and an apple.'

Let us consider doubled noun incorporation in a non-conjoined structure. Unlike classifiers in Chinese languages (Cheng and Sybesma, 1999; Li, 1999), the classifiers discussed here must appear fairly high in the extended nominal projection. This is because the classifier never appears lower than any D⁰ element, thus it never appears inside the DP (see next section for details on the internal structure of nominals). With this in mind, let us consider the derivation for the following sentence.

- (68) waʔ- k- neskw- a- hni:n- ú: kóskos[Daisy Elijah, speaker]
 FACT- 1.SG- animal- EPEN- buy- PUNC pig
 'I bought a pig.'

¹²⁵ See Russell and Reinholtz (1997) for a detailed approach in which arguments are merged inside the VP in Cree.

¹²⁶ Historically, classifiers developed from nouns (Wang, 1994). Thus, Oneida may be in the early stages of becoming a classifier language.

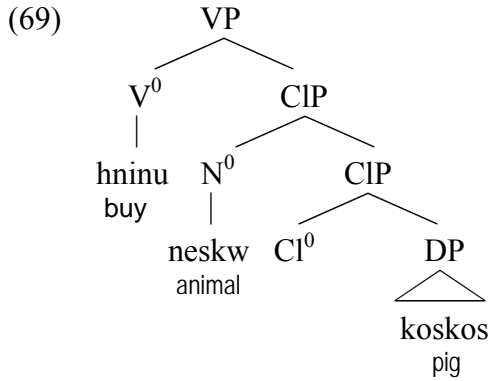

In (69), the classifier noun, *-neskw-* appears as a head in SpecCIP. When the verb merges with the CIP with the classifier in its specifier, the verb and the classifier are in a relation of symmetric c-command. Recall from chapter 2 that I proposed that symmetric c-command could be resolved by raising a lower element in the tree if such a move satisfied some property of the lower element or if moving the higher element would violate some morphological filter. This is schematized in (70). In this example, X^0 is a relation of symmetric c-command with Z^0 – exactly the same scenario as above with the verb and the classifier noun. In chapter 2, I argued that, in the general case, this point of symmetry is removed by raising YP to SpecXP. However, I argued that Z^0 could be raised if it satisfied some property of Z^0 or if raising YP would cause the derivation to crash.

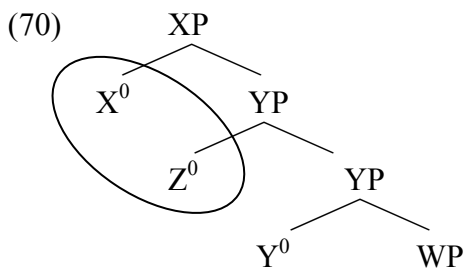

I suggest here that moving the entire CIP to SpecVP would violate some principle of grammar, thus raising of the classifier noun is preferred. For example, one could argue that the classifier noun requires a lexical host, since it is somehow phonologically

deficient. When the verb merges with CIP, the classifier noun is adjacent to the verb, so the verb can act as a phonological host. However, the verb and the noun are in a symmetric c-command relation. If CIP were to raise to SpecVP, it would break the lexical hosting relation between the verb and the classifier noun. One could argue that once the verb hosts the classifier noun, this relation must be maintained; thus, the only solution is to raise the classifier noun by itself to SpecVP. I leave the choice between these options to future research. The final structure is shown below.

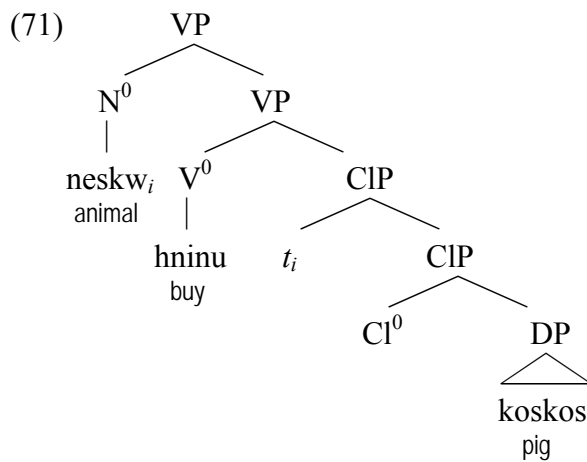

This section has shown that many of the core properties of noun incorporation including the fact that a theme argument, but not a goal argument, may be incorporated, and the possible doubling of the incorporated noun by a full DP, can be captured by the theory of Dynamic Antisymmetry proposed here.

3.6. Conclusion

In this chapter, I have argued for an analysis of noun incorporation and DPs in Oneida that is based on Dynamic Antisymmetry and Bare Phrase Structure. Specifically, I proposed that noun incorporation in Oneida has the effect of eliminating symmetric c-command between the verb and its internal argument. Incorporation of a deverbal noun

requires an overt nominalizer, or n^0 . When the nominalizer merges with the deverbal noun, the noun raises to *SpecnP* to satisfy the LCA, and when the *nP* complex merges with the verb, the *nP* raises to *SpecVP*, in the Compl-to-spec roll-up manner described. In both cases, Compl-to-spec movement of N^0 is eventually halted by the null v^0 .

DPs in Oneida were discussed briefly, and the internal order of the morphemes was accounted for by the proposal presented here – namely, Compl-to-spec movement of N^0 triggered by the need to satisfy the LCA. The nominalizer merges with the noun, creating a structure that violates the LCA due to symmetric c-command. This is resolved by raising the noun to *SpecnP*. The *nP* then merges with a phonologically null Num^0 . Although the noun and the Num^0 are in a symmetric c-command relation, no movement is required since the head of *NumP* is null. Now, when the overt D^0 merges with the *NumP*, no further movement needs to take place to satisfy the LCA. At the end of the chapter, I discussed some general properties of noun incorporation in Iroquoian, including the fact that the theme, but not the goal/source argument of a ditransitive can under incorporation, and noun incorporation doubled by an overt DP. Both of these properties were shown to fall out from the theory of phrase structure proposed here.

The next chapter discusses nominal compounding in English, German and Persian, and noun incorporation in Tamil. It will be shown that these languages have constructions similar to noun incorporation in Oneida, which can be accounted for by the framework proposed in chapter 2.

4. Noun Incorporation and its Kind in Other Languages

In this chapter, I propose an analysis of noun incorporation in English gerunds using the theory of phrase structure proposed in Chapter 2. This chapter is organized as follows. In section 4.1 I discuss the patterns of noun incorporation found in English gerunds. In section 4.2 I give an analysis of these structures using a Dynamic Antisymmetric formulation of Bare Phrase Structure. In section 4.3, I look at related phenomena in German and Persian. Specifically, I examine noun+verb compounding in German *beim* constructions and “long infinitives” in Persian. Finally, in section 4.4, I look at a construction in Tamil which has been argued to be noun incorporation. What is interesting about the Tamil data is that conjoined nouns can be incorporated.

4.1. Patterns of English Gerunds

English is not traditionally thought of as having noun incorporation. Examples such as *babysit* and *grocery shop* are rare, and are usually backformations from nominalized forms (*cf.* ‘babysitter’ and ‘grocery shopping’). Noun incorporation into gerunds, however, does seem to be highly productive in English as the following examples illustrate.

- (2) I went *elk-hunting* the other day.
- (3) Peter really enjoys *teacup-decorating*.
- (4) Alice wants to try *ladder-making* to keep her wood-working skills sharp.

We see from (5)a and (5)b that only a bare nominal root may appear in the incorporated forms. Conversely, bare singular count nouns cannot appear unincorporated, as shown in

(5)c and (5)d. Example (6) shows that the incorporated forms must indeed be bare nominal roots, and cannot take any inflectional elements at all.

(5) *Noun Incorporation in English Gerunds*

- a. Will really enjoys teacup-decorating.
- b. *Will really enjoys teacups-decorating.
- c. Will really enjoys decorating teacups.
- d. *Will really enjoys decorating teacup.

(6) *Impossible Gerunds in English*

- a. *Will enjoys watches collecting
- b. *Will enjoys the watch(es) collecting.
- c. *Will enjoys some watches collecting.
- d. *Will enjoys a watch collecting.

Note that what appears to be a bare noun can appear as the unincorporated complement to a gerund if it is a mass noun, or receives a mass interpretation:

(7) *Mass Nouns*

- a. Will enjoys drinking wine.
- b. Will hates washing glass.

Example (7)b is grammatical if *glass* is a mass noun, but not if it refers to an individual glass or to individual glasses for drinking. In order to get the count reading, in which *glass* refers to drinking glasses, we must either add plural morphology as in (8)a, or use an incorporated structure as in (8)b. Note that (8)b is now ambiguous between a count reading and a mass reading.¹²⁷

¹²⁷ Not discussed here are the institutionalized readings available for incorporated gerunds. A typical example is *wine-tasting*, which does not refer to any generic act of tasting wine, but to a specific, conventional activity. The stress facts here are important. In the institutionalized event, there is only one lexical stress on *wine-tasting*:

i. Christine enjoys wine-tasting.

On the generic reading, both *wine* and *tasting* bear lexical stress:

ii. Christine enjoys wine-tasting.

Furthermore, on the institutionalized reading, the phrase can be pluralized (*wine-tastings*). This is not possible on the generic reading. See also footnote 128. Some speakers have difficulty in getting the generic

- (8) a. Will hates washing glasses.
b. Will hates glass-washing.

Before proceeding with the analysis of these structures, it should be noted that noun incorporation into gerunds is often thought to be a lexical rather than a syntactic process. Di Sciullo and Williams (1987) argue that units inside a word are not referential. That is, words are “referential islands” in their terms. This accounts for the contrast in the following two sentences.

- (9) John is a Nixon-admirer in every sense except that he does not actually admire Nixon.
(10) *John admires Nixon in every sense except that he does not actually admire Nixon.

In (9), *Nixon* is inside the lexically formed word *Nixon-admirer*, and is thus not referential. This accounts for the relative acceptability of this sentence. By contrast, in (10), *Nixon* is an independent syntactic entity, and is thus referential, giving rise to the contradiction. Consider now the following two sentences:

- (11) John is an apple-picker, but never actually picks any apples.
(12) *John enjoys apple-picking, but he doesn't actually enjoy picking apples.

Most native speakers generally agree that (11) is much better than (12), suggesting that apple is referential in (12), thus not part of a larger word.¹²⁸ I take this as evidence that noun incorporation in gerunds in English is a syntactic rather than lexical process.

reading with *wine tasting* because of salience of the institutionalized reading. The generic reading is more readily available on novel incorporation structures such as *grapefruit-peeling* or *sock-darning*.

¹²⁸ Note that under the institutionalized reading, the sentence in (12) becomes much better. What this means is that John enjoys all the activities go along with apple-picking, such as the socializing, tree-climbing, etc. but he doesn't enjoy the physical act of picking apples. I assume that the institutionalized readings are lexically formed; whereas the generalized readings are syntactically formed. See also footnote 127.

In this section, we have seen that only nouns that are morphologically bare can, and in fact must, undergo incorporation into a gerund in English, where they are unspecified for the count/mass distinction and are thus ambiguous between the two readings.¹²⁹ Count nouns with any additional morphology and nouns that are obligatorily specified as mass nouns cannot undergo incorporation. The next section proposes a preliminary analysis that accounts for these facts using the theory of Dynamic Antisymmetric Bare Phrase Structure developed in Chapter 2. After the preliminary analysis, we will consider further data and sharpen our analysis.

4.2. Analysis¹³⁰

I propose that in the incorporated forms discussed here, the gerund merges with a bare noun – that is an N^0 , a noun without any functional material above it.¹³¹ The data from example (6) above shows that any DP morphology is ruled out in these constructions. Recall also that the incorporated noun is unmarked for number and the count/mass distinction. Following Ghomeshi (2003), I assume that number and the count/mass distinction is encoded on Num^0 as shown here.

¹²⁹ Pragmatics or semantics may force one interpretation over the other, but crucially, this is not a property of the incorporated noun. For example, in the phrase *chicken-sorting* a count interpretation is forced because the act of sorting requires discrete entities. Likewise, in the phrase, *garlic-mashing*, a mass interpretation is strongly preferred because of what is involved in the act of mashing.

¹³⁰ I do not consider here the peripheral but interesting topic of the structure of the left periphery of the various kinds of gerunds in English. See Moulton (2004) and Pires (2002) for discussion.

¹³¹ This is a potential point of confusion. The term “bare noun” is often used to refer to a noun without any overt nominal morphology attached to it. I am using the term here to refer to an N^0 without any extended nominal functional projections, either overt or covert. Thus, when I say a verb merges with a bare noun, I intend the following structure:

(i) $[_{VP} V^0 N^0]$

See footnote 2.

(13) *Number Heads*

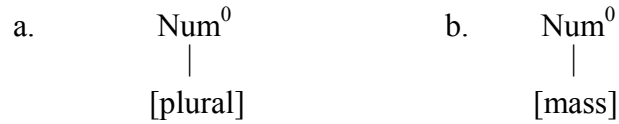

Since the incorporated noun is always unspecified for both number and the count/mass distinction, we can assume that it does not include Num⁰. This conclusion suggests that the gerund takes a bare noun object in the incorporation structures as in (14)a), whereas the non-incorporating structures have a full DP object, as in (14)b).¹³² The structures shown in (14) have all elements in their Merge positions.

(14) *English Gerund Constructions*

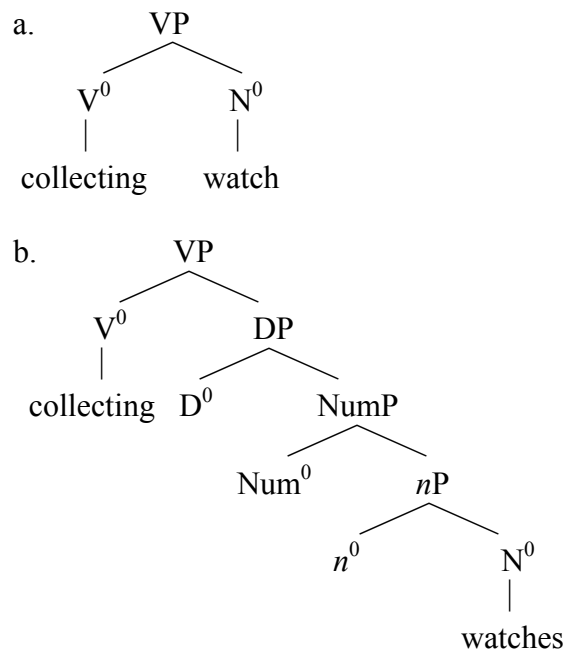

The structure in (14)a) violates the LCA as the two lexical items are in a symmetric c-command relation. This violation is resolved by raising the noun to SpecVP, as shown in (15). Since there is no such violation in the second example, no movement is required.

¹³² I have included a *nP* in the full DP structure, tacitly assuming that all lexical categories require a light counterpart when they are not bare (Marantz, 2001; Ogawa, 2001).

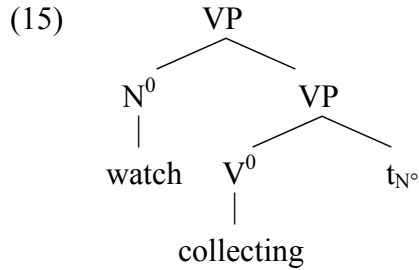

To see why (8)b, but not (7)b, is ambiguous, consider the structures in (16).

(16) *Ambiguity in noun incorporation in English*

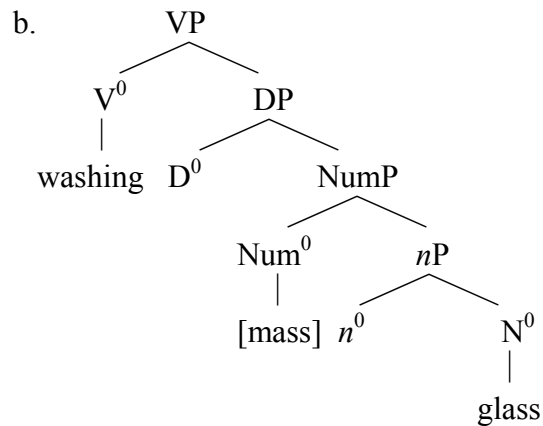
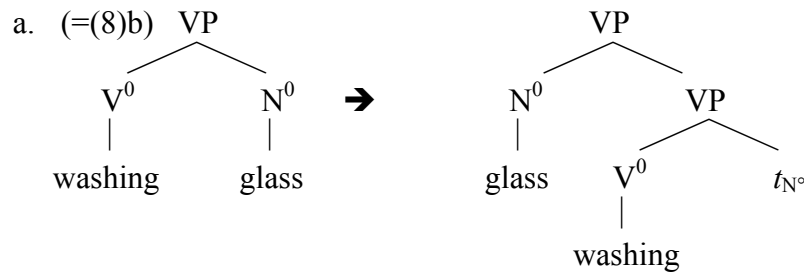

As a bare noun, *glass* in (16)a does not have a number projection, and is thus unspecified for number and the count/mass distinction. Although the noun *glass* in (16)b looks like a bare noun, I argue that it actually possesses a full DP structure as shown. Crucially, it must possess a Num⁰ valued as [mass], since it must receive a mass interpretation here. Thus, the noun *glass* in (16)b is not “bare” in the sense assumed here. That is, it is not a bare N⁰ with no extended nominal projections.

This observation is in accord with the discussion on phonologically null heads in chapter 2, section 2.4. There it was noted that phonologically null heads must have semantic content. Thus, the pair of constructions, *glass-washing* and *washing glass* must have different semantics. I argued that in *glass-washing*, the noun is a bare N⁰ and lacks a Num⁰ projection. As such, it is unspecified for a count/mass distinction. In *washing glass*, on the other hand, *glass* can only have a mass interpretation.

This section has discussed noun + gerund compounds in English gerunds as an instance of noun incorporation. The word order facts were accounted for using Dynamic Antisymmetry approach to Bare Phrase Structure as proposed in Chapter 2. As before, the order N + V arises by movement of the noun to SpecVP to satisfy the LCA. Since the order V + DP does not violate the LCA, no movement is required. Furthermore, the mass/count ambiguity of N + V compounds with nouns like *glass* is accounted for by the fact that N + V structures can only arise with bare nouns, which lack a number projection. Thus, no number or count/mass distinction can be specified on N + V structures.

4.3. Incorporation into Gerunds and Progressives in Other Languages

In this section, I examine phenomena similar to the English constructions just discussed, but with small differences in each case. The data will be shown to support the theory proposed here. We begin with progressives in German. The German data are interesting because both singular and plural nouns can be incorporated into progressive verb forms.

4.3.1. German Progressives

Examples such as those in (17) have been the subject of much study (Clahsen *et al.*, 1995). The compounds *Äpfel-essen*, *Mäntel-kaufen*, and *Wildschweine-jagen* (literally,

‘apples-eating’, ‘coats-buying’, and ‘boars-hunting’) are problematic for theories of word-formation such as Lexical Phonology (Kiparsky, 1982), because inflectional morphology (the plural marking) appears inside the compound, and compounding is thought to be a derivational process.¹³³ The account of these structures presented below, however, follows naturally from the proposal here and the semantic effects of the presence or absence of plural marking in these structures.

(17) *German Progressives*

- a. Ich bin beim Äpfel- essen.
 I am at.the apple.PL- eat.INF
 ‘I’m eating apples.’ / ‘I’m busy apple-eating.’
- b. Er ist beim Mäntel- kaufen.
 he is at.the coat.PL- buy.INF
 ‘He’s buying coats.’ / ‘He’s busy buying coats.’
- c. Der Mann ist beim Wildschweine- jagen.
 the man is at.the boar.PL- hunt.INF
 ‘The man is boar-hunting.’

The problem here is the plural marking on the first element of the compound. The received wisdom on this topic is that inflectional morphology cannot appear inside a compound, whether regular or irregular, as the following English examples demonstrate.

- (18) bee-keeper, *bees-keeper; toothbrush, *teethbrush

¹³³ Note that the putatively regular plural marker /-s/, does not occur inside compounds.

- i. * Ich bin beim Auto-s-kaufen
 I be.1SG at.the car-PL-buy.INF
 (‘I’m buying cars.’)

Because of this, it has been argued that the irregular plural morphology (as found in the data in this section) is derivational rather than inflectional, thus alleviating the problem for Lexical Phonology (Clahsen *et al.*, 1995). I address this point at the end of this section.

German has SOV word order in embedded contexts, so we must show that the examples in (17) are not simply a case of standard SOV order, but rather are some type of incorporation structure. Consider the following contrast.

- (19) ...dass ich die Äpfel (in der Küche) essen möchte.
 ...that I the apples (in the kitchen) eat.INF would.like
 ‘...that I would like to eat the apples (in the kitchen).’ [PP modifies VP]
- (20) Ich bin beim Äpfel (*in der Küche) essen.
 I am at.the apples (in the kitchen) eat.INF
 ‘I’m busy eating apples (in the kitchen).’

In a standard SOV construction as in (19), adjuncts and adverbial may intervene between the direct object and the verb. In the putative cases of noun incorporation such as in (20), no intervening material can appear between the verb and the incorporated object, suggesting a much closer syntactic link in the noun incorporation structures than in the standard sentences.

Compounds where the first element is singular are possible, of course, but there is a change in meaning. Consider the following contrast.

(21) *Singular and Plural Compounds in German*

- a. Ich bin beim Äpfel- essen.
 I am at.the apple.PL- eat.INF
 ‘I’m eating apples.’ / ‘I’m busy apple-eating.’
- b. Ich bin beim Apfel- essen.¹³⁴
 I am at.the apple- eat.INF
 ‘I’m busy eating an apple/some apples.’
- c. Er ist beim Mäntel- kaufen.
 he is at.the coat.PL- buy.INF
 ‘He’s buying coats.’ / ‘He’s busy coat-buying.’

¹³⁴ My consultant reported that this sentence sounds strange, since this construction is used for extended activities where the participant is off busy doing something. Since eating an apple is generally rather quick, this sentence is odd. The consultant said that it would make sense for this sentence to be uttered by a worm in a child’s cartoon, for example.

- d. Er ist beim Mantel- kaufen.
 he is at.the coat- buy.INF
 ‘He’s buying a coat/some coats.’
- e. Der Mann ist beim Wildschweine- jagen.
 the man is at.the boar.PL- hunt.INF
 ‘The man is boar-hunting.’
- f. Der Mann ist beim Wildschwein- jagen.
 the man is at.the boar- hunt.INF
 ‘The man is hunting a boar/some boars.’

When the first element in the compound is singular, there is no specification for number. In (21)b for example, the speaker could be eating a single apple or many apples. When the first element in the compound is plural, however, there is an implication that there must be more than one of the objects specified.¹³⁵

These facts suggest the following merged structures for these types of constructions, where [+front] refers to the phonological representation of the plural formation in the German nouns in question.

(22) *Merged Structures for German Compounds*

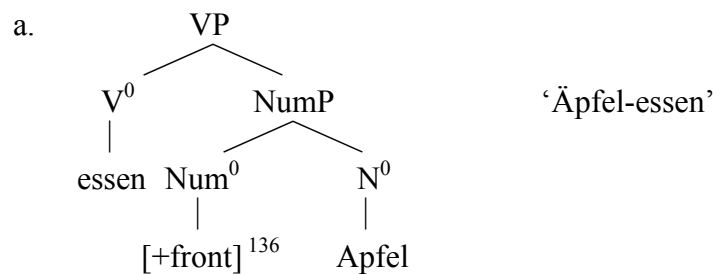

¹³⁵ There are a few exceptions to this generalization. The forms *Bären-schiessen* (‘bear-shooting’) and *Hirsche-jagen* (‘deer-hunting’) can appear in the plural only and are underspecified for number. I suggest that these forms are lexically stored as a single lexical item in contrast to the forms under investigation here, where I suggest a syntactic analysis is in order.

¹³⁶ I represent the plural morpheme as a floating [+front] feature because of the umlaut on the first vowel.

- i. Apfel → Äpfel [apfəl] → [ɛpfəl]
- ii. Mantel → Mäntel [mantəl] → [mentəl]

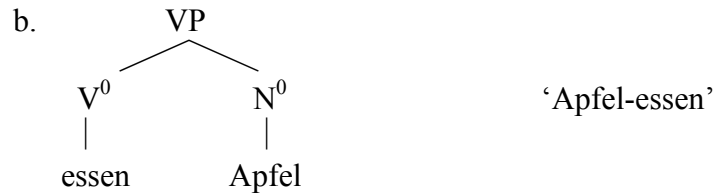

Since the plural marking on the first element of these compounds is semantically interpreted, there must be a Num⁰ above N⁰ in the compound. In contrast, when the first element of the compound lacks plural marking, there is no specification for number at all. These structures, therefore, lack the number projection altogether. Consequently, both of the structures in (22) violate the LCA. Compl-to-spec movement therefore takes place, giving the structures in (23).

(23) *Spelled-Out Structures for German Compounds*

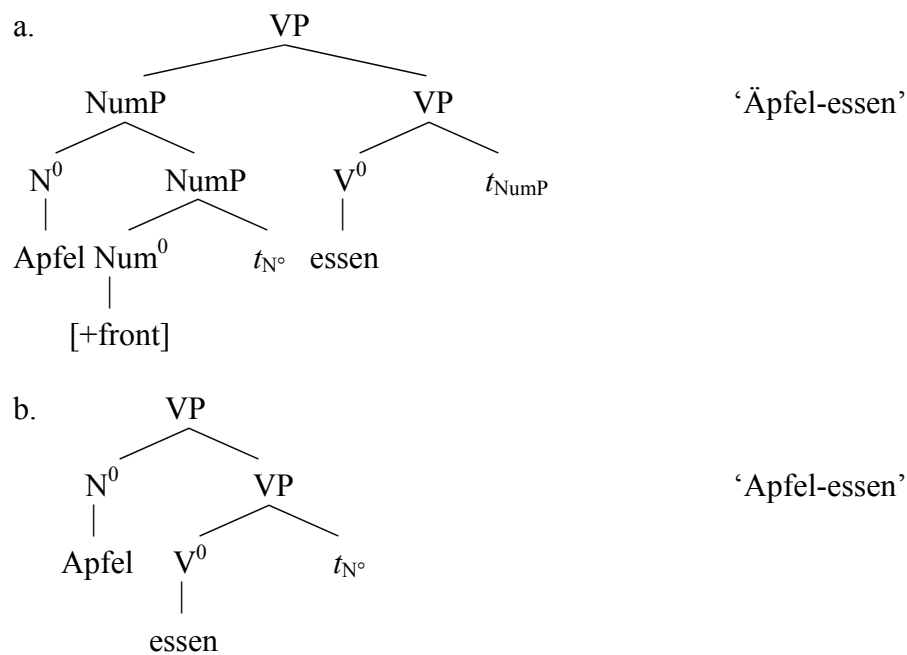

Before concluding this section, a word is in order concerning the availability of incorporating plural nouns in German, but not in English. Recall from footnote 133 that the regularized German plural, which uses the morpheme /-s/, is unavailable in these constructions.

- (24) * Ich bin beim Auto-s kaufen.
 I am at car-PL buy.INF
 ('I'm busy buying cars.')

I would like to adopt the suggestion by Clahsen *et al.* (1995), where it is claimed that the plural morphology on the noun *Autos* in (24) is inflectional, whereas the plural morphology on the noun capable of being incorporated into gerunds as in (21) are derivational.¹³⁷ I suggest, pending further research, that the distinction between derivational number and inflectional number can be captured as follows. Derivational number appears on a low NumP, between *nP* and NP, while inflectional number appears on a higher NumP, above *nP*. Whereas English lacks derivational number, German irregular plurals are derivational. Thus, the structures for the examples with incorporation are the same as argued for above. These assumptions are, of course, stipulatory. Alternatively, one could simply assume that irregular plurals in German are lexically formed, while regular plurals are formed in the syntax. Thus, a form such as *Äpfel*, ('apples') is inserted directly under N^0 , and the lower NumP in (25) not required. In reading the tree in (25), then the reader could consider the lower NumP a representation of either a lexically formed irregular plural, or a syntactically formed irregular plural with derivational number. Incorporation in German *beim*-constructions (and in English gerunds) is thus restricted to NP or the lower NumP, if present.

¹³⁷ The distinction for German isn't as clear cut as one would hope, however. Kahnemuyipour (2000) and Wiltschko (2004) give several criteria that show that number in Persian is derivational. The only properties of plurals in German that suggest that they are derivational are the fact that they are irregular, and the fact that they can appear inside other derivational morphology as discussed here.

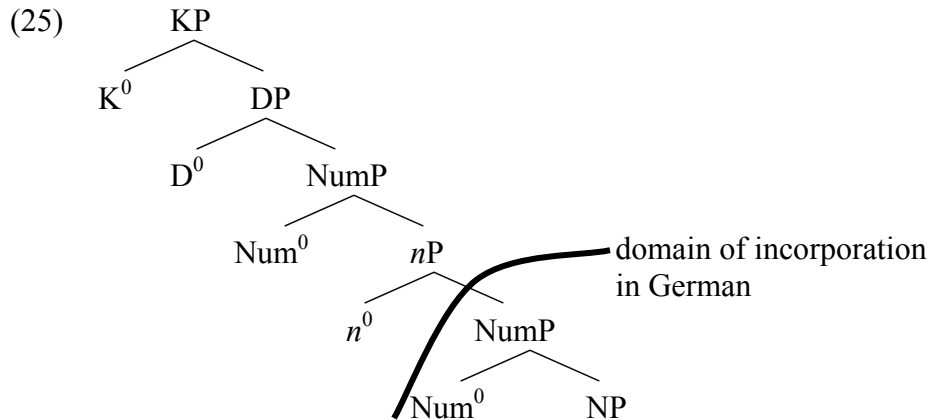

This effectively restricts incorporation in German to irregular (i.e., derivational) plural, and completely bars it in English, since there is no derivational number.¹³⁸

To recapitulate, German allows both singular and plural nouns to appear in incorporation structures with progressive verb forms. The structures with singular nouns are unspecified for number, whereas the structures with plural nouns must have a plural reading. I take this as evidence for the presence of a Num head in the structure with the plural variant but not in the structure with the singular variant. As a result, the heads in question in both the unmarked and the plural variants enter into a mutual c-command relation triggering spec-to-comp roll-up as illustrated in (23).

4.3.2. Persian “Long Infinitive” Constructions

In this section, I examine the so-called “long infinitive”¹³⁹ verb form in Persian and show that the Persian facts are easily explained by the theory of phrase structure developed

¹³⁸ These assumptions require a large-scale cross-linguistic investigation of derivational versus inflectional number. I leave this investigation to future research. Note that in English, some irregular plurals are found in incorporated forms such as *people-watching*. Such forms are inevitably lexical as described above. A google search, however, uncovers some other forms. *Mice-hunting* registers 924 hits on google.com, *geese-hunting* scores 15, 900 and *feet-washing*, 31,700.

¹³⁹ For a discussion of this verb form in the wider context of the syntax of Persian, see Ghomeshi (2001) and Kahnemuyipour (2001).

here. Following (Ghomeshi, 1997b, 2003), I assume the structure in (26) for nominals in Persian.

(26) [KP [QP [DP [CardP [NP]]]]]

Ghomeshi argues that numerals appear in a Card(inality) Phrase in both English and in Persian, and that Persian does not have a NumP. I adopt her analysis here, although nothing crucial hinges on this decision. The KP hosts the definite object marker /râ/. Since this marker does not appear in the constructions under consideration here, it will not appear in the structures illustrated below.

Persian uses the long infinitive in a variety of constructions. The data discussed here are translated as gerunds in English, but are argued to be nominal constructions in Kahnemuyipour (2001).¹⁴⁰

(27) *Long Infinitives with Post-Verbal Complements*

- | | | | | | | |
|----|----------------------------------|------|------------|--------------------|-------------|---------------|
| a. | sima | æz | xundæn-e | ketab | xoš-eš | mi-yad |
| | Sima | from | reading-EZ | book | good-3SG.CL | CONT-come.3SG |
| | ‘Sima likes reading books.’ | | | | | |
| | | | | | | |
| b. | sima | æz | xundæn-e | in ketab | xoš-eš | mi-yad |
| | Sima | from | reading-EZ | this book | good-3SG.CL | CONT-come.3SG |
| | ‘Sima likes reading this book.’ | | | | | |
| | | | | | | |
| c. | sima | æz | xundæn-e | ketab-e æli | xoš-eš | mi-yad |
| | Sima | from | reading-EZ | book-EZ Ali | good-3SG.CL | CONT-come.3SG |
| | ‘Sima likes reading Ali’s book.’ | | | | | |

In example (27), the complement to the long infinitive, *xundæn*, can be a full DP, as shown in (27)b and (27)c.¹⁴¹ Example (27)a, which appears to contain a bare noun (as argued by Ghomeshi), will be discussed at the end of this section. Contrast the data in

¹⁴⁰ In fact, Cowper (1992) has argued that the corresponding English constructions are nominal, too.

¹⁴¹ Note that the ezafe vowel, EZ, is arguably not part of the syntactic structure. See Ghomeshi (1997a) for a detailed discussion of the ezafe vowel in the syntax of Persian nominal constructions.

(27) with the sentences in (28). When the object is preverbal, only a bare noun is possible.

(28) *Long Infinitives with Pre-Verbal Complements*

- | | | | | | | |
|----|------------------------------------|------|--------------------|---------|-------------|---------------|
| a. | sima | æz | ketab | xundæn | xoš-eš | mi-yad |
| | Sima | from | book | reading | good-3SG.CL | CONT-come.3SG |
| | 'Sima likes reading books.' | | | | | |
| b. | *sima | æz | in ketab | xundæn | xoš-eš | mi-yad |
| | Sima | from | this book | reading | good-3SG.CL | CONT-come.3SG |
| | ('Sima likes reading this book.') | | | | | |
| c. | *sima | æz | ketab-e æli | xundæn | xoš-eš | mi-yad |
| | Sima | from | book-EZ Ali | reading | good-3SG.CL | CONT-come.3SG |
| | ('Sima likes reading Ali's book.') | | | | | |

While post-verbal object nominals in long infinitives may be either bare nominals or full DPs, the pre-verbal objects must be bare. The structures for (27)b and (28)a are given in (29)a and (29)b, respectively.

(29) *Structures for Persian Long Infinitives*

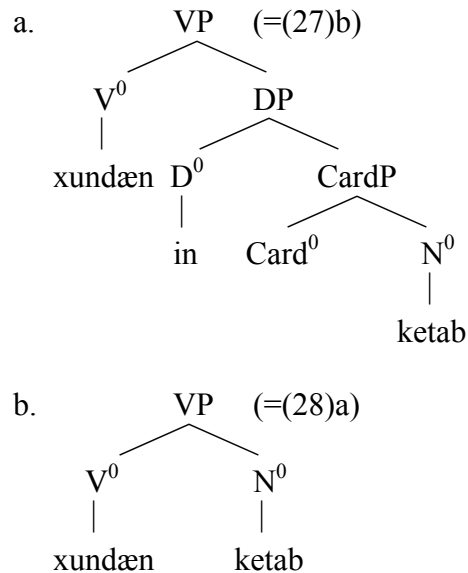

The structure in (29)a obeys the LCA, and no movement is triggered.¹⁴² The structure in (29)b, however, does violate the LCA and the noun must move to the specifier of the VP as shown in (30).

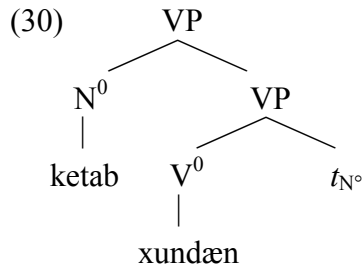

Example (27)a is still unexplained under the assumption that it is a bare noun as Ghomeshi (2003) argues. Native speakers report almost no difference in meaning between (27)a and (28)a. The only difference they report has to do with register. Whereas the pre-verbal bare noun is more natural in spoken conversation, the post-verbal noun is more formal and is more characteristic of the written form of the language. Dealing with optionality has always been difficult within a minimalist framework. One could posit a phonologically null [formal/written register] feature heading a functional projection above NP, which would stop Compl-to-spec movement, allowing the object nominal to remain in its Merge position, but this solution seems somewhat *ad hoc*. Ultimately, this question bears significantly on the proposal for identifying empty categories in chapter 2 – namely, that empty categories must have semantic content. If a null head is posited that has the effect of stopping Compl-to-spec movement, then there must be some semantic difference between the two forms with and without this head. This is precisely the situation here, where the only difference appears to be register. I leave this problem for

¹⁴² I assume that the ezafe vowel is inserted phonologically (Ghomeshi, 1997b). See also footnote 141.

future research, noting that it is part of a much larger problem within recent generative linguistics – specifically, the problem of optionality and register variation.¹⁴³

Leaving aside the question of optionality, the Persian noun incorporation data presented here are consistent with the Dynamic Antisymmetric approach to Bare Phrase Structure proposed here. Namely, when a verb merges with a bare noun, the noun must raise to SpecVP so as to satisfy the LCA.

4.4. Tamil Noun Incorporation and Coordination

Tamil is an SOV language that has been claimed to have noun incorporation (Steever, 1979). In this section, I look briefly at noun incorporation in Tamil and examine a structure that contains conjoined incorporated nominals. This structure will be shown to follow naturally from the proposal set forth here.

Since Tamil is SOV, noun incorporation is not immediately obvious as it causes no change in word order. However, incorporated nominals can be distinguished from unincorporated ones on the basis of case marking. The examples in (31) show a sentence

¹⁴³ Note, for example, preposition stranding in English. In standard colloquial English, preposition stranding is accounted by the need to raise the [*wh*] DP to SpecCP.

- i. Which table did you put the book on? (colloquial English)
- ii. On which table did you put the book? (formal/written English)

The lack of preposition stranding in Romance can be attributed to a morphological property of prepositions in Romance to cliticize to the right, thus, then entire PP must pied-pipe upon raising to SpecCP.

- iii. *(sur) quelle table as-tu mis le livre (*sur)?
(on) which table have-you put the book (on)
Which table did you put the book on?

Formal English, then, is somewhat problematic. Under the assumption that the syntax pied pipes as little as possible, PP pied-piping should never be possible, unless we can show that there is some ban in English against sentence-final prepositions. Of course, sentence-final prepositions are permitted in English, even in formal varieties of English that do not otherwise permit preposition stranding.

- iv. Yesterday, I slept in.
- v. My bed was slept in.

with a full DP object and a sentence with an incorporated nominal. Note that although Steever glosses the incorporated nominal as having nominative Case, he points out that nominative is phonologically unmarked. It might therefore be that the incorporated noun has no case at all.¹⁴⁴

(31) *Tamil Sentences*

- a. naan paṇatt-e eḍuttu-kiṭṭēen [Schiffman (1999: 97, ex (76))]
 I.nom money-ACC take.BEN.PST.PNG
 ‘I took the money for myself.’
- b. avan talai nimirntān [Steever, 1979]
 he.NOM head.(NOM) straighten.PST.3MSG
 ‘He straightened his head.’

Incorporated nouns in Tamil exhibit many of the core properties of incorporated nouns in other languages. For example, the incorporated noun cannot appear with adjectives or determiners. Tamil does differ in one important way from other languages, in that in Tamil it is possible for conjoined bare nouns to be incorporated, as in (32).

- (32) avan penṇum vīṭum pārkkap pōkirān [Steever, 1979]
 he.NOM girl.NOM.AND house.NOM.AND see.INF go.PRS.3MS
 ‘He is going to look for a bride and a house.’

It is this particular structure which we will focus on here. First, let us establish some basic assumptions about coordinate structures, and then turn to a discussion of the Tamil data.

I adopt Progovac’s (1997) treatment of coordination, with some modifications to make it compatible with Dynamic Antisymmetry. I adopt the structure given in (33). Each conjunct is the complement of a conjunction head, with which it forms a

¹⁴⁴ The presence of two “nominative” DPs is the source of an earlier claim that Tamil violates the putative universal that sentences cannot have more than one subject. Steever argues that these sentences do not have two subjects, but rather that the nominal closer to the verb is actually incorporated and does not bear true nominative Case.

conjunction phrase (ConjP). The two ConjPs are arguments of an empty head that is of the same type as the conjuncts.¹⁴⁵

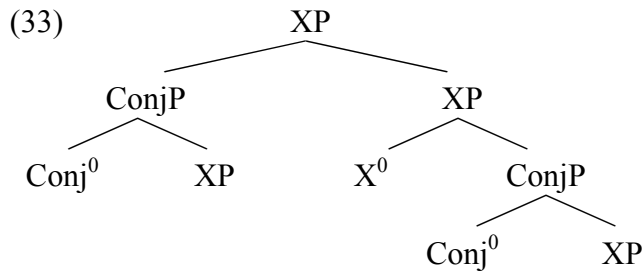

Example (32) is derived as follows. Each conjunct is independently formed by merging a conjunction with a bare noun, creating an instance of symmetric c-command. The bare noun in each case raises to SpecConjP so as to satisfy the LCA. The two ConjPs then merge with an empty N^0 as in (33). The resulting NP then merges with the verb, forming the structure in (34).

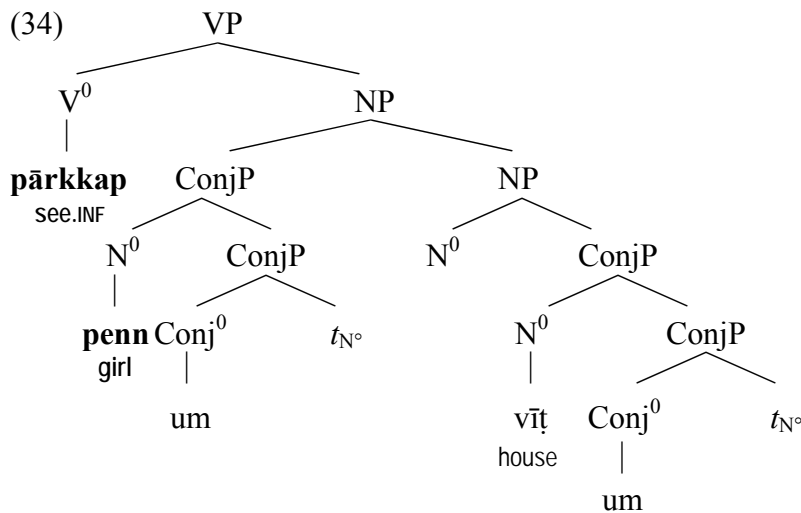

In this structure, however, the verb and the noun of the first conjunct, shown in boldface in (34), are in a symmetric c-command relation. This is resolved by raising the conjoined NP complex to SpecVP as shown in (35).

¹⁴⁵ This difference between this approach and Progovac's original approach is that Progovac right-adjoined each ConjP to an empty category of the same type as the conjuncts.

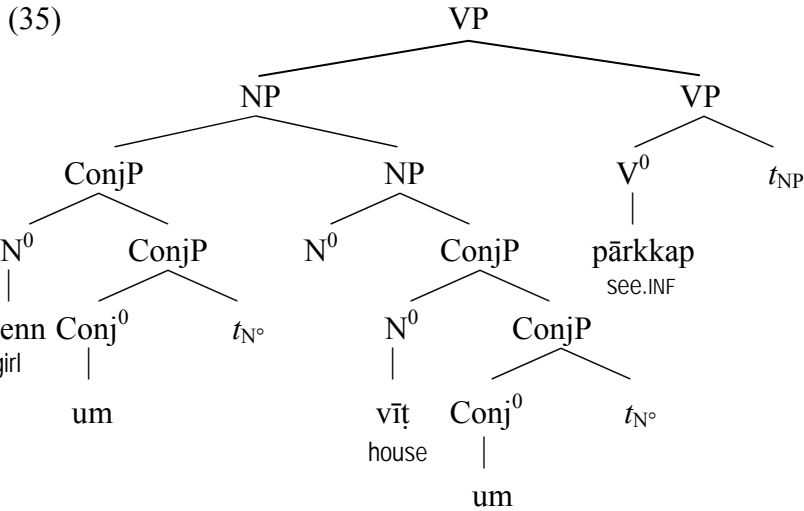

Noun incorporation in Tamil can be understood in terms of the overall analysis proposal here. Specifically, compl-to-spec roll-up is triggered by symmetric c-command, first between the conjunction and the bare noun, and subsequently between the first conjunct and the verb. An obvious question that arises from this discussion is why incorporation of conjoined nominals is allowed in Tamil but in almost no other language that allows noun incorporation. I leave this section with the following tentative suggestion. The conjunction in Tamil is post-nominal suggesting the noun raises to SpecConjP as shown above. In languages with pre-nominal conjunctions, no symmetric c-command configuration arises between the verb and the first conjunct to trigger raising, thus noun incorporation would fail for conjoined nominals in such a language. This is shown in (36).

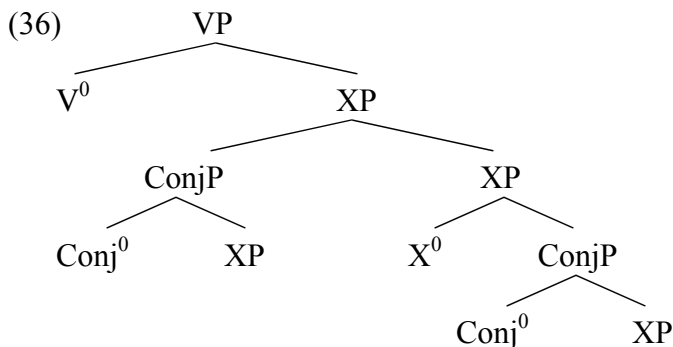

In (36), the verb asymmetrically c-commands the first Conj⁰, so no movement needs to take place.¹⁴⁶

4.5. Conclusion

This chapter has looked briefly at noun+verb compounding in English, German, Persian and Tamil. Preverbal bare nouns in English gerunds were shown to be unspecified for number and the count/mass distinction, which is taken to be evidence for the lack of a NumP in these constructions. The postverbal nominals in English gerunds were shown to include higher functional projections in the DP domain. In German progressive *beim* constructions, either the preverbal nouns are bare and are unspecified for number and the count/mass distinction, or they are marked as plural, but are still non-referential. This construction does not allow post-verbal nominals. In Persian, post-verbal nominals are full DPs and pre-verbal nominals are bare N⁰s. Post-verbal bare nominals are permitted in a formal or written register only. Finally, in Tamil, noun incorporation is

¹⁴⁶ English does have some examples of conjoined incorporated nouns such as *coin-and-stamp-collecting*. In this case, it would appear we have the following structure:

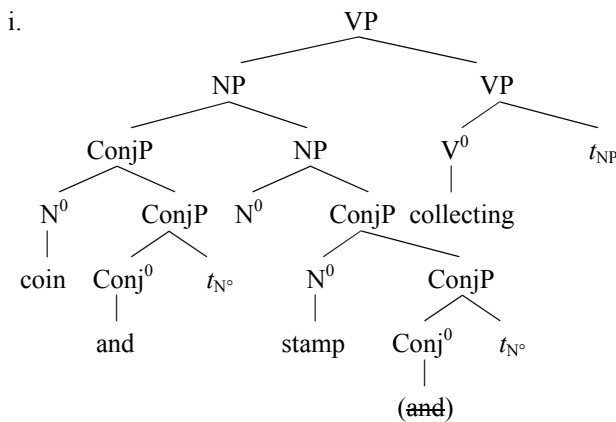

In this structure, *collecting* and *coin* c-command each other, triggering the NP to raise to SpecVP. Still unexplained here (and in coordinating constructions in general) is the choice of which Conj⁰ to pronounce. In the structure given here, the higher conjunction is pronounced at PF (as indicated by the strikethrough of the lower conjunction).

triggered by the need to satisfy the LCA; however, we also saw that conjoined nominals can be incorporated by the same mechanism argued for here. In all cases, incorporation is triggered by the need to satisfy the LCA in accordance with the Dynamic Antisymmetric approach to Bare Phrase Structure proposed in Chapter 2. In the next chapter, I look at a phenomenon called *pseudo noun incorporation* (Massam, 2001) in which the incorporated nominal appears after the verb.

5. Pseudo Noun Incorporation

So far, all instances of noun incorporation or N+V compounding we have dealt with have the noun preceding the verb. The following examples illustrate the cases so far, where the noun in **boldface** and the verb in *italics* to highlight their relative placement.

- (1) waʔkneskwahni:nú [Oneida]
 waʔ- k- neskwi- a- hninu- ‘:
 FACT- 1.SG.NOM- animal- JOIN- buy- PUNC
 ‘I bought an animal.’
- (2) John enjoys **elk-hunting**. [English]
- (3) Johannes ist beim **Mäntel-kaufen**. [German]
 Johannes is at.the **coat.PL-buying**
 ‘Johannes is busy buying coats.’
- (4) sima æz **ketab** xundæn xoš-eš mi-yad [Persian]
 sima from **book** reading good-3SG.CL CONT-come.3
 ‘Sima likes reading books.’

In this section, we investigate a type of noun incorporation that has the surface order verb-noun. The data discussed here come from Niuean, a Polynesian language of the Austronesian family, and are primarily taken from Massam’s (2001) discussion of the phenomenon for which she coined the term *pseudo noun incorporation*. I also discuss data from Māori and Tongan, both of which are also Polynesian.

Following Massam (2001), I argue that the crucial difference between the type of compounding discussed in this chapter and the type discussed in the previous two chapters is that, in Niuean, the verb selects a nominal category much higher than a bare noun. We will see that in cases of pseudo noun incorporation, a phonologically null head appears between the verb and the nominal head, putting a stop to Compl-to-spec roll-up, and thus preventing the nominal complex from raising to SpecVP.

5.1. Polynesian Pseudo Noun Incorporation

Massam (2001) refers to this type of noun incorporation as *pseudo noun incorporation* for reasons that will become clear directly. Consider the data in (5). Again, the noun is in **boldface** and the verb is in *italics* in the structures where incorporation has taken place.

(5) *Pseudo Noun Incorporation in Polynesian*

Niuean

- a. Ko e *fanogonogo* **lologo** a lautolu [Massam, 2001, ex. (18b)]
 PRES *listen* **song** ABS they
 ‘They were listening to songs.’
- b. Ko e fanogonogo a lautolu ke he tau lologo [*ibid.* ex. (18a)]
 PRES listen ABS they to PL song
 ‘They were listening to songs.’
- c. Ne *inu* **kofe kono** a Mele [*ibid.* ex. (6a)]
 PST *drink* **coffee bitter** ABS Mele
 ‘Mary drank bitter coffee.’
- d. ...ke *kumi* **motu ke nonofo ai.** [*ibid.* ex. (7d)]
 ...SBJV *seek* **island SUBJ settle there**
 ‘...to seek an island where they could settle.’

Māori

- e. Nā reira i tahuri ai te wahine rā ki te
 therefore TNS turn OBL.CL the woman that INF

kimi **huarahi** e *ea* ai **ōna wawata.**
find way TNS *be.satisfied* OBL.CL **her.PL desire**
 ‘Therefore the woman set about finding a way by which she could realize her goals.’
 [Chung & Ladusaw (2004)¹⁴⁷, p. 139, ex. (14a)]
- f. I *moe* **tāne, wāhine atu** ki reira [*ibid.*¹⁴⁸, p. 138, ex. (12a)]
 TNS *sleep* **man, woman away** at there
 ‘They married husbands and wives there.’

¹⁴⁷ citing Karetu (1974: 97)

¹⁴⁸ citing Jones & Biggs (1995)

Example (5)a shows a sentence with incorporation and (5)b shows a sentence in the canonical word order. The difference between pseudo noun incorporation and the noun incorporation discussed in the chapters 3 and 4 (aside from the linear order) is the amount of material that can be incorporated. Whereas in Oneida, English, German, Persian and Tamil, incorporation could move only a bare noun, or a bare noun augmented by plural morphology, pseudo noun incorporation can move much more material including adjectives as in (5)c, conjoined nouns as in (5)f, subjunctive relatives as in (5)d, and indicative relative clauses (Māori only) as in (5)e.¹⁴⁹

5.1.1. *The Structure of Niuean Nominals*

I adopt the following structure of Niuean nominals (Kahnemuyipour and Massam, 2003, to appear; Massam, 2000a, pc):

¹⁴⁹ There are two kinds of pseudo noun incorporation in Niuean. While it is true that in general incorporation, indicative relatives are impossible, they are possible in *fai*-incorporation structures. *Fai* is a verb which roughly means “to have”, thus, *fai*-incorporation structures indicate possession, thus asserting the existence of the object in question.

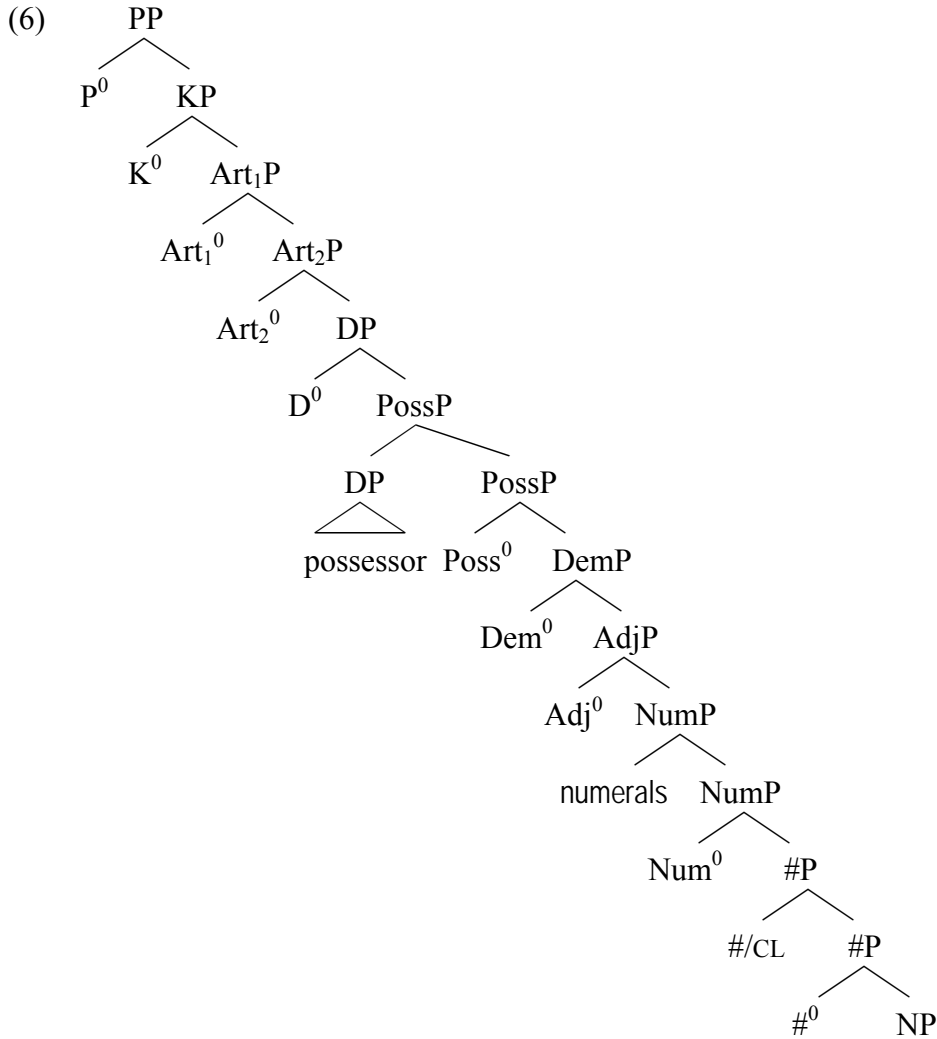

The higher article phrase, Art₁P, encodes the proper/common distinction and the lower article phrase, Art₂P, encodes specificity and number. The AdjP is iterable, and hosts adjectives in its head. NumP is optional, taking numerals in its specifier and the particle *e* in its head. The #P encodes plural number and classifier morphology. Massam and Kahnemuyipour (to appear) propose that this number and classifier morpheme appears in Spec#P rather than in the head. Furthermore, they suggest that the plural feature encoded on #⁰ is checked against the number feature of Art₂P.

The surface structure of nominals follows the following patterns. There is variation in the order of numerals and possessors, which is shown below.

(7) *Niuean DP Patterns*

- a. Case+P/C > # > N > Adj's > Dem
- b. Case+P/C > **Poss a** > # > N > Adj's > Dem
- c. Case+P/C > # > N > Adj's > Dem > **Poss**
- d. Case+P/C > **Num e** > # > N > Adj's > Dem
- e. Case+P/C > # > N > Adj's > Dem > **Num**

Massam and Kahnemuyipour argue for a Compl-to-spec roll-up analysis to derive the surface word order. I show here that their analysis is compatible with the proposal here that movement is driven by the need to satisfy the LCA. Consider the example in (8), which has the structure in (9). Adj_cP is used for the colour AdjP and Adj_qP for the quality AdjP.

- (8) e tau manu jula fulufuluola e: [M and K, ex. (1)a]
ABS.C PL bird red beautiful DEM
'those beautiful, red birds'

(9)

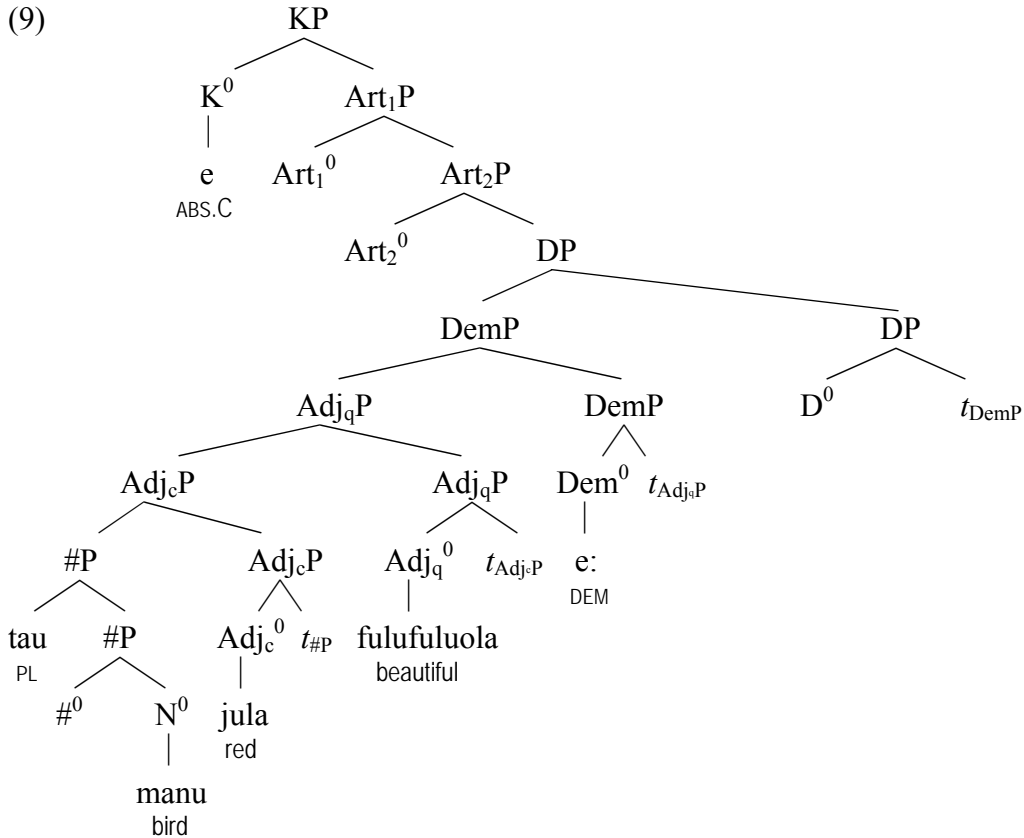

The derivation of this nominal is as follows. The phonologically null $\#^0$ merges with the noun, then the plural marker, a head, merges into Spec#P. The #P thus formed merges with the adjective *jula* ('red'). At this point, the adjective and the plural marker are in a symmetric c-command relation, in violation of the LCA. Symmetric c-command is eliminated by raising #P to SpecAdj_cP. The same problem arises when the adjective *fulufulu* ('beautiful') is merged with the Adj_cP, and the Adj_cP therefore raises to SpecAdj_qP. The demonstrative then merges with the Adj_qP thus formed, again creating a situation of symmetric c-command between the demonstrative and the plural marker. The AdjP thus raises to SpecDemP, which derives the correct order. What is interesting to note here is that I have not deviated from Kahnemuyipour and Massam's derivation at all. Their analysis follows directly from a Dynamic Antisymmetry view of Bare Phrase Structure as proposed in chapter 2.

In the next section, I look at examples of pseudo noun incorporation in Niuean.

5.1.2. *Pseudo Noun Incorporation*

In her discussion of pseudo noun incorporation, Massam (2001) observes that incorporated nominals in Niuean can include adjectives, subjunctive relatives, and demonstratives, but not case markers, plural markers, indicative relatives (except in *fai*-incorporation constructions – see fn. 149), or possessors. Thus, it appears that the direct object in such a construction may consist maximally of a DP. Massam suggests that the lack of plural morphology (in #P) is due to the absence of an Art_2^0 , the head against which the plural morpheme checks its plurality feature. Likewise, I assume that demonstratives and possessors are ruled out in these constructions, as these elements appear only in definite or specific nominals. Since definiteness and specificity are encoded on Art_1^0 , demonstratives and possessors are not licit in incorporated constructions, since the necessary feature is absent.

Unlike incorporated nominals in the other languages discussed, incorporated nominals in Niuean, at least, can be referential, even though this property is not morphologically marked.¹⁵⁰ This is illustrated in (10) (Massam, 2001; p. 159, example (6d)). In the following example, the incorporated noun is subsequently referred to.

¹⁵⁰ Note that only *fai*-incorporation constructions can take a referential incorporated nominal. See also fn. 149. I suggest pending further research that *fai* can select [+referential] nominals for pseudo noun incorporation while other verbs can select only [-referential] nominals for this process.

(10) Ne manatu e Mataginifale ko e mena *fai*
 PST think ABS Mataginifale PRED ABS thing *have*

mata-fohi **haku** **hiapo** a ia ne
blade-scraper **scratch** **tapa-plant** ABS she PST

huhulu he malo felevehi...
 shove in waist- cloth...

‘Mataginifale remembered that she had the blade of the tapa plant scraper
 which she had twisted in her waist cloth...’

Thus, DP is the highest possible projection found in pseudo noun incorporation constructions.¹⁵¹ Higher functional elements are never found in these constructions. Since there is no KP in a pseudo incorporated noun phrase, we assume that it does not raise to a Case checking position.¹⁵² Also, at least DP is necessary, since all elements lower than DP can be found in these constructions, including specification for referentiality as in (10) above.

Consider the derivation of (5)c repeated here.

(11) Ne **inu** **kofe kono** a Mele
 PST **drink** **coffee bitter** ABS Mele
 ‘Mary drank bitter coffee.’

The nominal *kofe kono* (‘bitter coffee’) by our hypothesis contains only a DP and, thus, does not raise to a Case position. According to Massam, it remains *in situ*. The structure of the VP, then is as follows.

¹⁵¹ Perhaps DP is not the best label for this projection, since referentiality, not determination is the feature at stake. I tacitly assume there that the left periphery of the noun phrase is split into a number of projections, each encoding various aspects of nominals such as specificity, determination, referentiality, etc. I leave this question for future research.

¹⁵² The tacit assumption here is that K^0 has an uninterpretable Case feature, thus only KPs need to raise to a position in the clause to check Case. Recall that Massam derives VSO word order by remnant movement of the VP to an EPP position in the IP domain, thus requiring overt movement of the object KP to a higher position.

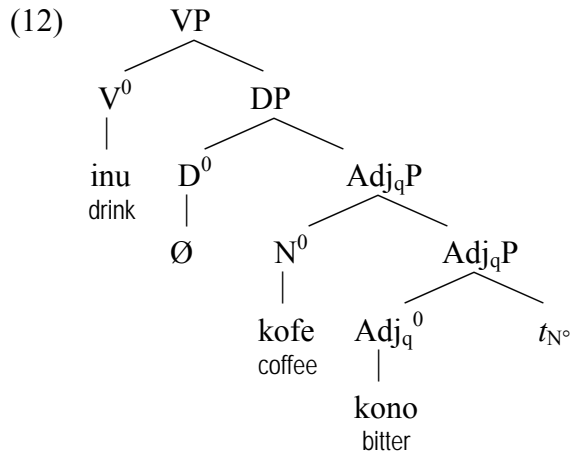

Recall that there is no #P in pseudo noun incorporation structures in Niuean since it is assumed that #⁰ must check its feature against a higher Art₂⁰. Since Art₂⁰ is absent, there is no #P in (12). Recall that the highest AdjP had to raise above DemP in (9) to eliminate the symmetric c-command between Dem⁰ and SpecAdjP. Since demonstratives are absent in pseudo noun incorporation, the Adj_qP is not required to raise to SpecDP. The resulting structure, then, does not require any further movement. Recall that Massam has argued that Niuean is a VP-fronting language. Thus, when the VP raises to the clause-initial position, it carries the DP along with it, resulting in the pseudo noun incorporation construction.

In this section, we have seen how the structure of Niuean nominal phrases gives rise to pseudo noun incorporation constructions within the Dynamic Antisymmetric framework proposed here. Pseudo noun incorporation arises by virtue of the lack of symmetric c-command between the verb and the nominal element that is its complement. As a result, the nominal complement does not raise to SpecVP and surfaces to the right of the verb. In the case of Niuean, the entire VP (with its pseudo incorporated noun) raises to the left periphery of the clause.

6. Conclusion

6.1. Summary

The goals of the discussion in this dissertation were both empirical and theoretical. First, the proposal put forth here is intended to capture the cross-linguistic generalization that noun incorporation constructions and constructions with full DP objects have different word orders. Specifically, incorporated nominals are typically preverbal. Data was shown from Oneida, English, German, Persian and Tamil which show this property. Pseudo noun incorporation constructions in Niuean, on the other hand, have postverbal nominals. Following Massam's approach, pseudo incorporated nominals remain in the complement to VP because there is no need for raising to take place in these constructions.

From a theoretical perspective, this dissertation has explored the possibilities in unifying two recent proposals on phrase structure – namely, Antisymmetry and Bare Phrase Structure. A core problem in bringing these two proposals together concerns the initial merger of two heads (the Initial Merger Problem). Whereas previous approaches tried to obviate this problem, I take the generalization above, that incorporated nouns, which are typically bare, are preverbal, to suggest a Dynamic Antisymmetric approach to noun incorporation, following proposals by Moro (2000; 2004). Thus, when a verb merges with a bare noun, an instance of symmetric c-command is formed, and the noun must raise to SpecVP to satisfy the LCA. If another head with phonological content merges with this VP, that head and the noun in SpecVP will again be in a symmetric c-command configuration and will trigger the VP to raise to the specifier of the new head. This movement, which I call Compl-to-spec Roll-Up, will take place until a

phonologically null head is merged with the derivation, since such heads do not need to be ordered linearly.

The second major theoretical point addressed here is the recent claim that head-movement does not exist (see Chomsky, 2000; Fanselow, 2003; Harley, 2004; Kayne, 2003b; Koopman and Szabolcsi, 2000; Mahajan, 2003 for discussion on this topic). Under this assumption, it is impossible to maintain an approach along the lines suggested by Baker (1988) to noun incorporation since his analysis relies crucially on head-movement. A phrasal movement analysis of noun incorporation is pursued using data from the incorporation of verbal roots into the verbal predicate. Such verbal roots must appear with a nominalizer morpheme suggesting that something larger than a head is involved in noun incorporation in Oneida. In other words, noun incorporation can be pursued without resorting to head movement.

6.2. Conclusions and Implications

In this dissertation, I have examined the possibility of bringing Antisymmetry and the ban on head-movement in line with Bare Phrase Structure. In particular, I considered a version of Antisymmetry that allows points of symmetry in the derivation to be resolved by movement. This is the position taken by Moro (2000, 2004), referred to as Dynamic Antisymmetry. In this version of Antisymmetry, the LCA holds only at the PF level of grammar, rather than at every stage of the derivation. I argued that, rather than being a weakened version of Antisymmetry, it is actually a more well-grounded take on the matter. The key points considered were that linearization is a PF constraint, so there is no need to be concerned with linear order throughout the syntactic derivation. Furthermore, Kayne's original reason for proposing that the LCA holds throughout the derivation was

that the LCA was responsible for the properties of X-bar Theory. The adoption of Bare Phrase Structure instead of X-bar Theory obviates the need to maintain the LCA throughout the derivation and places it in the phonological component, where it belongs.

As a point of departure, we considered initial merge of two heads, a structure which immediately violates the LCA. The symmetry was resolved by raising the complement to the specifier position of the head. It was shown that phrase structure continues to be built up by a series of instantiations of external merge followed immediately by internal merge, and that this method of building structure continues until the derivation merges a phonologically null head. At this point, the XP that is the complement to the phonologically null head does not need to raise any higher since whatever phonologically specified head merges above that can be linearized with the rest of the phrase structure. Again, the resolution of symmetry was the only trigger for movement considered here.

The conclusions reached about noun incorporation in Oneida suggest empirically that the XP-movement analysis of noun incorporation is on the right track. Specifically, the incorporation of verbal roots into a verb showed that something larger than a head must be incorporating since the verbal roots must be accompanied by a nominalizer. It was also shown that deviations from the productive nature of noun incorporation in Oneida can, for the most part, be explained by independent morphological factors, indirectly supporting the claim that noun incorporation is syntactic.

This study has implications for the nature of phrase structure in general. We have examined how noun incorporation works in other languages that are not typically thought of as exhibiting noun incorporation, and whether noun incorporation is a unitary

phenomenon with one structural explanation cross-linguistically. The phenomenon of pseudo noun incorporation in Niuean suggests that not all types of noun incorporation are the same. What remains unanswered is the restriction of noun incorporation in languages such as English to gerunds, while it is productive on verbs in Iroquoian. Clearly the approach pursued here in and of itself cannot answer this question.

This study makes strong claims about the nature of syntactic structure. The process of building structure in the Compl-to-spec Roll-Up manner described here is predicted to occur universally. Whether this claim receives empirical support from a wide range of languages or not will hopefully be the topic of future research. If this consequence of building phrase structure turns out to be falsified, it will force us to question the basic assumptions we have about Antisymmetry and Bare Phrase Structure. Recall also that the only trigger of movement discussed here was the resolution of symmetry. Although Moro (2000) claims that this might be the only trigger of movement in natural language, the traditional triggers of movement in a Minimalist approach, OCC/EPP and overt feature checking will have to be evaluated against this claim.

Although this thesis has dealt primarily with noun incorporation and related phenomena, this clearly is not the only empirical domain against which the theory of phrase structure and linearization proposed here can be tested. There are two situations to consider here. The first, which we have dealt with extensively throughout this thesis, is the merger of two heads. The second, which has crept into the discussion in minor ways is the merger of a head with a projection that has a head as its specifier. These are illustrated in (1)a and b, respectively.

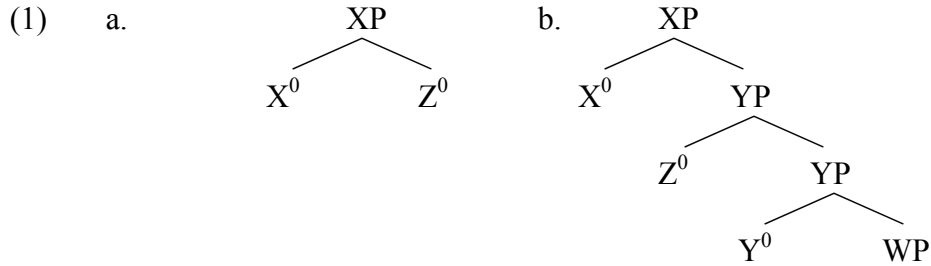

Other applications of the first type include nominal complements such as *professor of linguistics* and *linguistics professor*. Perhaps the noun, *professor*, takes a bare noun complement, *linguistics*, which must raise to SpecNP to satisfy the LCA.

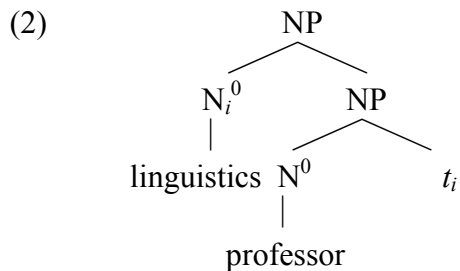

In the construction *professor of linguistics*, the preposition *of* assumedly takes a full DP complement. Since prepositions are Case assigners, *of* must take a DP complement, not a bare noun as a complement, since bare nouns cannot be assigned Case.

Other possibilities include a preposition taking a bare noun as a complement or a light lexical category taking another lexical category as a complement. Empirically, one can think of various alternations in word order that occur in language, such as the order between a noun and its determiner in Swedish.

- (3) a. hus- et
house- DET
'the house'
- b. et hus
DET house
'a house'

Another possible line of inquiry is the difference in order between finite and non-finite relative clauses in German and Turkish. The following German example shows that finite relative clauses are post-nominal while gerundive relative clauses are pronominal.

- (4) Die Kinder [die grünen Äpfeln gegessen haben]
 the children who green apples eat.PART have.3PL
 ‘the children who have eaten green apples’
- (5) Die [grünen Äpfeln essenden] Kinder
 the green apples eat.GER children
 ‘the children eating green apples’

As Kayne (1994) has described, relative clauses cannot be analyzed as right adjunction, since only left-adjunction is available to UG. Kayne develops an analysis of relative clauses in which the base position for the head noun is inside the relative clause. This idea has been pursued at great length in the Antisymmetry program (Bianchi, 1999). Another possibility to consider, though, is that the relative clause is in the specifier of a functional projection in the extended nominal projection and that in languages with post-nominal relative clauses, the noun raises above the XP hosting the relative clause (Kim, 1997). Under the theory proposed here, we would expect a point of symmetry between the noun in (4) and the relative clause, while there is no such point of symmetry in (5). This point of symmetry in (4) would then trigger the noun to raise above the relative clause.

Another avenue in which the effects of the theory of phrase structure proposed here can be tested is that of clitics. Clitics are arguably a bare head rather than a complex phrase. As such the possibility arises in which the clitic occupies the specifier of an argument position and is in a symmetric c-command relation with the immediately higher head (the configuration in (1)b). Clitics were briefly mentioned in Chapter 2, but a

complete analysis must wait for future research. Thus it remains to be seen how clitic phenomena relate to Bare Phrase Structure and Antisymmetry as described here.

Finally, one of the strengths of this thesis is that it explains noun incorporation without adding any new theoretical machinery to UG. Noun incorporation comes for free from the interaction of Bare Phrase Structure and Antisymmetry. In fact, both Bare Phrase Structure was accepted without any changes from its original conception, and Antisymmetry was altered only from those aspects which referred to X-Bar Theory. Thus, to the extent that the proposal developed here is successful, it represents a novel way in which to understand a wide variety of phenomena related to noun incorporation. Given that the current proposal adopts Bare Phrase Structure and Antisymmetry in virtually unaltered forms, the extent that the current proposal turns out not to be valid would then indicate that either or both of Bare Phrase Structure and Antisymmetry must undergo serious revision.

References

- Abbott, Clifford. 1984. "Two Feminine Genders in Oneida," in *Anthropological Linguistics* 26(2):125-137.
- . 2000. *Oneida*. Munich: Lincom Europa.
- Aboh, Enoch. 2004a. *The Morphosyntax of Complement-Head Sequences: Clause Structure and Word Order Patterns in Kwa*. Oxford: Oxford University Press.
- . 2004b. "Snowballing Movement and Generalized Pied-piping," in Anne Breitbarth and Henk Van Riemsdijk (eds.), *Triggers*, 15-48. The Hague: Mouton de Gruyter.
- Alboiu, Gabriela. 2000. The Features of Movement in Romanian, Department of Linguistics, University of Manitoba: Dissertation.
- Aldridge, Edith. 2003. "Remnant Movement in Tagalog Relative Clause Formation," in *Linguistic Inquiry* 34(4):631-640.
- Alexiadou, Artemis. 1997. *Adverb Placement: A Case Study in Antisymmetric Syntax*. Amsterdam: John Benjamins.
- Ambar, Manuela, and Jean-Yves Pollock. 2002. "Topic vs. Comment in Some Subject Inversion Sentences in French and Portuguese," in *Journal of Portuguese Linguistics* 1(1):119-138.
- Baauw, Sergio. 1998. "Subject-Verb Inversion in Spanish: Movement as Symmetry Breaker," in *Linguistics in the Netherlands* 15:1-12.
- Babyonyshev, Maria. 2002. "Deriving the Restrictions on Pronominal Complements of Nouns," in *Proceedings of Workshop on the Semantics/Syntax of Possessive Constructions*. University of Massachusetts.

- Baker, Mark. 1985. "The Mirror Principle and Morphosyntactic Explanation," in *Linguistic Inquiry* 16(3):373-416.
- . 1988. *Incorporation: A Theory of Grammatical Function Changing*. Chicago, IL: University of Chicago Press.
- . 1993. "Noun Incorporation and the Nature of Linguistic Representation," in William Foley (ed.) *The Role of Theory in Language Description*, 13-44. Berlin: Mouton de Gruyter.
- . 1996. *The Polysynthesis Parameter*. Oxford: Oxford University Press.
- Baker, Mark, Roberto Aranovich, and Lucía A. Golluscio. 2005. "Two types of syntactic noun incorporation: Noun incorporation in Mapudungun and its typological implications," in *Languague* 81(1).
- Baker, Mark, and Lisa Travis. 1997. "Mood as Verbal Definiteness in a "Tenseless" Language," in *Natural Language Semantics* 5:213-269.
- Baltin, Mark. 2001. "Movement to the Higher V is Remnant Movement," in *Linguistic Inquiry* 33(4):653-659.
- Barrie, Michael. 2003. "Pronominal agreement in Iroquoian nouns and verbs," in *Toronto Working Papers in Linguistics* 21:1-14.
- . in prep. ϕ -Features in the Onondaga Agreement Paradigm. ms., University of Toronto.
- Basilico, David. 1995. "Asymmetric Object Positions," in *Proceedings of Eastern States Conference on Linguistics*, 12: 1-12.
- Béjar, Susana. 2003. *Phi-Syntax: A Theory of Agreement*, Department of Linguistics, University of Toronto: Dissertation.

- Bianchi, Valentina. 1999. *Consequences of Antisymmetry: Headed relative clauses*.
 Berlin: Mouton de Gruyter.
- Bobaljik, Jonathan, and Jason Brown. 1997. "Interarborial Operations: Head movement and the extension requirement," in *Linguistic Inquiry* 28(2):345-356.
- Boeckx, Cedric. 1999a. Extractions. ms., University of Connecticut.
- . 1999b. Relativizing Spell-Out. ms., University of Connecticut.
- Boeckx, Cedric, and Sandra Stjepanovic. 2001. "Head-ing toward PF," in *Linguistic Inquiry* 32(2):345-355.
- Bošković, Željko. 1996. "Selection and the Categorical Status of Infinitival Complements," in *Natural Language & Linguistic Theory* 14(2):269-304.
- . 1997. *The Syntax of Nonfinite Complementation: An Economy Approach*. Cambridge, MA: MIT Press.
- . 2002. "Clitics as Nonbranching Elements and the Linear Correspondence Axiom," in *Linguistic Inquiry* 33(2):329-340.
- . 2005. "On the Locality of Left Branch Extraction and the Structure of NP," in *Studia Linguistica* 59(1):1-45.
- Bouchard, Denis. 2002. *Adjectives, Number and Interfaces: Why languages vary*.
 Amsterdam: Elsevier.
- Bowers, John. 2002. "Transitivity," in *Linguistic Inquiry* 33(2):183-224.
- Breitbarth, Anne, and Henk Van Riemsdijk eds. 2004. *Triggers*. The Hague: Mouton de Gruyter.
- Bresnan, Joan. 2001. *Lexical-Functional Syntax*. Oxford: Blackwell.

- Bruening, Benjamin. 2001. "QR Obeys Superiority: Frozen Scope and ACD," in *Linguistic Inquiry* 32(2):233-273.
- Burzio, Luigi. 1986. *Italian Syntax*. Dordrecht: Reidel.
- Caramazza, Alfonso, and Kevin Shapiro. 2004. "Language Categories in the Brain: Evidence from Aphasia," in Adriana Belletti (ed.) *Structures and Beyond: The Cartography of Syntactic Structures, Volume 3*, 15-38. Oxford: Oxford University Press.
- Chafe, Wallace. 1960a. "Seneca Morphology I: Introduction," in *International Journal of American Linguistics* 26(1):11-22.
- . 1960b. "Seneca Morphology II: Irreducible nouns and verbs; the modal verb," in *International Journal of American Linguistics* 26(2):123-130.
- . 1960c. "Seneca Morphology III: Expanded pronominal prefixes," in *International Journal of American Linguistics* 26(3):224-233.
- . 1960d. "Seneca Morphology IV: Expanded bases," in *International Journal of American Linguistics* 26(4):283-289.
- Cheng, Lisa Lai-Shen, and Rint Sybesma. 1999. "Bare and Not-So-Bare Nouns and the Structure of NP," in *Linguistic Inquiry* 30(4):509-542.
- Chomsky, Noam. 1957. *Syntactic Structures*. vol. 4: Janua Linguarum. The Hague: Mouton.
- . 1965. *Aspects of the Theory of Syntax*. Cambridge, MA: MIT Press.
- . 1970. "Remarks on Nominalization," in Roderick Jacobs and Peter Rosenbaum (eds.), *Readings in English Transformational Grammar*. Cambridge, MA: MIT Press.
- . 1981. *Lectures on Government and Binding*. Dordrecht: Foris.

- . 1993. "A Minimalist Program for Linguistic Theory," in Ken Hale and Samuel J. Keyser (eds.), *The View from Building 20: Essays in Linguistics in Honor of Sylvain Bromberger*, 1-52. Cambridge, MA: MIT Press.
- . 1994. *Bare Phrase Structure*. vol. 5: MIT Occasional Papers in Linguistics. Cambridge, MA: MIT Department of Linguistics and Philosophy, MITWPL.
- . 1995. *The Minimalist Program*. Cambridge, MA: MIT Press.
- . 2000. "Minimalist Inquiries: The Framework," in Roger Martin, D. Michaels and Juan Uriagereka (eds.), *Step by Step: Essays on Minimalist Syntax in Honor of Howard Lasnik*, 89-156. Cambridge, MA: MIT Press.
- . 2001a. Beyond Explanatory Adequacy. ms., MIT.
- . 2001b. "Derivation by Phase," in Michael Kenstowicz (ed.) *Ken Hale: A Life in Language*, 1-52. Cambridge, MA: MIT Press.
- . 2005a. On Phases. ms., MIT.
- Chomsky, Noam. 2005b. "Three factors in language design," in *Linguistic Inquiry* 36(1):1-22.
- Chung, Sandra, and William Ladusaw. 2004. *Restriction and Saturation: Linguistic Inquiry Monographs*. Cambridge, MA: MIT Press.
- Cinque, Guglielmo. 1999. *Adverbs and Functional Heads: A Cross-Linguistic Perspective*. New York, NY: Oxford University Press.
- Citko, Barbara. 2005. "On the Nature of Merge: External Merge, Internal Merge, and Parallel Merge," in *Linguistic Inquiry* 36(4):475-496.

- Clahsen, Harald, Gary Marcus, Susanne Bartke, and Richard Wiese. 1995. "Compounding and Inflection in German Child Language," in *Yearbook of Morphology*:115-142.
- Costa, João. 1997. "Positions for Subjects in European Portuguese," in Brian Agbayani and Sze-Wing Tang (eds.), *The Proceedings of the 15th West Coast Conference on Formal Linguistics*, 49-63. Stanford: CSLI.
- Cowper, Elizabeth. 1987. "Pied Piping, Feature Percolation and the Structure of the Noun Phrase," in *Canadian Journal of Linguistics* 32(4):321-338.
- . 1992. "Infinitival Complements of *Have*," in *Canadian Journal of Linguistics* 37(2):115-136.
- Cummings, Constance. 2002. XP (Remnant) Movement and Verb Serialization in Yoruba: Ph.D.Dissertation.
- Davis, Henry, and Lisa Matthewson. 1999. "On the Functional Determination of Lexical Categories," in *Revue Québécoise de Linguistique* 27(2):29-69.
- Déchaine, Rose-Marie, and Martina Wiltschko. 2002. "Decomposing Pronouns," in *Linguistic Inquiry* 33(3):409-442.
- Depraetere, Ilse. 1995. "On the Necessity of Distinguishing between (Un)boundedness and (A)telicity," in *Linguistics and Philosophy* 18(1):1-19.
- Di Sciullo, Anna Maria. 2005. *Asymmetry in Morphology*. Cambridge, MA: MIT Press.
- Di Sciullo, Anna Maria, and Edwin Williams. 1987. *On the Definition of Word*. Cambridge, MA: MIT Press.
- Dobrovie-Sorin, Carmen. 1994. *The Syntax of Romanian*. The Hague: Mouton de Gruyter.

- Don, Jan. 2004. "Categories in the Lexicon," in *Linguistics* 42(5):931-956.
- Dyck, Carrie. 1992. Case Assignment and Agreement in Cayuga. ms., University of Toronto.
- Epstein, Samuel, Erich Groat, Ruriko Kawashima, and Hisatsugo Kitahara. 1998. *A Derivational Approach to Syntactic Relations*. Oxford: Oxford University Press.
- Ernst, Thomas. 2003. "Adjuncts and Word Order Asymmetries," in Anna Maria di Sciullo (ed.) *Asymmetry in Grammar: Volume I: Syntax and semantics*, 187-208. Amsterdam: John Benjamins.
- Fanselow, Gisbert. 2003. "Münchhausen-Style Head Movement and the Analysis of Verb Second," in *UCLA Working Papers in Linguistics* 13:40-76.
- Fox, Danny, and David Pesetsky. 2005. "Cyclic Linearization of Syntactic Structure," in *Theoretical Linguistics* 31(1-2):1-46.
- Frank, Robert, and K. Vijay-Shanker. 2001. "Primitive C-Command," in *Syntax* 4(3):164-204.
- Froman, Frances, Alfred J. Keye, Lottie Keye, and Carrie Dyck. 2002. *English-Cayuga/Cayuga-English Dictionary*. Toronto: University of Toronto Press.
- Ghomeshi, Jila. 1997a. "Non-Projecting Nouns and the *Ezafe* Construction in Persian," in *Natural Language & Linguistic Theory* 15(4):729-788.
- . 1997b. "Topics in Persian VPs," in *Lingua* 102(2-3):133-167.
- . 2001. "Control and Thematic Agreement," in *Canadian Journal of Linguistics* 46(1/2):9-40.
- . 2003. "Plural Marking, Indefiniteness, and the Noun Phrase," in *Studia Linguistica* 57(2):47-74.

- Giorgi, Alessandra, and Giuseppe Longobardi. 1991. *The syntax of Noun Phrases*.
Cambridge: Cambridge University Press.
- Greenberg, Joseph. 1963. *Universals of Language*. Cambridge, MA: MIT Press.
- Guasti, Maria-Teresa, and Andrea Moro. 2001. "Romance causatives and dynamic antisymmetry: Essays Offered to Lorenzo Renzi," in Guglielmo Cinque and Giampaolo Salvi (eds.), *Current Studies in Italian Syntax*: Elsevier North Holland.
- Guimarães, Maximiliano. 2000. "In Defense of Vacuous Projections in Bare Phrase Structure," in *University of Maryland Working Papers in Linguistics* 9:90-115.
- Haegeman, Liliane. 2000. "Remnant Movement and OV Order," in Peter Svenonius (ed.) *The Derivation of VO and OV*, 69-96. Amsterdam: John Benjamins.
- . 2001. "Antisymmetry and Verb-Final Order in West Flemish," in *The Journal of Comparative Germanic Linguistics* 3(3):207-232.
- Hale, Ken. 2001. Navajo Verb Structure and Noun Incorporation. ms., MIT.
- Hale, Ken, and Samuel J. Keyser. 2003. *A Prolegomenon to a Theory of Argument Structure*. Cambridge, MA: MIT Press.
- Halle, Morris, and Alec Marantz. 1993. "Distributed Morphology and the Pieces of Inflection," in Kenneth Hale and Samuel J. Keyser (eds.), *The View from Building 20: Essays in Linguistic in Honor of Sylvain Bromberger*, 111-176. Cambridge, MA: MIT Press.
- Hallman, Peter. 2004. "Symmetry in Structure Building," in *Syntax* 7(1):79-100.

- Harley, Heidi. 2004. "Merge, conflation and head movement: The First Sister Principle revisited," in Keir Moulton and Matthew Wolf (eds.), *NELS 34*. Amherst, MA: GLSA.
- Huang, C.-T. James. 1982. *Logical Relations in Chinese and the Theory of Grammar*, Department of Linguistics and Philosophy, MIT: Ph.D. Dissertation.
- Jackendoff, Ray. 1977. *X-bar Syntax: A Study of Phrase Structure*. vol. 2: Linguistic Inquiry Monographs. Cambridge, MA: MIT Press.
- Jaeggli, Osvaldo. 1986. "Three Issues in the Theory of Clitics: Case, Doubled NPs, and Extraction," in Hagit Borer (ed.) *Syntax and Semantics: The Syntax of Pronominal Clitics*. Orlando, FL: Academic Press.
- Jelinek, Eloise. 1984. "Empty categories, case, and configurationality," in *Natural Language & Linguistic Theory* 2(1):39-76.
- Jiang-King, Ping. 1998. "Sonority Constraints on Tonal Patterns," in Kimary Shahin, Susan Blake and Eun-Sook Kim (eds.), *The Proceedings of the Seventeenth West Coast Conference on Formal Linguistics*, 332-346. Stanford, CA: Center for the Study of Language and Information.
- Johns, Alana. 2003. *Restricting Noun Incorporation*. ms., University of Toronto.
- Jones, Pei Te Hurinui, and Bruce Biggs. 1995. *Nga iwi o Tainui: The traditional history of the Tainui people*. Auckland, New Zealand: Auckland University Press.
- Julien, Marit. 2002. *Syntactic Heads and Word Formation*. Oxford: Oxford University Press.

- Kahnemuyipour, Arsalan. 2000. On the Derivationality of some Inflectional Affixes in Persian. Paper presented at Annual Meeting of the Linguistics Society of America, Chicago, IL.
- . 2001. "On *Wh*-Questions in Persian," in *Canadian Journal of Linguistics* 46(1/2):41-61.
- Kahnemuyipour, Arsalan, and Diane Massam. 2003. "Inversely Ordered DPs in Niuean," in *The Proceedings of the 2002 Annual Meeting of the Canadian Linguistics Association*, 156-166: Université du Québec.
- . to appear. "Patterns of Phrasal Movement," in Hans-Martin Gaertner, Paul Law and Joachim Sabel (eds.), *Clause Structure and Adjuncts in Austronesian Languages*: Mouton de Gruyter.
- Kandybowicz, Jason, and Mark C. Baker. 2003. "On Directionality and the Structure of the Verb Phrase: Evidence from Nupe," in *Syntax* 6(2):115-155.
- Karetu, T. S. 1974. *Te Reo Rangatira: A course in Māori for sixth and seventh forms*. Wellington, New Zealand: GP Publications.
- Kayne, Richard. 1989. "Null Subjects and Clitic Climbing," in Osvaldo Jaeggli and Ken Safir (eds.), *The Null Subject Parameter*, 239-261. Dordrecht: Reidel.
- . 1991. "Romance Clitics, Verb Movement, and PRO," in *Linguistic Inquiry* 22(4):647-686.
- . 1994. *The Antisymmetry of Syntax*. Cambridge, MA: MIT Press.
- . 2003a. "Antisymmetry and Japanese," in *English Linguistics* 20:1-40.

- . 2003b. "Antisymmetry, Adpositions and Remnant Movement," in *Proceedings of Workshop on Antisymmetry and Remnant Movement*. New York University, Oct 31 - Nov 1, 2003.
- . 2004a. "Prepositions as Probes," in Adriana Belletti (ed.) *Structures and Beyond: The cartography of syntactic structures, Volume 3*, 192-212. Oxford: Oxford University Press.
- . 2004b. "Some Notes on Comparative Syntax: With Special Reference to English and French," in Adriana Belletti (ed.) *Structures and Beyond: The cartography of syntactic structures, Volume 3*, 277-333. Oxford: Oxford University Press.
- Kim, Young-Kook. 1997. "Agreement phrases in DP," in *UCL Working Papers in Linguistics* 9:281-302.
- Kiparsky, Paul. 1982. "Lexical Morphology and Phonology," in Ik-Hwan Lee (ed.) *Linguistics in the Morning Calm*, 3-91. Seoul: Hanshin.
- Kishimoto, Hideki. 2000. "Indefinite Pronouns and Overt N-Raising," in *Linguistic Inquiry* 31(3):557-566.
- Koizumi, Masatoshi. 1995. *Phrase Structure in Minimalist Syntax*, Department of Linguistics and Philosophy, MIT: Ph.D. Dissertation.
- Koncar, Katarina. 2005. ms., University of Toronto.
- Koopman, Hilda, and Anna Szabolcsi. 2000. *Verbal Complexes*. Cambridge, MA: MIT Press.
- Kratzer, Angelika. 1995. "Stage-level and Individual-level Predicates," in Gregory N. Carlson and Francis Jeffrey Pelletier (eds.), *The Generic Book*, 125-175. Chicago, IL: University of Chicago Press.

- . 2004. "Telicity and the Meaning of Objective Case," in Jacqueline Guéron and Jacqueline Lecarme (eds.), *The Syntax of Time*, 389-424. Cambridge, MA: MIT Press.
- Larson, Richard. 1988. "On the Double Object Construction," in *Linguistic Inquiry* 19(3):335-391.
- . 1990. "Double Objects Revisited: Reply to Jackendoff," in *Linguistic Inquiry* 21(4):589-632.
- Lasnik, Howard. 1981. "Restricting the Theory of Transformations: A case study," in Norbert Hornstein and David W. Lightfoot (eds.), *Explanations in Linguistics*. London: Longmans.
- . 1995. "Last Resort and Attract F," in Gabriele Hardison, D. and R. Westmoreland (eds.), *Proceedings of The Sixth Annual Meeting of the Formal Linguistics Society of Mid-America*, 1. Bloomington, IN, Indiana University.
- Lebeaux, David. 1988. Language Acquisition and the Form of the Grammar, Department of Linguistics, University of Massachusetts: Ph.D. Dissertation.
- . 1991. "Relative Clauses, Licensing and the Nature of the Derivation," in Susan Rothstein (ed.) *Syntax and Semantics 25: Perspective on Phrase Structure: Heads and licensing*, 209-239. San Diego, CA: Academic Press.
- Lee, Felicia Ann. 2000. Antisymmetry and the Syntax of San Lucas Quiavini Zapotec: Ph.D. Dissertation.
- Legate, Julie. 2002. Warlpiri: Theoretical Implications, Department of Linguistics and Philosophy, MIT: Ph.D. Dissertation.
- . 2003. "Some Interface Properties of the Phase," in *Linguistic Inquiry* 34(3):506-516.

Li, Yafei. 2005. *X⁰: A Theory of the Morphology-Syntax Interface*. Cambridge, MA: MIT Press.

Li, Yen-hui Audrey. 1999. "Plurality in a Classifier Language," in *Journal of East Asian Linguistics* 8(1):75-99.

Lin, Vivian. 2000. "Determiner Sharing," in Roger Billerey and Brook Danielle Lillehaugen (eds.), *Proceedings of WCCFL 19*, 274-287. Somerville, MA: Cascadilla Press.

Lounsbury, Floyd Glenn. 1949. *Iroquoian Morphology*, Yale University: Ph.D. Dissertation.

---. 1953. *Oneida Verb Morphology*. New Haven, CT: Yale University.

Mahajan, Anoop. 2003. "Word Order and (Remnant) VP Movement," in Simin Karimi (ed.) *Word Order and Scrambling*, 217-237. Malden, MA: Blackwell Publishers.

Marantz, Alec. 1997. "No Escape from Syntax: Don't Try Morphological Analysis in the Privacy of Your Own Lexicon," in *University of Pennsylvania Working Papers in Linguistics* 4(2):201-225.

---. 2001. "Words," in *Proceedings of West Coast Conference on Formal Linguistics*. University of California at Santa Cruz.

Massam, Diane. 2000a. "Niuean Nominalization," in Marian Klammer (ed.) *Proceedings of AFLA 7*. Amsterdam: Vrije Universiteit.

---. 2000b. "VSO and VOS: Aspects of Niuean Word Order," in Andrew Carnie and Eithne Guilfoyle (eds.), *The Syntax of Verb Initial Languages*, 97-116. Oxford: Oxford University Press.

- . 2001. "Pseudo Noun Incorporation in Niuean," in *Natural Language and Linguistic Theory* 19(1):153-197.
- Matushansky, Ora. 2006. "Head Movement in Linguistic Theory," in *Linguistic Inquiry* 27(1).
- McGinnis, Martha. 2003. "Variation in the Phase Structure of Applicatives," in J. Rooryck and P. Pica (eds.), *Linguistic Variations Yearbook*. Amsterdam: John Benjamins Publishing Co.
- Michelson, Karin. 1991. "Possessor Stranding in Oneida," in *Linguistic Inquiry* 22(4):756-761.
- Michelson, Karin, and Mercy Doxtator. 2002. *Oneida-English/English-Oneida Dictionary*. Toronto, ON: University of Toronto Press.
- Mithun, Marianne. 1984. "The Evolution of Noun Incorporation," in *Language* 60(4):847-894.
- . 1986. "On the Nature of Noun Incorporation," in *Language* 62(1):32-37.
- Mithun, Marianne, and Greville G. Corbett. 1999. "The Effect of Noun Incorporation on Argument Structure," in Lunella Mereu (ed.) *Boundaries of Morphology and Syntax*, 49-71. Amsterdam: John Benjamins.
- Moro, Andrea. 1997. *The Raising of Predicates: Predicative noun phrases and the theory of clause structure*. Cambridge: Cambridge University Press.
- . 2000. *Dynamic Antisymmetry*. Cambridge, MA: MIT Press.
- . 2004. "Linear Compression as a Trigger for Movement," in Anne Breitbarth and Henk van Riemsdijk (eds.), *Triggers*, 387-430. Berlin/New York, NY: Mouton de Gruyter.

- Moulton, Keir. 2004. "External Arguments and Gerunds," in *Toronto Working Papers in Linguistics* 22.
- Muller, Gereon. 1996. "A Constraint on Remnant Movement," in *Natural Language & Linguistic Theory* 14(2):355-407.
- Müller, Gereon. 1997. "Extraposition as Remnant Movement," in Dorothee Deerman, David LeBlanc and Henk van Riemsdijk (eds.), *Rightward Movement*, 215-246. Amsterdam/Philadelphia: John Benjamins Publishing.
- . 2004. "Verb-Second as vP-First," in *Journal of Comparative Germanic Linguistics* 7(3):179-234.
- Nakajima, Takashi. 1999. *Word Order in the Minimalist Program: A Derivational Approach*, Department of Linguistics, Cornell University: Ph.D. Dissertation.
- Nunes, Jairo. 2004. *Linearization of Chains and Sideward Movement*. Cambridge, MA: MIT Press.
- Nunes, Jairo, and Juan Uriagereka. 2000. "Cyclicality and Extraction Domains," in *Syntax* 3(1):20-43.
- Oda, Kenji. 2003. "Irish as a VP Fronting Language," in *Proceedings of Canadian Linguistic Association 2002: Université de Montréal à Québec*.
- . 2005. "V1 and *wh*-questions: a typology," in Andrew Carnie, Heidi Harley and Sheila Ann Dooley (eds.), *Verb First: On the syntax of verb-initial languages*, 107-133. Amsterdam/Philadelphia, PA: John Benjamins.
- Ogawa, Yoshiki. 2001. *A Unified Theory of Verbal and Nominal Projections*. Oxford: Oxford University Press.

- Oishi, Masayuki. 2003. "When Linearity Meets Bare Phrase Structure," in *Current Issues in English Linguistics* 2:18-41.
- Partee, Barbara H., Alice ter Meulen, and Robert Wall. 1993. *Mathematical Methods in Linguistics*. Dordrecht: Kluwer.
- Pesetsky, David, and Esther Torrego. 2004. The Syntax of Valuation and the Interpretability of Features. ms., MIT; UMass, Boston.
- Pires, Acrisio. 2002. The Syntax of Gerunds and Infinitives: Subjects, Case and Control, University of Maryland: Ph.D. Dissertation.
- Progovac, Ljiljana. 1997. "Slavic and the structure for coordination," in Martina Lindseth and Steven Franks (eds.), *Proceedings of Formal Approaches to Slavic Linguistics, 1996*. Ann Arbor, MI, Michigan Slavic Publications.
- Pylkkänen, Liina. 2002. *Introducing Arguments*. Cambridge, MA: MIT Working Papers in Linguistics.
- Rackowski, Andrea, and Lisa Travis. 2000. "V-Initial Languages: X or XP Movement and Adverbial Placement," in Andrew Carnie and Eithne Guilfoyle (eds.), *The Syntax of Verb Initial Languages*, 117-142. Oxford: Oxford University Press.
- Reich, Peter. 2005. "POCs & Clichés & Oddball Constructions, Oh My!" in *Proceedings of LACUS Forum XXXI: Interconnections*, 301-316 The Linguistic Association of Canada and the United States.
- Reinhart, Tanya. 1976. The Syntactic Domain of Anaphora, Department of Linguistics and Philosophy, MIT: Ph. D. Dissertation.
- Rezac, Milan. 2004a. Elements of Cyclic Syntax: Agree and Merge, Department of Linguistics, University of Toronto: Ph.D. Dissertation.

- . 2004b. "The EPP in Breton: An Unvalued Categorical Feature," in Anne Breitbarth and Henk Van Riemsdijk (eds.), *Tiggers*, 451-492. Berlin, New York: Mouton de Gruyter.
- Richards, Norvin. 1998. "The Principle of Minimal Compliance," in *Linguistic Inquiry* 29(4):599-629.
- . 2001. "A Distinctness Condition on Linearization," in *Proceedings of West Coast Conference on Formal Linguistics*, 20, 470-483.
- Ritter, Elizabeth. 1992. "Cross-Linguistic Evidence for Number Phrase," in *Canadian Journal of Linguistics* 37(2):197-218.
- Ritter, Elizabeth, and Sara Rosen. 2005. "Agreement without A-Positions: Another Look at Algonquian," in *Linguistic Inquiry* 36(4):648-660.
- Rizzi, Luigi. 1997. "The Fine Structure of the Left Periphery," in Liliane Haegeman (ed.) *Elements of Grammar: A handbook in generative syntax*, 281-337. Dordrecht: Kluwer Academic Publishers.
- . 1999. On the Position of "Int(errogative)" in the Left Periphery of the Clause: Università di Siena.
- Roberge, Yves. 1990. *The Syntactic Recoverability of Null Arguments*. Montreal, PQ: McGill-Queen's University Press.
- Rosen, Sara. 1989. "Two Types of Noun Incorporation: A Lexical Analysis," in *Language* 65(2):294-317.
- Ross, John. 1967. Constraints on Variables in Syntax, Department of Linguistics and Philosophy, MIT: Ph.D. Dissertation.
- Rubin, Edward J. 2003. "Determining Pair-Merge," in *Linguistic Inquiry* 34(4):660-668.

- Ruhlen, Merritt. 1975. *A Guide to the Languages of the World*. ms., Language Universals Project, Stanford University.
- Russell, Kevin, and Charlotte Reinholtz. 1997. "Nonconfigurationality and the Syntax-Phonology Interface," in B. Agbayani and Sze-Wing Tang (eds.), *Proceedings of West Coast Conference on Formal Linguistics, 15*, 441-455. Stanford, CA, CSLI.
- Sadock, Jerrold. 1980. "Noun Incorporation in Greenlandic: A Case of Syntactic Word Formation," in *Language* 56(2):300-319.
- . 1985. "Autolexical Syntax: A Proposal for the Treatment of Noun Incorporation and Similar Phenomena," in *Natural Language & Linguistic Theory* 3(4):379-439.
- . 1986. "Some Notes on Noun Incorporation," in *Language* 62(1):19-31.
- Safir, Ken. 1999. "Vehicle Change and Reconstruction in A Chains," in *Linguistic Inquiry* 30(4):587-620.
- Sag, Ivan, and Thomas Wasow. 1999. *Syntactic Theory: A Formal Introduction*. Stanford: CSLI Publications.
- Schiffman, Harold F. 1999. *A Reference Grammar of Spoken Tamil*. Cambridge: Cambridge University Press.
- Speas, Margaret. 1990. *Phrase Structure in Natural Language*. Dordrecht: Kluwer Academic Publishers.
- Sportiche, Dominique. 1996. A-Reconstruction and Constituent Structure. Paper presented at, University of California, Irving.
- . 1998. Reconstruction and Constituent Structure. Paper presented at, MIT.

- Steever, Sanford B. 1979. Noun Incorporation in Tamil, or What's a Noun Like You Doing in a Verb Like This? In *Papers from the Regional Meetings*, 279-290. Chicago, IL: Chicago Linguistic Society.
- Stepanov, Arthur. 2001a. Cyclic Domains in Syntactic Theory, Department of Linguistics, University of Connecticut: Ph.D. Dissertation.
- . 2001b. "The End of CED?" in *Proceedings of the West Coast Conference on Formal Linguistics* 20:524-537.
- Stowell, Tim. 1981. Origins of Phrase Structure, Department of Linguistics and Philosophy, MIT: Ph.D. Dissertation.
- Strozer, Judith. 1976. Clitics in Spanish, Department of Linguistics, University of California: Ph. D. Dissertation.
- Szabolcsi, Anna. 1981. "The Possessive Construction in Hungarian: A Configurational Category in a Non-Configurational Language," in *Acta Linguistica Academiae Scientiarum Hungaricae* 31(1-4):261-289.
- . 1983. "The Possessor that Ran Away from Home," in *The Linguistic Review* 3(1):89-102.
- . 1992. "Subordination, Articles and Complementizers," in Istvan Kenesei and C. Pléh (eds.), *Approaches to Hungarian. Vol. 4: The Structure of Hungarian*, 123-137. Jate: Szeged.
- Takano, Yuji. 2000. "Illicit Remnant Movement: An Argument for Feature-Driven Movement," in *Linguistic Inquiry* 31(1):141-156.
- Tanaka, Schichiro. 1997. "VP and the Split AgroP Hypothesis," in *Linguistic Analysis* 27(3-4):269-368.

- Toyoshima, Takashi. 2000. Head-To-Spec Movement and Dynamic Economy, Cornell University: Ph.D. Dissertation.
- Travis, Lisa. 1989. "Parameters of Phrase Structure," in Mark Baltin and Anthony Kroch (eds.), *Alternative Conceptions of Phrase Structure*, 263-279. Chicago, IL: Chicago University Press.
- . 1991. Inner aspect and the structure of VP. Paper presented at NELS 22, University of Delaware.
- Uriagereka, Juan. 1995a. "Aspects of the Syntax of Clitic Placement in Western Romance," in *Linguistic Inquiry* 26(1):79-123.
- . 1995b. "An F Position in Western Romance," in Kiss É. Katalin (ed.) *Discourse Configurational Languages*, 153-175. Oxford: Oxford University Press.
- . 1999. "Multiple Spell Out," in Samuel Epstein and Norbert Hornstein (eds.), *Working Minimalism*, 251-282. Cambridge, MA: MIT Press.
- Wang, Lianqing. 1994. Origin and development of classifiers in Chinese, Ohio State University: Ph.D. Dissertation.
- Williams, Marianne Mithun. 1976. *A Grammar of Tuscarora*. New York, NY: Garland Press.
- Wiltschko, Martina. 2002. "Agreement morphemes as determiner: Reanalyzing the polysynthetic properties of Mohawk," in *University of British Columbia Working Papers in Linguistics* 10:169-182.
- . 2004. Expletive categorial information: A case study of Number marking in Halkomelem Salish. Paper presented at NELS 35, Oct 22-24, University of Connecticut.

- Wojdak, Rachel. 2005. *The Linearization of Affixes: Evidence from Nuu-Chah-Nulth*, Department of Linguistics, University of British Columbia: Ph. D. dissertation.
- Woodbury, Hanni. 2003. *Onondaga-English/English-Onondaga Dictionary*. Toronto, ON: University of Toronto Press.
- Wurmbrand, Susi. 1998. *Infinitives*, MIT: Ph.D Dissertation.
- Zwart, C. Jan-Wouter. 1997. "The Germanic SOV languages and the Universal Base Hypothesis," in Liliane Haegeman (ed.) *The New Comparative Syntax*, 246-267. London/New York: Longman Linguistics Library.